

GE Energy Services
Digital Energy



Hydran* 201*i* System

Instruction Manual



NOTICE OF COPYRIGHT AND PROPRIETARY RIGHTS

© 2007-2011, General Electric Canada. All rights reserved. The contents of this manual and the information contained herein are the exclusive property of General Electric Canada, except as otherwise indicated. You may not disclose, reproduce, publish, license, post, transmit or distribute this manual, in whole or in part, without the prior written permission of General Electric Canada or except as permitted by written license agreement with General Electric Canada. General Electric Canada has made every reasonable attempt to ensure the completeness and accuracy of this manual. However, the information contained in this manual is subject to change without notice, and does not represent a commitment on the part of General Electric Canada. Any included or attached hardware schematics and technical descriptions, or software listings that disclose source code, are for information purposes only. Reproduction, in whole or in part, to create working hardware or software for other than General Electric Canada products is strictly prohibited, except as permitted by written license agreement with General Electric Canada.

TRADEMARK NOTICES

* Trademarks or registered trademarks of General Electric Company and/or General Electric Canada.

Microsoft and Windows are trademarks or registered trademarks of Microsoft Corporation in the United States and/or other countries.

All other brand and product names mentioned in this manual are trademarks or registered trademarks of their respective companies.

For information on other General Electric Canada products, please contact the Customer Service:

GE Energy Services
Digital Energy
179 Brunswick Blvd., Pointe-Claire QC H9R 5N2, Canada
Tel.: +1 514 694 3637, Fax: +1 514 694 9245
transformermonitoring@ge.com
www.ge.com/energy

Customer Service Center
(24 hours a day, 365 days a year):
Tel.: 800 361 3652 (United States and Canada), +1 403 214 4600 (worldwide)
ge4service@ge.com

SAFETY WARNINGS IN SIX LANGUAGES

[EN] (in English) WARNINGS:

- All procedures in this manual must be strictly adhered to.
- Any deviation from these could cause irreversible damages to the transformer being monitored and/or the Hydran 201i, and could lead to property damage, personal injury and/or death.
- Installation and maintenance of the Hydran 201i must be carried out by qualified personnel only.
- For a maximum distance of 15 m (50 ft) from the power source, use a 14-AWG (2.08 mm²) cable and a 15-A maximum overcurrent protection.

[FR] (in French) ATTENTION :

- Toutes les procédures dans ce manuel doivent être observées rigoureusement.
- Tout écart par rapport à celles-ci pourrait causer des dommages irréversibles au transformateur surveillé et/ou au Hydran 201i, et pourrait entraîner des dommages à la propriété, des blessures corporelles et/ou la mort.
- L'installation et l'entretien du Hydran 201i doivent être effectués par du personnel qualifié seulement.
- Pour une distance maximale de 15 m (50 pi) de la source d'alimentation, utiliser un câble de 14 AWG (2,08 mm²) et une protection maximale de 15 A contre les surintensités.

[ES] (in Spanish) ADVERTENCIA:

- Se debe cumplir estrictamente con todos los procedimientos señalados en este manual.
- Cualquier desviación al respecto puede causar daños irreparables al transformador que está bajo monitoreo y/o al Hydran 201i, asimismo puede ser causa de daños materiales, lesiones corporales y/o muerte.
- La instalación y mantenimiento del equipo Hydran 201i se reserva únicamente al personal perfectamente cualificado.
- Para una distancia máxima de 15 m (50 pies) de la fuente de alimentación, utilice un cable de 14-AWG (2,08 mm²) y una protección máxima 15-A contra las sobrecargas de corriente.

[DE] (in German) WARNUNG:

- Alle Abläufe in diesem Handbuch müssen strengstens befolgt werden.
- Jede Abweichung davon könnte dem zu überwachenden Transformator und/oder dem Hydran 201*i* unwiderrufliche Schäden zufügen, und könnte zu Sachschaden, Personenverletzung und/oder Tod führen.
- Installation und Wartung des Hydran 201*i* dürfen daher nur von qualifiziertem Personal durchgeführt werden.
- Für eine maximale Entfernung von 15 m von der Spannungsquelle, verwenden Sie ein 14 AWG Kabel (2.08 mm²) und einen 15 A Maximalüberstromschutz.

[IT] (in Italian) ATTENZIONE:

- Tutte le procedure del presente manuale dovranno essere eseguite in totale conformità.
- Qualsiasi deviazione dallo stesso manuale potrebbe causare danni irreversibili al trasformatore sotto monitoraggio e/o all' Hydran 201*i*, e potrebbe causare danni alla proprietà, lesioni personali e/o alla morte.
- L'installazione e la manutenzione del Hydran 201*i* devono essere eseguite solo ed esclusivamente da personale qualificato.
- A una distanza massima di 15 m dalla fonte di energia usare un cavo 14-AWG (2.08 mm²) e una protezione massima 15-A di sovracorrente.

[SV] (in Swedish) VARNING:

- Alla procedurer i manualen måste följas noggrant.
- Varje avvikelse från dessa procedurer kan orsaka oåterkalleliga skador på den övervakade transformatorn och/eller på Hydran 201*i* samt leda till egendomsförlust, personskada och/eller livsfara.
- Installation och underhåll av Hydran 201*i* måste utföras av behörig personal.
- För ett maximalt avstånd på 15 m från kraftuttaget, använd 2.08 mm² kabel (14-AWG) och ett överströmsskydd på maximalt 15 A.

PREFACE

This manual is a complete reference for the Hydran 201i System, which is a unique, continuous, on-line monitor of combustible gases in dielectric oils.

The information in this manual may be used by:

- Purchaser or specifier
- Installation planner
- Operator
- Commissioning manager
- Person responsible for collecting the readings
- Maintenance technician
- Troubleshooting technician

WARNING

All procedures in this manual must be strictly adhered to. Any deviation from these could cause irreversible damages to the transformer being monitored and/or the Hydran 201i System, and could lead to property damage, personal injury and/or death. Installation and maintenance of the Hydran 201i System must be carried out by qualified personnel only.

This manual is not a tutorial on combustible gases in dielectric oil. It is assumed that the reader is already familiar with these subjects.

This manual applies to the Hydran 201i System and to the Hydran 201R Model *i*. In this manual, the designation “Hydran 201i System” also applies to the Hydran 201R Model *i* and to any other combination of Hydran 201i components. The components of the Hydran 201i System are described in Section 1.2 on page 1-2.

To help the reader, a Table of Contents, a List of Figures and a List of Tables are present at the beginning of the manual, along with a Glossary in Appendix I at the end of the manual.

This *Hydran 201i System Instruction Manual* is included in PDF format in the folder **English/Manuals** of the Hydran 201i System installation CD, along with the *Hydran 201i System Installation Guide* and the *Hydran Host Software Manual*. A hard copy of all those manuals can be purchased from General Electric Canada.

PAGE LEFT INTENTIONALLY BLANK

DATES OF REVISIONS

All pages in this manual are labeled “Rev. 6, March 2011” since they all have been modified during this general revision.

Issue dates of this manual are:

Original (Rev. 1) . . . December 2007

Revision 2 February 2008

Revision 3 December 2008

Revision 4 January 2010

Revision 5 November 2010

Revision 6 March 2011

PAGE LEFT INTENTIONALLY BLANK

STANDARD GENERAL ELECTRIC CANADA WARRANTY

The products covered by this manual and manufactured by General Electric Canada (“Products”) are warranted to be free from defects in material, workmanship and title at the time of delivery. Any components of a Product or other products manufactured by persons other than General Electric Canada carry only the warranty provided by the manufacturers thereof and General Electric Canada gives no warranty on behalf of the manufacturers of such products.

General Electric Canada warrants the Products until 36 months from date of delivery (“Warranty Period”).

General Electric Canada represents and warrants that any software and firmware covered by this manual is free from functional deficiencies. If any functional deficiencies are discovered and are reported to General Electric Canada within the Warranty Period, General Electric Canada agrees to use due diligence to correct such deficiencies within 30 days after receipt of such notification. Upon receiving such notice, General Electric Canada may lend telephone support or patches. If the reported deficiencies cannot be eliminated within 30 days, the Buyer may request, and General Electric Canada shall then furnish, monthly status reports to the Buyer regarding the progress of General Electric Canada’s efforts to correct such functional deficiencies.

If Products covered by this manual do not meet the above warranties during the applicable Warranty Period, the Buyer shall promptly notify General Electric Canada in writing but not later than 30 days and make the Products available promptly for correction. General Electric Canada shall thereupon correct any defect by, at its option, repairing the defective Products or making available necessary replacement parts.

Any failure which is the basis for a warranty claim shall not be cause for extension of the duration of the applicable Warranty Period. General Electric Canada shall not be responsible for removal or replacement of systems, structures or other parts of the Buyer’s facility. If a defect in Products or part thereof cannot be corrected by General Electric Canada’s reasonable efforts, the parties shall negotiate an equitable adjustment in price with respect to such Products or part thereof. All decontamination work necessary for the correction of defects shall be performed by the Buyer at the Buyer’s expense. The condition of any tests shall be mutually agreed upon and General Electric Canada shall be notified of and may be represented at all tests that may be made.

General Electric Canada does not warrant Products or any repaired or replacement parts against normal wear and tear, including that due to environment or operation, including excessive operation at peak capability, frequent starting, type of fuel, detrimental air inlet conditions, or erosion, corrosion or material deposits from fluids, or which have been involved in an accident. The warranties and remedies set forth herein are further conditioned upon:

- Proper storage, installation, operation and maintenance of the Buyer's equipment and conformance with the instruction manuals (including revisions thereto) provided by General Electric Canada and/or its subcontractors, as applicable
- Repair or modification pursuant to General Electric Canada's instructions or approval

The Buyer shall keep proper records of operation and maintenance during the applicable Warranty Period. These records shall be kept in the form of log sheets and copies shall be submitted to General Electric Canada upon its request in connection with a warranty claim by the Buyer. General Electric Canada does not warrant any products or services of others designated by the Buyer where such products or services are not normally supplied by General Electric Canada.

The preceding paragraphs set forth the exclusive remedies for all claims based on failure of or defect in Products covered by this manual, whether the failure or defect arises before or during the applicable Warranty Period and whether a claim, however instituted, is based on contract, indemnity, warranty, tort (including negligence) or civil liability, strict liability or otherwise. The foregoing warranties are exclusive and are in lieu of all other warranties and guarantees whether written, oral, implied or statutory. **NO IMPLIED STATUTORY WARRANTY OF MERCHANTABILITY OR FITNESS FOR A PARTICULAR PURPOSE SHALL APPLY.**

TABLE OF CONTENTS

Notice of Copyright and Proprietary Rights	ii
Trademark Notices	ii
Safety Warnings in Six Languages	iii
Preface	v
Dates of Revisions	vii
Standard General Electric Canada Warranty	ix
Table of Contents	xi
List of Figures	xxiii
List of Tables	xxv

Chapter 1

Introduction

1.1 The Hydran 201i System	1-1
1.2 Components of the Hydran 201i System	1-2
1.2.1 Hydran 201Ti Intelligent Transmitter	1-2
1.2.2 Hydran 201Ci-C Communications Controller.	1-3
1.2.3 Hydran 201Ci-1 One-Channel Controller	1-4
1.2.4 Hydran Host Software	1-5
1.3 Networking and Communication Capabilities	1-6
1.4 Vocabulary and Abbreviations Used to Describe the Hydran 201i System.	1-7
1.5 Accessories	1-8
1.5.1 Hydran 201TW Tube Wrench.	1-8
1.5.2 Vibration-Absorbing Rubber Pads	1-8

Chapter 2

Hydran 201Ti Intelligent Transmitter

2.1 Features.	2-1
2.2 Enclosure	2-2
2.3 External Components	2-2
2.4 Internal Components.	2-4
2.4.1 Brass Adaptor	2-4
2.4.2 Heating Plate	2-5
2.4.3 Hydran 201 Sensor	2-6
2.4.4 CPU Module	2-7
2.4.5 DB-9 Male Connector for the RS-232 Link	2-7
2.4.6 I/O Module	2-7
2.4.6.1 Top Side of the I/O Module.	2-8
2.4.6.2 Left Side of the I/O Module.	2-10
2.4.6.3 Right Side of the I/O Module	2-11

2.5	Analog Inputs and Output	2-13
2.5.1	Analog Inputs	2-13
2.5.2	Analog Output	2-14
2.6	Heating System	2-14
2.7	Battery	2-15
2.7.1	Estimated Life	2-15
2.7.2	Disconnecting the Battery.	2-15
2.7.3	Replacing the Battery	2-17
2.8	Internal Clock.	2-19
2.9	Nonvolatile Memory	2-20
2.10	Additional Information	2-20

Chapter 3

Hydran 201Ci Controllers

3.1	Hydran 201Ci-C Communications Controller	3-1
3.1.1	Features.	3-1
3.1.2	Description of the Major Components	3-2
3.1.3	Description of the Circuit Board	3-4
3.1.4	Additional Information.	3-7
3.2	Hydran 201Ci-1 One-Channel Controller	3-7
3.2.1	Features.	3-7
3.2.2	Description of the Major Components	3-9
3.2.3	Description of the Circuit Board	3-10
3.2.4	Additional Information.	3-15

Chapter 4

Hydran 201Ti's Displays and Menus

4.1	User Interface.	4-1
4.2	User Interface Operating Modes	4-3
4.2.1	Unacknowledged Alarms Mode	4-3
4.2.2	Main Display Mode	4-4
4.2.3	Menu Navigation Mode	4-5
4.2.4	Parameter Modification Mode	4-6
4.2.5	Power-up Mode.	4-6
4.2.5.1	Normal Power-up (Power-off Longer Than Five Minutes)	4-6
4.2.5.2	Short Power-up (Power-off Shorter Than Five Minutes).	4-7
4.2.5.3	First Power-up (After Reconnection of Battery)	4-7
4.3	Using the Keypad's Keys According to Each Mode	4-7
4.4	Passwords	4-9

4.5	Main and Extended Menus	4-10
4.5.1	History Submenu	4-12
4.5.1.1	Events History	4-12
4.5.1.2	Short Term History	4-13
4.5.1.3	Long Term History	4-14
4.5.1.4	Service History.	4-14
4.5.1.5	History Setup (Extended Menu Only)	4-15
4.5.1.6	Clear Events (Extended Menu Only)	4-15
4.5.1.7	Clear Short Term (Extended Menu Only)	4-15
4.5.1.8	Clear Long Term (Extended Menu Only)	4-15
4.5.2	Gas Submenu	4-16
4.5.2.1	Gas Level	4-16
4.5.2.2	Hourly Trend	4-16
4.5.2.3	Daily Trend	4-17
4.5.3	Temperature Submenu.	4-17
4.5.4	Service Submenu	4-18
4.5.4.1	SensorCal Data.	4-18
4.5.4.2	ForceSensor Test	4-19
4.5.4.3	Battery	4-20
4.5.4.4	ServiceData	4-20
4.5.5	Date&Time Submenu (Extended Menu Only)	4-21
4.5.6	Communication Submenu (Extended Menu Only)	4-21
4.5.6.1	CommChannel and DefaultChannel	4-21
4.5.6.2	CommMode	4-22
4.5.6.3	BaudRate	4-22
4.5.6.4	Force HostCall	4-22
4.5.6.5	H201Ti ID and PowerStat. ID	4-23
4.5.7	Relays/Analog Submenu (Extended Menu Only)	4-23
4.5.7.1	Gas H Relay	4-23
4.5.7.2	Gas HH Relay	4-24
4.5.7.3	SysOK Relay	4-24
4.5.7.4	AnalogOut	4-24
4.5.7.5	TDM Out	4-25
4.5.8	NewSensor Submenu (Extended Menu Only).	4-25
4.5.9	Calibration Submenu (Extended Menu Only).	4-26

Chapter 5 Before Installation

5.1	General Warnings	5-1
-----	----------------------------	-----

5.2	Installation Overview	5-7
5.2.1	Tools and Material Required	5-9
5.2.2	Mounting Location of the Hydran 201 <i>Ti</i>	5-9
5.2.2.1	Warnings	5-9
5.2.2.2	Typical Locations	5-10
5.2.3	Mounting Location of Hydran 201 <i>Ci</i> Controllers	5-12
5.2.4	Cabling and Network Configuration.	5-13
5.2.4.1	Parameter Settings.	5-13
5.2.4.2	Cabling	5-14
5.3	Installation	5-15

Chapter 6
Hydran 201*Ti* Installation

6.1	Incoming Inspection and Verification	6-1
6.1.1	Receiving and Unpacking.	6-1
6.1.2	Shipping List.	6-2
6.1.3	Inspecting	6-3
6.1.4	Storage and Battery Care	6-5
6.2	Verification of Operation Prior to Installation	6-6
6.2.1	Preparation	6-6
6.2.2	Initial Observations	6-7
6.2.3	Adjusting the Date and Time	6-8
6.2.4	Verifying the Alarm Relays	6-9
6.2.4.1	Gas High Alarm	6-9
6.2.4.2	Gas High-High Alarm	6-10
6.2.4.3	Fail Alarm.	6-10
6.2.4.4	Cancelling the Fail Alarm.	6-11
6.2.4.5	Cancelling the Gas Alarms	6-11
6.2.4.6	Conclusion	6-12
6.2.5	Verifying the Backup Battery	6-12
6.2.6	Sensor Serial Number Verification and Sensor Test	6-12
6.2.7	Adjusting the Temperature Set Point	6-13
6.2.8	Verifying the Analog Output (Facultative)	6-14
6.2.9	Verifying the RS-232 Communication (Facultative)	6-15
6.2.10	Completing the Verification	6-17
6.3	Installation	6-17
6.3.1	Verifying the ac Power Supply Voltage and the Serial Numbers.	6-18
6.3.2	Preparing the Hydran 201 <i>Ti</i>	6-19
6.3.2.1	Removing the CPU Module	6-19
6.3.2.2	Separating the Brass Adaptor From the Heating Plate	6-20

6.3.2.3	Removing the Hydran 201 Sensor	6-20
6.3.2.4	Conclusion	6-20
6.3.3	Preparing the Valve	6-21
6.3.4	Installing the Brass Adaptor Onto the Valve	6-21
6.3.5	Installing the Hydran 201 Sensor	6-22
6.3.6	Opening the Valve	6-23
6.3.7	Fastening the Hydran 201Ti to the Brass Adaptor	6-24
6.3.8	Installing the Cable Conduits	6-25
6.3.9	Installing the Supervisory Link and Analog Output Cable	6-26
6.3.10	Installing the Alarms Cable (Facultative)	6-27
6.3.11	Installing the ac Power Supply Cable	6-27
6.3.12	Installing the CPU Module	6-28
6.3.13	Verifying the Hydran 201Ti Operation	6-28
6.4	Configuring the Hydran 201Ti	6-30
6.4.1	Setting the Communication Parameters for the Hydran Host Software	6-30
6.4.2	Verifying and Setting Historical Data File Parameters	6-31
6.4.3	Verifying and Setting Gas and Trend Alarm Parameters	6-31
6.4.4	Resetting the Hourly Trend, Daily Trend and Period B	6-32
6.4.5	Verifying and Setting the Temperature Parameters of the Hydran 201 Sensor	6-32
6.4.6	Verifying the Hydran 201 Sensor and Its Parameters	6-33
6.4.7	Verifying and Setting the Battery Alarm Parameters	6-33
6.4.8	Logging the Values of the Service Data	6-34
6.4.9	Verifying and Setting the Date and Time	6-34
6.4.10	Verifying and Setting the Communication Parameters	6-34
6.4.11	Verifying and Setting the Operation Mode of the Alarm Relays	6-35
6.4.12	Verifying and Setting the Fail Alarm Conditions	6-35
6.4.13	Verifying and Setting the Operation Mode of the Analog Output and TDM Signal	6-35
6.4.14	Conclusion	6-35
6.5	Fastening the Hydran 201Ti's Cover	6-36
6.6	Commissioning	6-36
6.7	Other Installations.	6-36

Chapter 7

Hydran 201Ci-C Installation

7.1	Incoming Inspection and Verification	7-1
7.1.1	Receiving and Unpacking	7-1
7.1.2	Inspecting.	7-1
7.1.3	Storage.	7-2

7.2	Verification of Operation Prior to Installation	7-2
7.2.1	Preparation	7-2
7.2.2	Initial Observations	7-3
7.2.3	Verification of RS-232 and RS-485 Communications	7-4
7.2.4	Completing the Verification	7-6
7.3	Installation	7-6
7.3.1	Verifying the ac Power Supply Voltage and the Serial Numbers.	7-7
7.3.2	Installing the Enclosure	7-7
7.3.3	Installing the Cable Conduits	7-7
7.3.4	Installing the Supervisory Link Cables.	7-8
7.3.5	Installing the ac Power Supply Cable	7-9
7.3.6	Verifying the Operation	7-9
7.3.7	Verifying the Supervisory Link Communications	7-9
7.3.8	Conclusion	7-10
7.4	Other Installations	7-10

Chapter 8

Hydran 201Ci-1 Installation

8.1	Incoming Inspection and Verification	8-1
8.1.1	Receiving and Unpacking.	8-1
8.1.2	Inspecting	8-1
8.1.3	Storage	8-2
8.2	Verification of Operation Prior to Installation	8-2
8.2.1	Preparation	8-3
8.2.2	Initial Observations	8-3
8.2.3	Verifying the Analog Output	8-4
8.2.4	Verifying the Alarm Indicators and Relays	8-6
8.2.4.1	Gas High Alarm	8-6
8.2.4.2	Gas High-High Alarm	8-7
8.2.4.3	System Fault Alarm	8-7
8.2.4.4	System Fault Alarm Cleared.	8-8
8.2.4.5	Gas Alarms Cleared	8-8
8.2.4.6	Conclusion	8-9
8.2.5	Verifying the RS-232 Communication.	8-9
8.2.6	Conclusion	8-10
8.3	Installation	8-11
8.3.1	Verifying the ac Power Supply Voltage and the Serial Numbers.	8-11
8.3.2	Installing the Enclosure	8-11
8.3.3	Installing the Cable Conduits	8-12
8.3.4	Installing the Supervisory Link Cable	8-12
8.3.5	Installing the Analog Output Cable (Facultative).	8-13

8.3.6	Installing the Alarms Cable (Facultative)	8-13
8.3.7	Installing the ac Power Supply Cable	8-14
8.3.8	Verifying the Operation	8-14
8.3.9	Verifying the Analog Outputs	8-14
8.3.10	Verifying Alarm Indicators and Alarm Relays	8-15
8.3.11	Verifying the Supervisory Link Communications	8-15
8.3.12	Conclusion	8-15
8.4	Other Installations	8-15

Chapter 9

Communications and Networking

9.1	Communications Within a Hydran 201R Model <i>i</i> or a Hydran 201i System, Using a Supervisory Link	9-1
9.1.1	TDM Pulse	9-2
9.2	Communications in a Network, Using an RS-485 Local Network Link	9-3
9.3	Communications With a Host Computer, Using an RS-232 Serial Communication Link	9-5
9.3.1	Local Communications	9-6
9.3.2	Remote Communications (via Modem)	9-6
9.4	Communication Protocol	9-8
9.5	Local Network Installation	9-8
9.5.1	Installing an RS-485 Local Network Link Between Hydran 201 <i>Ci</i> Controllers	9-9
9.5.2	Connecting a Host Computer to a Hydran 201 <i>Ci</i> Controller in a Local Network, Using an RS-232 Cable	9-10
9.5.3	Verifying RS-232 and RS-485 Communications	9-10
9.6	Optional Modem Installation	9-11
9.6.1	Connecting a Telephone Line	9-11
9.6.2	Verifying Communications Between the Two Modems	9-11
9.6.3	Configuring the Call OnAlarm Mode	9-13

Chapter 10

Alarms

10.1	Alarm Levels	10-2
10.1.1	Alarm Conditions	10-2
10.1.2	Purpose of Hourly and Daily Trends	10-3
10.2	Alarm Relays	10-4
10.2.1	Alarm Contacts	10-4
10.2.2	Status of Alarm Relays	10-4
10.2.3	Operation Modes of Alarm Relays	10-5
10.2.3.1	Normal Mode	10-6

10.2.3.2	Latch Mode	10-6
10.2.3.3	Force OFF	10-7
10.2.3.4	Force ON	10-7
10.3	Alarm Interface	10-7
10.4	Gas High and High-High Alarms	10-8
10.4.1	Alarm Parameters Setting	10-9
10.4.1.1	Gas Level	10-9
10.4.1.2	Hourly Trend.	10-10
10.4.1.3	Daily Trend	10-10
10.4.2	Guidelines for Setting Trend Alarms	10-11
10.4.3	Hourly and Daily Trend Computations	10-12
10.4.4	High and High-High Alarms Triggering	10-13
10.4.5	High and High-High Alarms Cancellation	10-13
10.5	Fail Alarm	10-14
10.5.1	Fail Alarm Triggering	10-14
10.5.2	Fault Triggers	10-15
10.5.2.1	Gas Fault Triggers.	10-15
10.5.2.2	Sensor Temperature Fault Triggers	10-16
10.5.2.3	Battery Voltage Fault Triggers	10-16
10.5.2.4	Sensor Operation and Connections Fault Triggers	10-17
10.5.3	Fail Alarm Cancellation	10-17

Chapter 11
Operating the Hydran 201i System

11.1	Operating Methods.	11-1
11.1.1	Periodic, Visual Monitoring	11-1
11.1.1.1	Method Drawbacks	11-2
11.1.2	Alarm Monitoring.	11-2
11.1.2.1	Method Drawbacks	11-2
11.1.3	Analog Output Monitoring	11-3
11.1.3.1	Method Drawbacks	11-3
11.1.3.2	Conclusion	11-4
11.1.4	Combined Alarm and Analog Output Monitoring	11-4
11.1.5	Local Monitoring With Host Computer	11-4
11.1.5.1	Method Benefits	11-5
11.1.6	Remote Monitoring With Host Computer	11-5
11.2	Data Reading	11-5
11.2.1	Direct Data Reading	11-6
11.2.2	Historic Data Reading	11-6
11.3	Data Analysis.	11-6

Chapter 12

Troubleshooting

12.1 Alarm Messages on the Hydran 201 <i>Ti</i> 's Display	12-1
12.1.1 Battery L	12-2
12.1.2 Battery LL	12-2
12.1.3 CableOpen	12-2
12.1.4 CableShort	12-4
12.1.5 DayTrend H.	12-4
12.1.6 DayTrend HH	12-5
12.1.7 DayTrend L	12-5
12.1.8 DayTrend LL	12-6
12.1.9 Gas H	12-7
12.1.10 Gas HH	12-7
12.1.11 Gas L	12-7
12.1.12 Gas LL	12-8
12.1.13 HourTrend H	12-8
12.1.14 HourTrend HH.	12-8
12.1.15 HourTrend L	12-9
12.1.16 HourTrend LL	12-9
12.1.17 Replace SensNOW	12-10
12.1.18 Replace SensSoon	12-10
12.1.19 Sensor Not Inst!	12-11
12.1.20 SensTemp H.	12-12
12.1.21 SensTemp HH	12-12
12.1.22 SensTemp L.	12-13
12.1.23 SensTemp LL	12-13
12.1.24 Setup Lost	12-13
12.2 RS-232 and/or RS-485 Communications	12-14
12.2.1 No Communication When the Host Computer is Connected Directly or by Modem to the Hydran 201 <i>Ti</i> 's DB-9 Connector	12-14
12.2.2 No Communication When the Host Computer is Connected Directly or by Modem to the Hydran 201 <i>Ci</i> Controller's DB-9 or USB Connector.	12-15
12.2.3 No Communication Between the Host Computer and the Network of Hydran 201 <i>i</i> Systems	12-15
12.3 Hydran 201 <i>Ci</i> Controller's Display Is Blank	12-16
12.4 Hydran 201 <i>Ti</i> and Hydran 201 <i>Ci</i> Controller's Analog Outputs at Zero	12-16
12.5 Alarms	12-17
12.5.1 Fail Alarm Is Triggered	12-17
12.5.2 Fail Alarm Message Displayed in the Hydran Host Software.	12-17
12.5.3 Intermittent Gas Alarms Are Occurring	12-17

12.5.4 An Alarm Relay Does Not Reset, Even If the Alarm Condition Has Disappeared 12-17

12.5.5 Irregular Gas Readings 12-18

12.5.6 Inaccurate Gas Readings 12-18

12.5.7 Gas Level Reading Is Abnormally High 12-19

12.5.8 Gas Level Reading Is Slowly Decreasing Toward Zero 12-19

Chapter 13
Maintenance

13.1 Historic Data Verification 13-2

13.2 Dissolved Gas Analysis (DGA). 13-3

13.3 Hydran 201Ti Verification. 13-4

13.4 Hydran 201Ci Controller Verification 13-6

13.5 Fuse 13-7

Appendix A
Technical Specifications for the Hydran 201i System

A.1 Hydran 201Ti Intelligent Transmitter A-1

A.2 Hydran 201Ci-C Communications Controller A-4

A.3 Hydran 201Ci-1 One-Channel Controller A-6

Appendix B
Mechanical Drawings

B.1 Hydran 201Ti Intelligent Transmitter B-1

B.2 Hydran 201Ci-C Communications Controller B-5

B.3 Hydran 201Ci-1 One-Channel Controller B-6

Appendix C
Functional Block Diagrams

C.1 Hydran 201Ti Intelligent Transmitter C-1

C.2 Hydran 201Ci-C Communications Controller C-2

C.3 Hydran 201Ci-1 One-Channel Controller C-3

Appendix D
Terminal Blocks and Connectors

D.1 Hydran 201Ti Intelligent Transmitter D-1

D.2 Hydran 201Ci-C Communications Controller D-5

D.3 Hydran 201Ci-1 One-Channel Controller D-8

Appendix E
Hydran 201Ti's History File Messages

Appendix F
Default Values of the Parameters

Appendix G
Unit Conversions

G.1 Converting Current to Voltage	G-1
G.2 Converting ppm to mA (or Vice Versa)	G-1

Appendix H
Extracting an Oil Sample

Appendix I
Glossary

PAGE LEFT INTENTIONALLY BLANK

LIST OF FIGURES

Figure 1-1 - Hydran 201 <i>Ti</i> Intelligent Transmitter	1-3
Figure 1-2 - Hydran 201 <i>Ci-C</i> Communications Controller	1-4
Figure 1-3 - Hydran 201 <i>Ci-1</i> One-Channel Controller	1-5
Figure 1-4 - Hydran 201 <i>TW</i> Tube Wrench	1-8
Figure 1-5 - Vibration-Absorbing Rubber Pads	1-9
Figure 2-1 - Hydran 201 <i>Ti</i> 's Enclosure (Mounted on a Valve)	2-3
Figure 2-2 - Internal View of the Hydran 201 <i>Ti</i>	2-5
Figure 2-3 - Hydran 201 Sensor	2-6
Figure 2-4 - First View of the Top Side of the I/O Module	2-8
Figure 2-5 - Second View of the Top Side of the I/O Module	2-9
Figure 2-6 - Left Side of the I/O Module	2-10
Figure 2-7 - Right Side of the I/O Module	2-12
Figure 3-1 - Typical Configuration of a Hydran 201 <i>i</i> System	3-1
Figure 3-2 - Internal View of the Hydran 201 <i>Ci-C</i>	3-3
Figure 3-3 - Circuit Board of the Hydran 201 <i>Ci-C</i>	3-5
Figure 3-4 - Hydran 201 <i>R</i> Model <i>i</i>	3-8
Figure 3-5 - External View of the Hydran 201 <i>Ci-1</i>	3-9
Figure 3-6 - Internal View of the Hydran 201 <i>Ci-1</i>	3-11
Figure 3-7 - Circuit Board of the Hydran 201 <i>Ci-1</i>	3-12
Figure 4-1 - Hydran 201 <i>Ti</i> 's User Interface	4-2
Figure 4-2 - Hydran 201 <i>Ti</i> 's Keypad	4-8
Figure 5-1 - H201 <i>Ti</i> 's Serial Number and Protective Cap	5-1
Figure 5-2 - Do Not Touch the Membrane	5-2
Figure 5-3 - Do Not Paint the Sensor or Clean It With Any Solvent	5-3
Figure 5-4 - Use the Hydran 201 <i>TW</i> Instead of a Pipe Wrench	5-4
Figure 5-5 - Do Not Install the H201 <i>Ti</i> on the Inlet Side of the Radiator Pump	5-5
Figure 5-6 - Do Not Install the H201 <i>Ti</i> on an Elbow	5-6
Figure 5-7 - Avoid High-Pressure Water Streams	5-6
Figure 5-8 - Typical Installation of the Hydran 201 <i>i</i> System	5-8
Figure 5-9 - Mounting Locations of the H201 <i>Ti</i> on a Transformer	5-10
Figure 6-1 - Example of Test Certificate and Data Sheet for the Hydran 201 <i>Ti</i>	6-4

Figure 6-2 - Hydran 201Ti Assembly	6-18
Figure 6-3 - Screws Used to Fasten the CPU Module	6-19
Figure 6-4 - Always Cover the Threads of the Adaptor and Sensor With Teflon Tape	6-21
Figure 6-5 - Ensure Two Screw Holes of the Adaptor Are Level	6-22
Figure 6-6 - The Bleed Screw Must Be on Top, at the 12 O'clock Position	6-23
Figure 6-7 - Purging Air From the Hydran 201 Sensor	6-24
Figure 6-8 - Fastening the Heating Plate to the Brass Adaptor	6-25
Figure 6-9 - Installing the CPU Module	6-29
Figure 9-1 - Example of Local Network	9-4
Figure 9-2 - Host Computer Connection Modes in a Hydran 201R Model <i>i</i>	9-5
Figure 9-3 - Typical Communication Configuration With a Modem	9-7
Figure B-1 - Hydran 201Ti Dimensions	B-1
Figure B-2 - Hydran 201 Sensor	B-1
Figure B-3 - 1.5-In Adaptor	B-2
Figure B-4 - 1-In Adaptor	B-3
Figure B-5 - 2-In Adaptor	B-4
Figure B-6 - Finned High-Temperature Adaptor	B-4
Figure B-7 - Hydran 201Ci-C Dimensions	B-5
Figure B-8 - Hydran 201Ci-1 Dimensions	B-6
Figure C-1 - Functional Block Diagram for the Hydran 201Ti	C-1
Figure C-2 - Functional Block Diagram for the Hydran 201Ci-C	C-2
Figure C-3 - Functional Block Diagram for the Hydran 201Ci-C	C-3
Figure D-1 - Wiring Diagram for Active Current Output	D-4
Figure D-2 - Wiring Diagram for Passive Current Output	D-4
Figure D-3 - Wiring of RS-485 Link Cable Between Two or More H201Ci-C's or H201Ci-1's	D-11
Figure H-1 - Extracting an Oil Sample From the Hydran 201 Sensor's Sampling Port Using a Glass Syringe and a 5/32-In Allen Key	H-2

LIST OF TABLES

Table 2-1 - Estimated Battery Life According to Time	2-16
Table 4-1 - Messages Displayed in the Main Display Mode	4-5
Table 4-2 - Self-Test Sequence During the Normal Power-up	4-6
Table 4-3 - Values Requested During the First Power-up Sequence.	4-7
Table 4-4 - Functions of the Keypad's Keys According to the Operating Modes.	4-8
Table 4-5 - Functions of the Submenus of the H201Ti's Embedded Software.	4-10
Table 4-6 - Messages That Can Be Displayed Following a Sensor Test	4-20
Table 4-7 - Electrical Current Generated by the Analog Output for Each Operation Mode	4-25
Table 5-1 - Example of H201Ti Identification Numbers	5-14
Table 9-1 - Alarm Relay States, and Status of the H201Ti, TDM Signal and H201Ci-1.	9-3
Table 9-2 - Wiring for Serial Cables	9-10
Table 10-1 - Alarm Conditions Monitored by the Hydran 201Ti	10-3
Table 10-2 - Possible States of the Alarm Contacts.	10-5
Table 10-3 - Possible States of the Hydran 201Ci-1's Display and Alarm Indicators.	10-8
Table 10-4 - Suggested Guidelines for Setting the Gas Level High Alarm Condition.	10-10
Table 10-5 - Evolution of the Hourly Trend	10-12
Table 10-6 - Evolution of the Daily Trend	10-12
Table 10-7 - Gas Fault Triggers	10-16
Table 10-8 - Sensor Temperature Fault Triggers.	10-16
Table 10-9 - Battery Voltage Fault Triggers	10-17
Table 10-10 -Sensor Operation and Connections Fault Triggers.	10-17
Table 13-1 - Maintenance Routines and Their Frequency	13-2
Table 13-2 - Examples of Gas Reading Comparisons Between a DGA and a Hydran 201Ti	13-4
Table D-1 - ac Power Supply: 3-Terminal Block, J3 Connector and Fuse.	D-1
Table D-2 - Alarm Contacts 9-Terminal Block and J5 Connector	D-1
Table D-3 - SW1 Voltage Selector.	D-2

Table D-4 - J2 Heater 6-Pin Connector	D-2
Table D-5 - J1 Sensor 4-Pin Connector and J2 Thermistor 2-Pin Connector	D-2
Table D-6 - J3 Local Analog Output Connector, J4 Isolated Supervisory Link Connector, and Termination Board	D-3
Table D-7 - DB-9 Male RS-232 Connector (Back of CPU Module)	D-4
Table D-8 - Main Terminal Block for the Hydran 201Ci-C	D-5
Table D-9 - SW1 Voltage Selector for the Hydran 201Ci-C	D-7
Table D-10 - J10 DB-9 Male RS-232 Connector for the Hydran 201Ci-C	D-8
Table D-11 - Main Terminal Block for the Hydran 201Ci-1.	D-8
Table D-12 - SW1 Voltage Selector for the Hydran 201Ci-1	D-11
Table D-13 - J10 DB-9 Male RS-232 Connector for the Hydran 201Ci-1	D-11
Table F-1 - Default Values of the Parameters.	F-1

This Chapter is an introduction to the Hydran 201*i* System. A description of the various components of the system is also provided.

1.1 THE HYDRAN 201*i* SYSTEM

The Hydran 201*i* System is a continuous, on-line, intelligent dissolved gas monitoring system. Its uncompromising accuracy and reliability, and its features are key to its worldwide acceptance as a true transformer fault prevention device:

- A direct and continuous combustible gas-in-oil digital reading (0–2,000 ppm H₂)
- An isolated, analog 4–20 mA output
- Two adjustable gas alarm set points
- A System Fail alarm
- A sensor test feature
- A very wide temperature range for all-weather outdoor operation
- An extremely high immunity to electrical surges, radio-frequency interferences and electrostatic discharges

Besides these essential characteristics, the Hydran 201*Ti* intelligent dissolved-gas monitor enjoys the benefits of full digital processing and is equipped with the following additional high-value features:

- Adjustable hourly and daily gas trend computation (ppm change during the target period) with alarming
- History logging of data and events with date and time stamping
- Serial communications with a host computer (RS-232 or RS-485)
- Networking capabilities (up to 128 units) and modem control
- Self-test on power-up
- All-software calibration
- Remote or local configuration and program upgrading
- Hydran Host computer software available from General Electric Canada
- Full stand-alone capabilities when the host computer is not needed
- Sensor self-test and sensor status

The Hydran 201*i* System consists of an Intelligent Transmitter, named the Hydran 201*Ti*, and a family of Controllers, collectively named the Hydran 201*Ci* Controllers.

When the Hydran 201*Ti* Intelligent Transmitter is combined with the Hydran 201*Ci*-1 One-Channel Controller, it is called a Hydran 201R Model *i* Incipient Fault Monitor. A Hydran 201*Ti* being used alone or with other Hydran 201*Ci* Controllers is named a Hydran 201*i* System Incipient Fault Monitor.

Both the Hydran 201R Model *i* and the Hydran 201*i* System Incipient Fault Monitors can be networked. The network can be tied to a Supervisory Control and Data Acquisition (SCADA) computer with a single RS-232 line, either locally at the substation or remotely through a telephone line and modem.

1.2 COMPONENTS OF THE HYDRAN 201*i* SYSTEM

1.2.1 Hydran 201*Ti* Intelligent Transmitter

The Hydran 201*Ti* Intelligent Transmitter (Figure 1-1 on page 1-3) is the foundation upon which the Hydran 201*i* System is built. It consists of a small cylindrical enclosure which attaches directly to a transformer valve using a brass adaptor. This enclosure contains a standard Hydran sensor, a thermal conditioning system and a microprocessor-based intelligent electronic transmitter.

Terminal blocks are provided for easy connection of: ac power; alarm contacts (Gas High, Gas High-High and System Fail); supervisory link; and one isolated, analog 4–20 mA output. An RS-232 connector is provided for local computer interface.

A membrane keypad and an alphanumeric, backlit, LCD display enable full interaction with the unit without requiring the use of an external computer.

The H201*Ti* is described in detail in Chapter 2.



Figure 1-1 - Hydran 201Ti Intelligent Transmitter

1.2.2 Hydran 201Ci-C Communications Controller

The Hydran 201Ci-C unit (Figure 1-2 on page 1-4) is a communications controller. It can supervise up to four Hydran 201Ti Intelligent Transmitters through the isolated supervisory link, typically a transformer bank (A, B, C and sometimes an auxiliary). The Hydran 201Ci-C does not have a display, nor does it provide alarm or analog outputs. It is meant specifically to interface with a network of H201Ti Intelligent Transmitters to a computer via an RS-232, RS-485 or USB link, or an optional modem.



Figure 1-2 - Hydran 201Ci-C Communications Controller

The H201Ci-C is built into the same heated Type NEMA 4X instrument cabinet as the H201Ci-1 (Section 1.2.3 on page 1-4), but without a display nor alarms; it contains a single electronic digital circuit board that handles communications chores. Two terminal block stripes are provided for easy connection to ac power. Connectors are used for communications: RS-232 or USB to a computer or an optional modem; isolated supervisory link to H201Ti Intelligent Transmitters (four connectors); and RS-485 to other H201Ci Controllers.

The H201Ci-C is described in detail in Section 3.1 on page 3-1.

1.2.3 Hydran 201Ci-1 One-Channel Controller

The Hydran 201Ci-1 (Figure 1-3 on page 1-5) is a full one-channel controller. When used with the Hydran 201Ti Intelligent Transmitter, the combination is called a Hydran 201R Model *i* (see the picture on the front cover of this manual). It uses a heated Type NEMA 4X instrument cabinet and contains a single electronic circuit board. The digital/analog board handles communications chores and provides display, alarm and analog output functions.



Figure 1-3 - Hydran 201Ci-1 One-Channel Controller

Two terminal block stripes are provided for easy connection of: ac power; alarm contacts (Gas High, Gas High-High and System Fail); configurable isolated analog output; and isolated supervisory link to the Hydran 201Ti Intelligent Transmitter. Connectors are used for communications: RS-232 or USB to a computer or optional modem, and RS-485 to other Hydran 201Ci Controllers.

A large LED digital display shows the gas concentration in ppm. Two gas alarm indicators are mounted on the front door.

The H201Ci-1 is described in detail in Section 3.2 on page 3-7.

1.2.4 Hydran Host Software

General Electric Canada's Hydran Host software provides a simple interface between one or more Hydran 201Ti Intelligent Transmitters and an IBM PC (or compatible), through a standard RS-232 communication port (DB-9 connector). Optional modems allow the communication to be carried over public telephone lines.

The Hydran Host software performs five basic tasks:

- A continuous, on-line survey of alarm status and basic information from one or several H201Ti's
- Real-time logging of information from one or several H201Ti's
- Continuous or programmed uploading of historical data (history download) from one or several H201Ti network(s) with graphic display
- Downloading and uploading of configuration data (H201Ti set-up) to one or several H201Ti's from/to the host computer
- H201Ti embedded program upgrading of one or several H201Ti's

1.3 NETWORKING AND COMMUNICATION CAPABILITIES

Up to 128 Hydran 201Ti Intelligent Transmitters can be connected in a single network and monitored and controlled by computer (either locally or remotely through a modem) using one RS-232 communication port. This is accomplished by connecting groups of one to four H201Ti's to a Hydran 201Ci-C Controller via an isolated supervisory link, and then connecting the many H201Ci Controllers via an isolated RS-485 LAN.

Each supervisory link is isolated to a level of 2,000 V RMS, both at the H201Ti end and at the H201Ci end. Individual transmitters can be wired directly to their group controller if the total cable length does not exceed 1,200 m (4,000 ft).

The supervisory links and the RS-485 LAN are electrically isolated and all H201Ci's on a network share a single reference ground. The H201Ci's are networked together in a daisy-chain fashion. Usually, the H201Ci's are to be found in a well-defined area of a substation (such as a control building) but the RS-485 LAN can have a total length of 1,200 m (4,000 ft) if required. For 32 H201Ci's, this gives an average distance of 40 m (120 ft) between each H201Ci.

Although the RS-485 LAN is electrically separate from the multiple supervisory links, the entire system forms a single logical network and each of the H201Ti's, up to a maximum of 128, can be called by the supervisory computer using the Gas Monitor Address of the transmitter (a user-defined number from 1 to 254 specific to each H201Ti).

The supervisory computer can be indifferently connected to the RS-232 or USB port of any of the H201Ci's since each H201Ci automatically routes communications to and from its RS-232 or USB computer port, isolated supervisory link port and isolated RS-485 LAN

port. More than one computer can be connected to the network as long as only one is communicating at the same moment.

When an optional smart modem is installed in a H201*Ci*, the network can be accessed through the public telephone system. The H201*Ci* manages modem operation to allow receiving and handling phone calls from distant modems, and properly ending the calls. Conversely, the modem is instructed to dial a distant modem if an alarm is sensed in a H201*Ti* (unless this function is disabled by the user).

1.4 VOCABULARY AND ABBREVIATIONS USED TO DESCRIBE THE HYDRAN 201*I* SYSTEM

The Hydran 201*i* System is made up of different units assembled in several possible configurations to provide a variety of useful combinations for the detection and monitoring of failure conditions in oil-filled electrical equipment. The following vocabulary and abbreviations are used to describe the main components of this system:

- Hydran 201*Ti* Intelligent Transmitter: The basic building block; includes the sensor; can be used in full stand-alone mode. Can be abbreviated as follows:
 - H201*Ti* Intelligent Transmitter
 - H201*Ti* Transmitter
 - H201*Ti*
- Hydran 201*Ci*-1 One-Channel Controller: Combined with one H201*Ti*. Can be abbreviated as follows:
 - H201*Ci*-1 One-Channel Controller
 - H201*Ci*-1 Controller
 - H201*Ci*-1
- Hydran 201*Ci*-C Communications Controller: Allows computer supervision of up to four H201*Ti*'s. Can be abbreviated as follows:
 - H201*Ci*-C Communications Controller
 - H201*Ci*-C Controller
 - H201*Ci*-C
- Hydran 201*Ci* Controller: Generic designation of H201*Ci*-1 and/or H201*Ci*-C. Can be abbreviated as follows:
 - H201*Ci* Controller
 - H201*Ci*
- Hydran 201R Model *i* Incipient Fault Monitor: Made of a H201*Ti* plus a H201*Ci*-1. Can be abbreviated as follows:
 - Hydran 201R Model *i*

- Hydran 201*i* System Incipient Fault Monitor: Combination of H201Ti's and H201Ci's. Can be abbreviated as follows:
 - Hydran 201*i* System
- Hydran Host Software: Used for interface between the user and a network of H201Ti's. Can be abbreviated as follows:
 - Hydran Host

1.5 ACCESSORIES

The following accessories are available for the Hydran 201*i* System. They may be ordered from General Electric Canada with any of the Hydran 201*i* System components or separately.

1.5.1 Hydran 201TW Tube Wrench

The Hydran 201TW Tube Wrench (Figure 1-4 on page 1-8) is required to properly install the Hydran 201 sensor. One Tube Wrench per site is recommended.

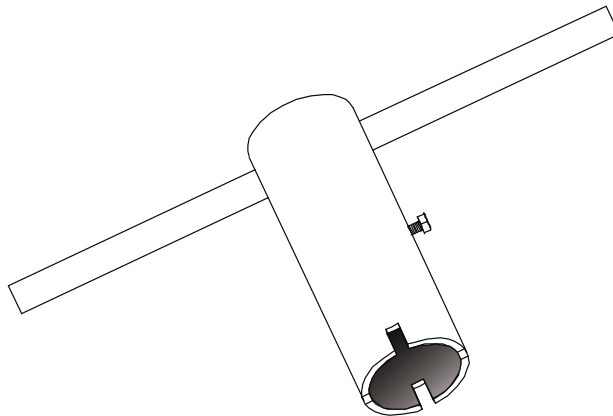

Figure 1-4 - Hydran 201TW Tube Wrench

1.5.2 Vibration-Absorbing Rubber Pads

If vibrations are present, these rubber pads (which can be purchased from General Electric Canada) are used on the back of the Hydran 201*Ci* Controllers; an example is shown in Figure 1-5 on page 1-9. Refer to Chapter 3.

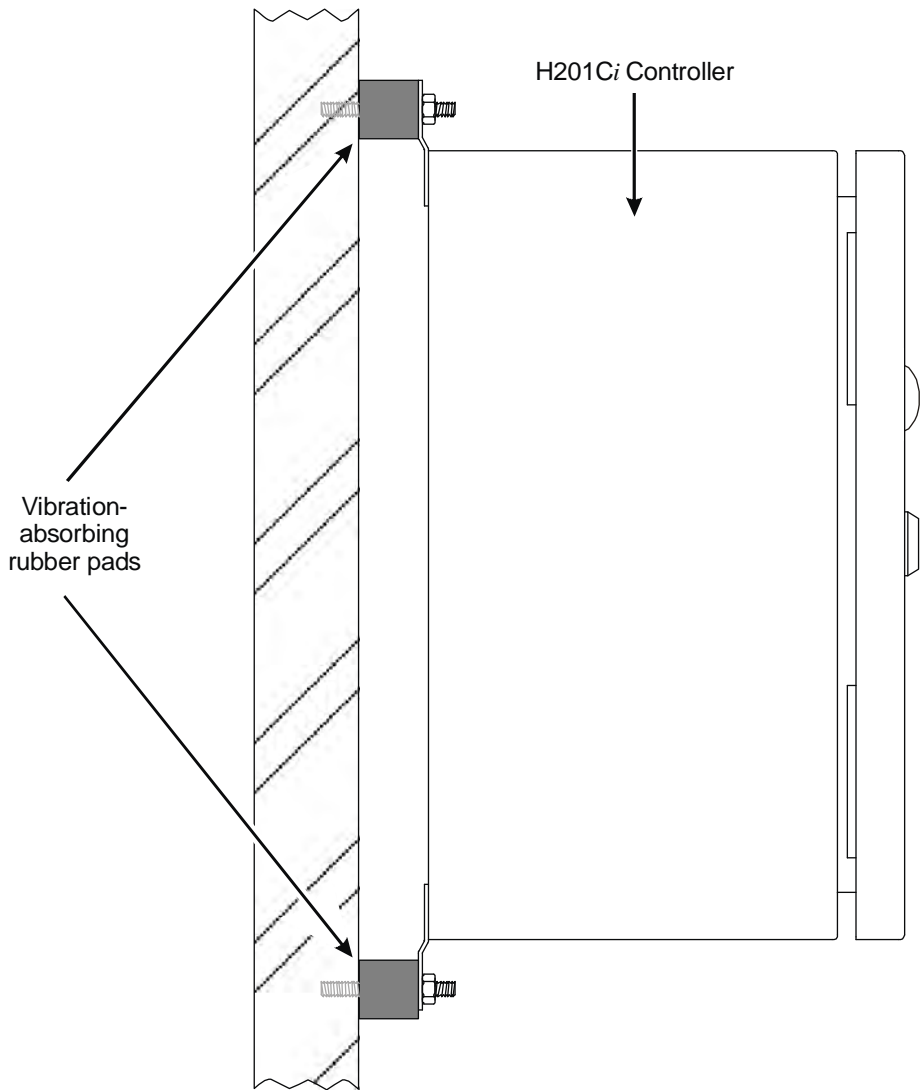

Figure 1-5 - Vibration-Absorbing Rubber Pads

PAGE LEFT INTENTIONALLY BLANK

Hydran 201Ti Intelligent Transmitter

The Hydran 201Ti is an intelligent, on-line monitoring system that measures the level of combustible gases in dielectric oil for the early detection and monitoring of incipient faults in transformers or any other oil-filled electrical equipment.

A picture of the H201Ti can be found in Figure 1-1 on page 1-3.

2.1 FEATURES

The main features of the Hydran 201Ti are:

- A Hydran 201 sensor that measures a composite value of the following dissolved gases in oil: hydrogen (H₂), carbon monoxide (CO), acetylene (C₂H₂) and ethylene (C₂H₄)
- Easy installation on a valve of the equipment to be monitored
- A six-key membrane keypad
- A backlit, alphanumeric, liquid crystal display (LCD) to use the H201Ti without a host computer. Provides the following on-line information:
 - Level of dissolved gases in oil
 - Hourly trend (gas level variation during a period of time measured in hours)
 - Daily trend (gas level variation during a period of time measured in days)
 - Alarm messages
- Three alarms:
 - Two gas alarms (High and High-High; levels are adjustable), triggered by the gas level, and the hourly and daily trends
 - One system fail alarm, triggered by several conditions
- Four historic data files (automatic recording of data):
 - Events (recording at the time of events; example: alarms)
 - Short Term and Long Term (recording at fixed, adjustable logging rates)
 - Service (recording at the time of the sensor tests)
- Semimonthly, automatic sensor test and state report
- Digital calibration of the analog inputs and output
- Isolated, analog 4–20 mA output
- An extremely high immunity to electrical surges, radio-frequency interferences and electrostatic discharges

- A DB-9 connector for local RS-232 serial communication with a host computer running the Hydran Host software
- Serial communication with a Hydran 201Ci Controller through a supervisory link (communication cable between a H201Ti and a H201Ci)
- Full stand-alone capabilities when the host computer (running the Hydran Host software) is not used
- A very wide temperature range for all-weather outdoor operation
- A thermal regulating system
- Terminal blocks to connect the following components:
 - ac power supply
 - Alarm contacts (gas High and High-High, and system fail alarms)
 - Analog output
- A termination board to connect the H201Ci and the H201Ti with a supervisory link

2.2 ENCLOSURE

The Hydran 201Ti's enclosure (see Figure 1-1 on page 1-3) is 186 mm (7.3 in) in diameter by 180 mm (7.125 in) in length; for details, see Figure B-1 on page B-1. It serves three functions:

- To provide mechanical and weather protections for the Hydran 201 sensor and the H201Ti's electronic circuits
- To maintain the H201 sensor and the H201Ti electronics between 25 and 50 °C (77 and 122 °F) under extreme ambient and oil temperatures
- Using the dynamic oil sampling system, to stimulate oil movement in front of the H201 sensor to ensure representative sampling at all times

2.3 EXTERNAL COMPONENTS

Here is a description of the Hydran 201Ti's external components (see Figure 2-1 on page 2-3):

1. **Display Window:** The aluminum cover has a window to see the LCD display. The display and the keypad are located on the CPU module (Section 2.4.4 on page 2-7).
2. **Connection Box:** It is mounted on the external side of the heating plate, under the valve. It has a removable, watertight cover and two holes to install standard conduit fittings (for watertight, rigid or flexible steel conduits).

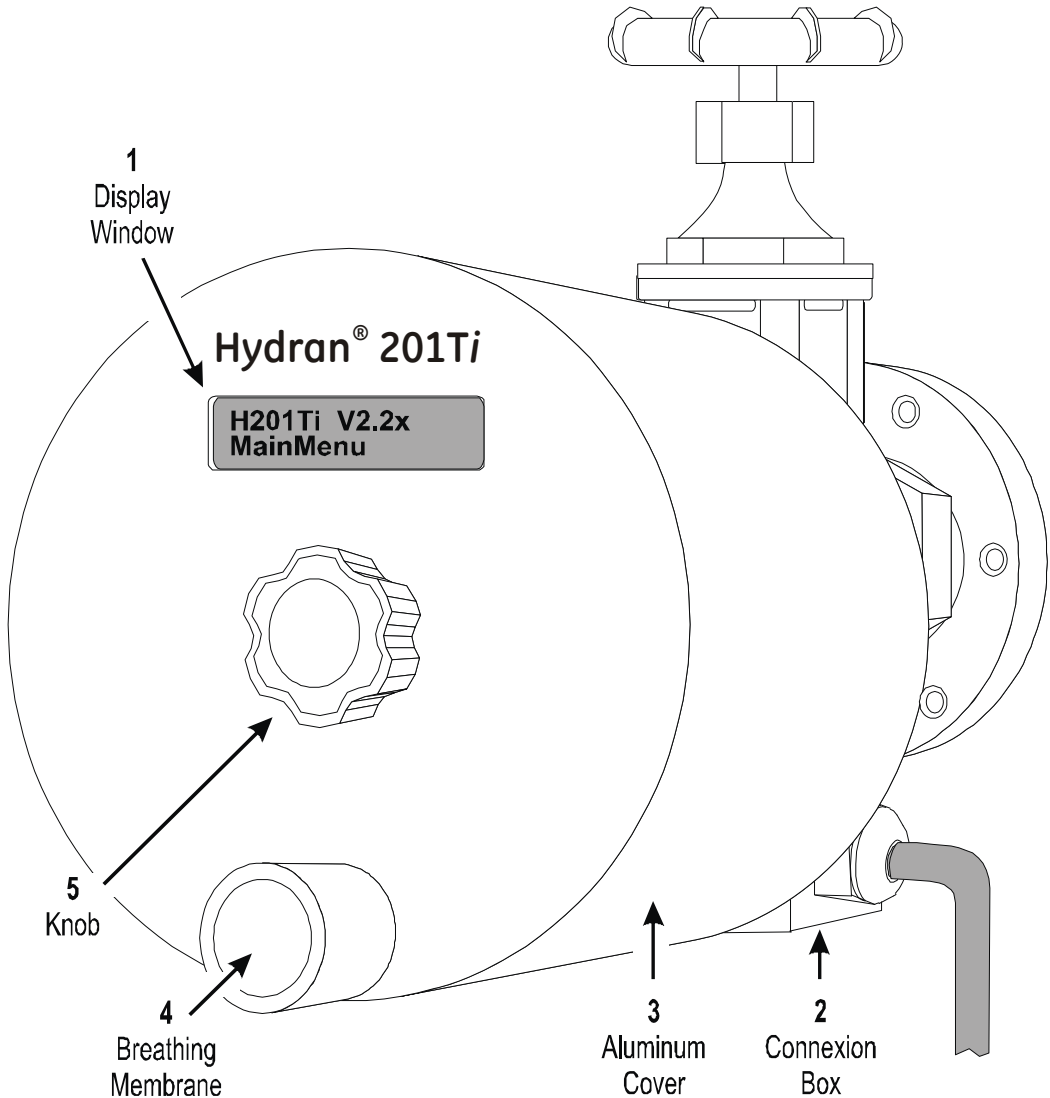

Figure 2-1 - Hydran 201Ti's Enclosure (Mounted on a Valve)

3. **Aluminum Cover:** It acts as a radiator, thus allowing the enclosure to maintain the temperature of the sensor and electronics between 25 and 50 °C (77 and 122 °F), regardless of the ambient or oil temperature. The H201Ti controls the power input to the heating plate. The cover is easily removed for access to the H201 sensor and its oil sampling port.

4. **Breathing Membrane:** This Gore* porous membrane is impervious but allows oxygen to penetrate inside the H201Ti. The H201 sensor requires oxygen to detect the dissolved gases in oil.
5. **Knob:** It maintains the aluminum cover in place.

2.4 INTERNAL COMPONENTS

An internal view of the Hydran 201Ti is presented in Figure 2-2 on page 2-5. The major components are described in this Section:

1. *Brass adaptor:* See Section 2.4.1 on page 2-4.
2. *Heating plate:* See Section 2.4.2 on page 2-5.
3. *Hydran 201 sensor:* See Section 2.4.3 on page 2-6.
4. *CPU module:* See Section 2.4.4 on page 2-7.
5. *DB-9 male connector for the RS-232 link:* See Section 2.4.5 on page 2-7.
6. *I/O module:* See Section 2.4.6 on page 2-7.
7. *Connection box:* See item 2 on page 2-2.

2.4.1 Brass Adaptor

The Hydran 201Ti and the Hydran 201 sensor mount onto the valve of the transformer or other electrical equipment using a flanged brass adaptor (item 1 in Figure 2-2 on page 2-5). This adaptor has male threads at one end that screw directly onto the transformer valve, and female threads at the other end to which the sensor is screwed. The heating plate of the H201Ti's enclosure bolts onto the adaptor flange. The H201Ti can thus be installed or replaced without removing the adaptor and the sensor from the transformer valve.

The standard brass adaptor (Figure B-3 on page B-2) has 1.5-in NPT male threads (internal diameter of 38 mm) on the valve side. It can also be purchased from General Electric Canada with 1- or 2-in NPT sizes (25 or 51 mm) male threads (Figure B-4 on page B-3 and Figure B-5 on page B-4). The female threads of the adaptor are 1-in NPT (25 mm) to adapt to the threads of the H201 sensor.

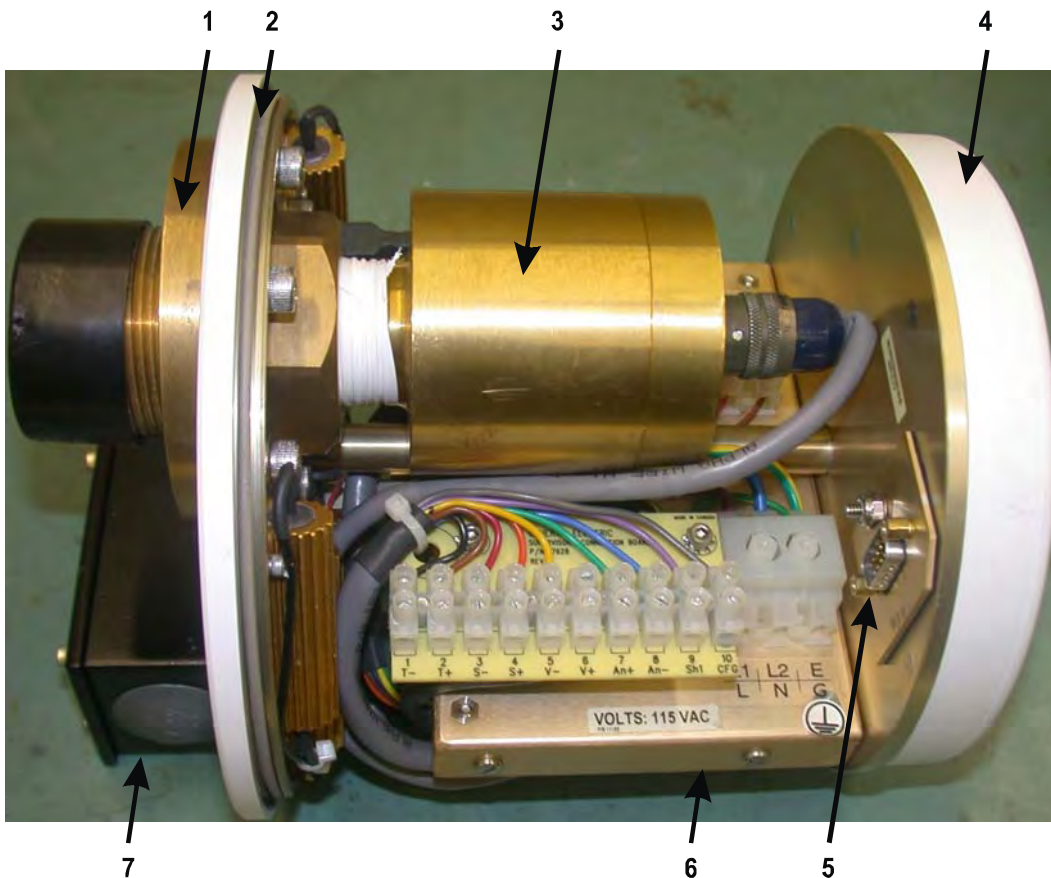

Figure 2-2 - Internal View of the Hydran 201Ti

A finned high-temperature adaptor (1.5-in NPT only) can also be purchased (Figure B-6 on page B-4) to increase the maximum operating temperature of the H201Ti.

2.4.2 Heating Plate

Military-grade heating resistors and a temperature-sensing thermistor are mounted on the heating plate (item 2 in Figure 2-2 on page 2-5). The power input to the heating plate is controlled by the Hydran 201Ti and the aluminum cover (item 3 in Figure 2-1 on page 2-3) acts as a heat radiator. This allows the enclosure to maintain the temperature of the Hydran 201 sensor (and electronics) between 25 and 50 °C (77 and 122 °F), regardless of the ambient or oil temperatures. For details, see Section 2.6 on page 2-14.

2.4.3 Hydran 201 Sensor

WARNING Mishandling of the H201 sensor (such as a perforation or scratch on the membrane or subjecting the sensor to paint or solvent) voids the warranty.

The Hydran 201 sensor (see Figure 2-3 on page 2-6) consists of a brass body with the following components:

- 1-in NPT (25 mm) conical threads at one end.
- The male cable connector, the oxygen breathing hole and the sensor's serial number at the other end.
- On the top, a sampling port and a bleed screw allow easy sampling of the oil for Dissolved Gas Analysis (DGA). The sampling port fits the Luer stopcock valve of a syringe; this port is also used for purging during the installation.
- A thermistor is incorporated in the sensor's body to measure its temperature and, using mathematical computations, compensate the effect of the temperature on the detector's signal.

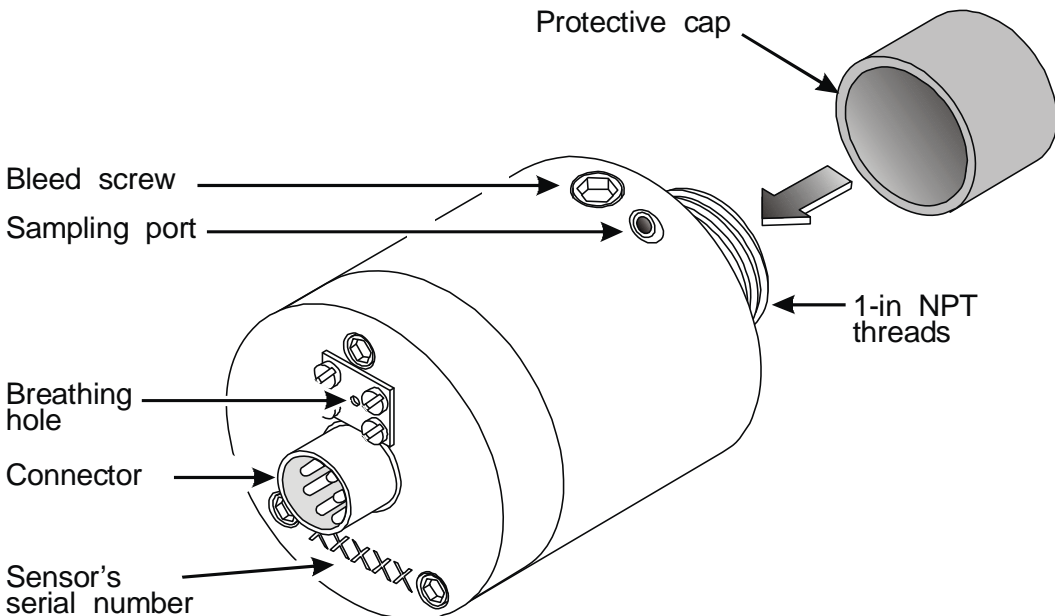

Figure 2-3 - Hydran 201 Sensor

Combustible gases dissolved in the oil pass through a selectively-permeable membrane into an electrochemical gas detector (located inside the H201 sensor). Within the detector, the gases combine with oxygen to produce an electrical signal that is then measured by an electronic circuit and converted to ppm. The H201 sensor is sensitive to hydrogen (H_2), carbon monoxide (CO), ethylene (C_2H_4) and acetylene (C_2H_2) which are the primary indicators of incipient faults in oil-filled electrical equipment.

2.4.4 CPU Module

The CPU module (item 4 in Figure 2-2 on page 2-5) contains a microprocessor which is the brain of the Hydran 201Ti. It is built as a circular, flat case. It fits snugly over the H201Ti's center post and attaches to the I/O module (Section 2.4.6 on page 2-7) using only two screws. Should the need arise, the CPU module can be replaced very easily.

On the back side of the CPU module, a surge-protected DB-9 male connector supports an RS-232 communication port, and a 36-pin connector mates with the I/O module.

A six-key membrane keypad and a liquid crystal display (LCD), consisting of two lines of 16 characters, are located on the front of the CPU module. Their operation and the menu system are explained in Chapter 4.

2.4.5 DB-9 Male Connector for the RS-232 Link

Located on the back of the CPU module (item 4 in Figure 2-2 on page 2-5), the DB-9 male connector (item 5 in Figure 2-2 on page 2-5) allows local RS-232 communications between the H201Ti and a host computer. This connector is protected against surges. For wiring details, see Table D-7 on page D-4.

2.4.6 I/O Module

The Inputs/Outputs (I/O) module is built as an odd-shaped case that attaches to the Hydran 201Ti's heating plate by means of three screws accessed from the outside. It can thus be replaced rapidly, should it be required.

The I/O module consists of the following components:

- Regulated power supply
- All I/O circuits
- Hydran 201 sensor's analog circuit

- Alarm relays
- Supervisory link manager

2.4.6.1 Top Side of the I/O Module

The top side of the I/O module supports five components:

8. *ac Power 3-Terminal Block* (in Figure 2-4 on page 2-8): The terminal has a 300-V rating and accepts 22–14 AWG wires (2.5 mm² nominal). For wiring details, see Table D-1 on page D-1.

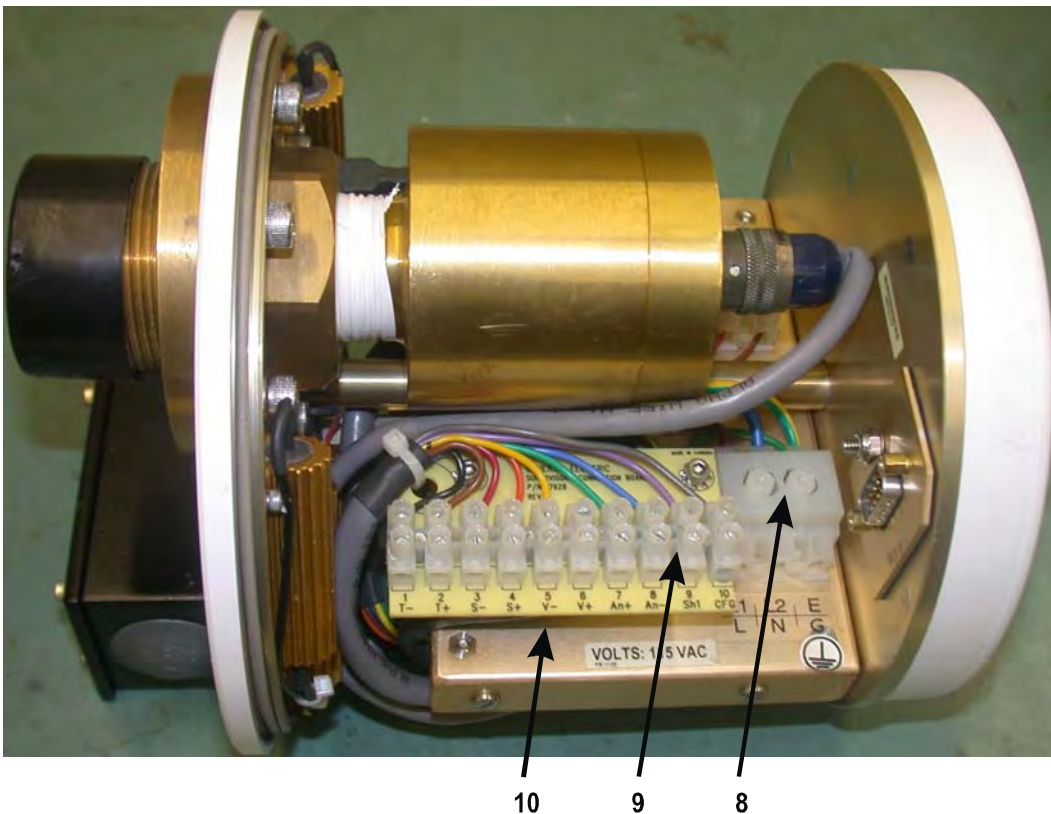

Figure 2-4 - First View of the Top Side of the I/O Module

9. *Supervisory Link and Analog Output Termination Board* (in Figure 2-4 on page 2-8): The terminal has a 300-V rating and accepts 26–14 AWG wires (1.5 mm² nominal).

It is protected against the surges and the electromagnetic interferences. For wiring details, see Table D-6 on page D-3.

Note: The Hydran 201R Model i uses a 9-m (30-ft) 6-conductor cable for the supervisory link. Other configurations use either 4- or 6-conductor cables of varying lengths.

10. *ac Line EMI Filter* (in Figure 2-4 on page 2-8): The line filter, located beneath the Supervisory Link and Analog Output Termination Board (item 9 on page 2-8), blocks the electromagnetic interferences conducted in the ac power supply.
11. *Thermostat* (in Figure 2-5 on page 2-9): It stops the heating whenever the base plate temperature exceeds 100 °C.

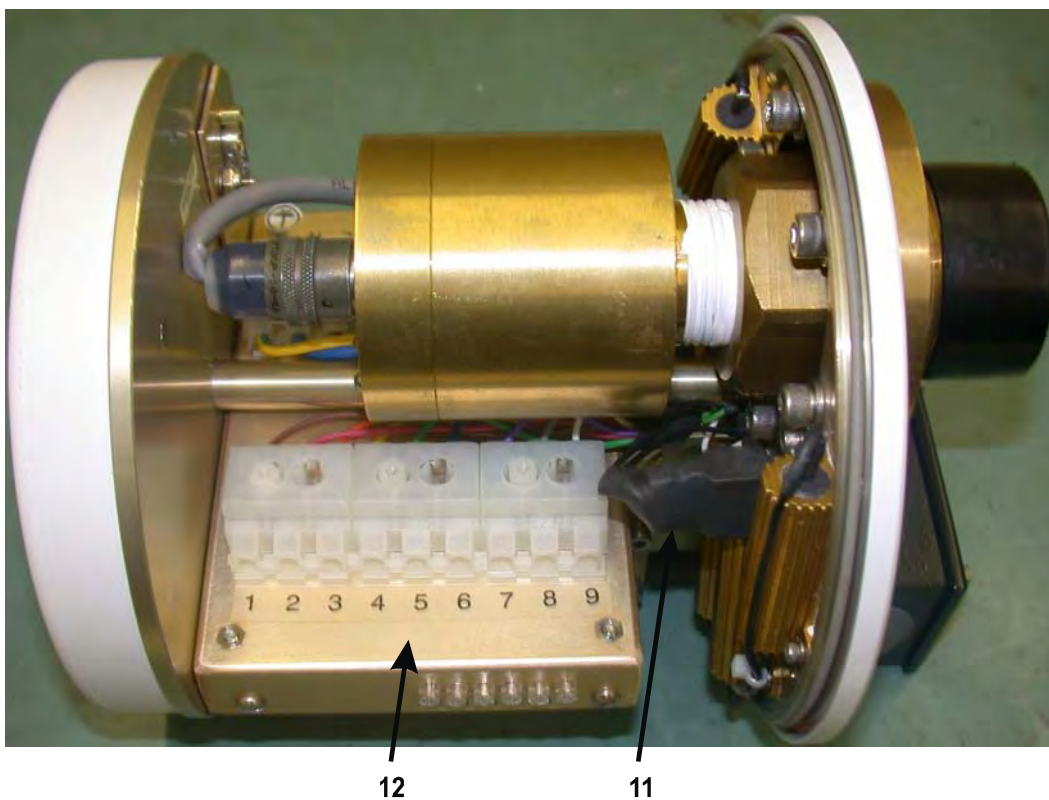

Figure 2-5 - Second View of the Top Side of the I/O Module

- 12. *Alarm Contacts 9-Terminal Block* (in Figure 2-5 on page 2-9): The terminal has a 300-V rating and accepts 22–14 AWG wires (2.5 mm² nominal). For wiring details, see Table D-2 on page D-1.

2.4.6.2 Left Side of the I/O Module

The left side of the I/O module (Figure 2-6 on page 2-10) supports plug connectors and the fuse. An extremely high degree of electrical and environmental protection is assured by a covering plate over the connecting zone.

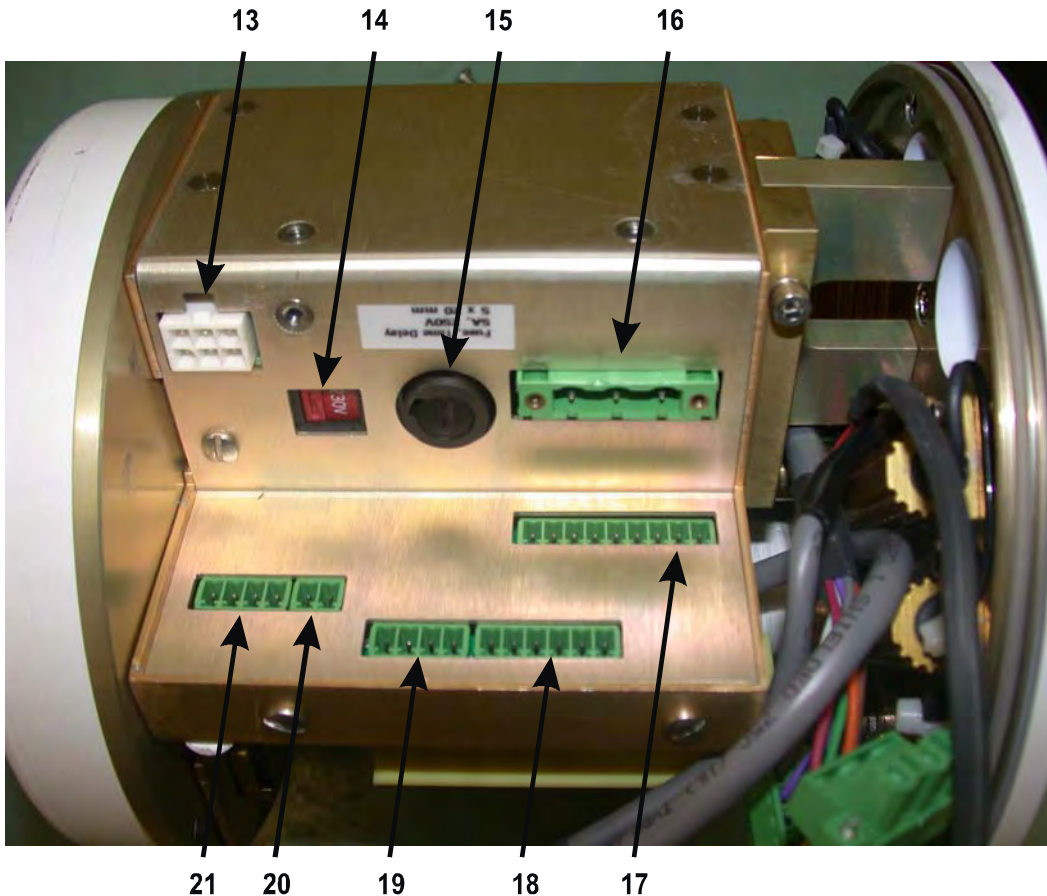



Figure 2-6 - Left Side of the I/O Module

13. *J2 Heater 6-Pin Connector*: This connector is factory-wired to the heating resistors of the Hydran 201Ti's heating plate. For wiring details, see Table D-4 on page D-2.
14. *SW1 Voltage Selector*: For wiring details, see Table D-3 on page D-2. This selector is used to choose between the following:
 - 115 V, corresponding to a 90–132 Vac range from 47 to 63 Hz
 - 230 V, corresponding to a 180–264 Vac range from 47 to 63 Hz
15. *F3 ac Line Fuse*: The fuse holder is a standard 5 x 20 mm holder.
16. *J3 ac Line 3-Pin Connector*: This connector is factory-wired to the line filter.
17. *J5 Alarm Relays 9-Pin Connector*: This connector is factory-wired to the alarm contacts terminal block.
18. *J4 Isolated Supervisory Link 6-Pin Connector*: This connector is wired to the termination board. For wiring details, see Table D-6 on page D-3.
19. *J3 Local Analog Output 4-Pin Connector*: This connector is wired to the supervisory link terminal block. The 4–20 mA output is isolated. For wiring details, see Table D-6 on page D-3.
20. *J2 Thermistor 2-Pin Connector*: This connector is factory-wired to the heating plate thermistor. For wiring details, see Table D-5 on page D-2.
21. *J1 Sensor 4-Pin Connector*: This connector is factory-wired to the Hydran 201 sensor. For wiring details, see Table D-5 on page D-2.

2.4.6.3 Right Side of the I/O Module

The right side of the I/O module (Figure 2-7 on page 2-12) carries six small LED diagnostic indicators.

22.  - **Heating state LED**: This yellow LED flashes once every five seconds in proportion to the amount of power supplied to the heating plate.
 - The LED remains lit if the internal temperature is below the set point (adjustable **Temp SetPoint** parameter in the **Temperature;DynOil Sampl** submenu).

- It flashes if the internal temperature is close to the set point.
 - It remains off if the internal temperature exceeds the set point.
23. **-5 - Regulated -5 Vdc supply LED:** This dim, green LED confirms the presence of the -5 Vdc power supply.
24. **+5 - Regulated +5 Vdc supply LED:** This dim, green LED confirms the presence of the +5 Vdc power supply.

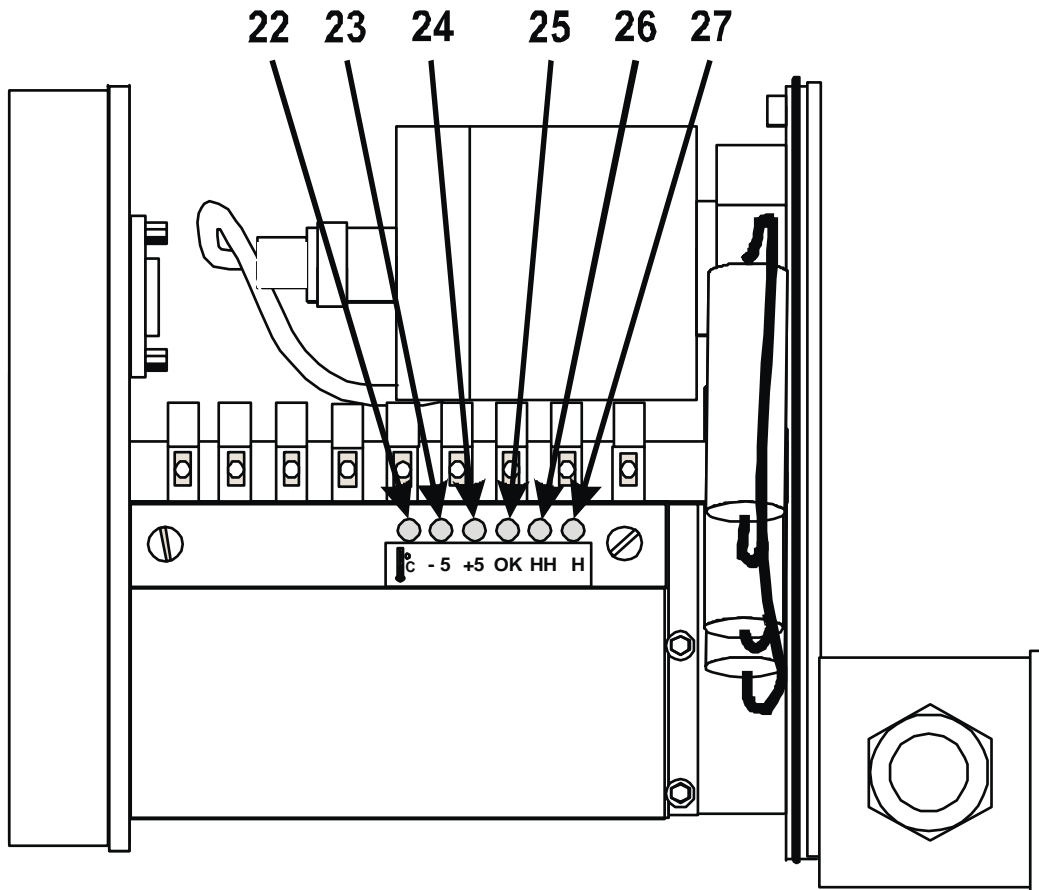

Figure 2-7 - Right Side of the I/O Module

25. **OK - System status indicator LED:** This green LED confirms that the Hydran 201Ti is operating properly and that the fail alarm relay is energized. It turns off if a fail alarm condition is detected and if the fail alarm relay is de-energized.
26. **HH - High-High alarm LED:** This red LED is lit when a High-High alarm condition is detected and the High-High alarm relay is energized.
27. **H - High alarm LED:** This red LED is lit when a High alarm condition is detected and the High alarm relay is energized.

2.5 ANALOG INPUTS AND OUTPUT

2.5.1 Analog Inputs

The Hydran 201Ti uses three analog inputs:

- Gas level reading (supplied by the Hydran 201 sensor)
- Temperature of the H201 sensor (supplied by the sensor thermistor)
- Temperature of the heating plate (supplied by the heating plate thermistor)

All H201Ti's inputs pass in a first level of processing which has the following functions:

- To protect the H201Ti against interferences and surges
- To filter out (low-pass) the noise from signals
- To convert the signals in voltage
- To amplify the signals

Next, the signals go through an analog/digital converter so the microprocessor can use them.

- Two calibration constants (offset and slope) are used to convert the signal from the H201 sensor.
- Three calibration constants (short circuit, open circuit and a mid-scale value) are required to convert (nonlinear) the signals from the thermistors.

The sensor signal is in microvolts (μV). It is first divided in two scales; then, these two signals go through the analog/digital converter and finally the two digital values are read by the microprocessor. The two scales are:

- Low scale, which ranges from 0 to 4,000 μV .
- High scale, which ranges from 0 to 40,000 μV .

The thermistor signals are in ohms (Ω ; 3,000 Ω at 25 °C). These two signals also go through the analog/digital converter and are then read by the microprocessor.

2.5.2 Analog Output

The isolated (up to 2,000 V RMS) analog 4–20 mA current output can supply a load ranging from 0 to 500 Ω (10 V maximum). It is used with a SCADA system.

For details on how to use the analog output, see Appendix G; for wiring details, see Table D-6 on page D-3.

2.6 HEATING SYSTEM

The recommended operating temperature range of the Hydran 201 sensor is 15 to 65 °C (59 to 149 °F). The sensor temperature is a function of:

- The ambient air temperature surrounding the Hydran 201Ti.
- The oil temperature behind the valve on which the H201Ti is mounted.

Note: This temperature is always lower than the oil temperature at the top of the transformer tank.

- The thermal regulation of the H201Ti's temperature.

Regardless of the oil or ambient temperature, the H201Ti is designed (heating and passive cooling) to maintain the sensor temperature between 25 and 45 °C (77 and 113 °F), if the set-point (**Temp SetPoint** parameter in the **Temperature;DynOil Sampl** submenu; see Section 4.5.3 on page 4-17) is set to the recommended temperature of 35 °C (95 °F).

The H201Ti's microprocessor measures the temperature and controls the heating power. A fail alarm is triggered (if on; see the **FaultTrig**. parameters in Section 4.5.7.3 on page 4-24) when the sensor temperature is outside the operating limits.

Temperatures are obtained through thermistors incorporated in the sensor body and the heating plate. The heating plate power is controlled using a time-proportioning regulating method. The proportional algorithm maintains the sensor temperature near the desired set point, by modulating it with the dynamic oil sampling system. The heating plate temperature is limited to 100 °C (212 °F); its variation rate is also controlled to avoid sensor overheating.

Detection of an open thermistor shuts the heating power off. In addition, a thermostat (item 11 in Figure 2-5 on page 2-9) with a 100 °C (212 °F) rating is located on the heating plate to protect against any fault from the heating system.

2.7 BATTERY

The Hydran 201Ti's battery is used to keep the real-time clock functioning and to retain the parameter values and historic data when ac power is not available.

The battery is a lithium/manganese dioxide cell (1,000 mAh) with a service life of approximately ten years, an extremely low self-discharge (1 % per year at 25 °C [77 °F]) and an operating temperature range of 10 to 70 °C (50 to 158 °F). This type of battery is used in critical conditions in the majority of military, industrial and commercial applications.

2.7.1 Estimated Life

A new battery delivers 3.0 V for about one half of its life and then its voltage starts dropping.

Because the Hydran 201Ti requires a minimum of 2.2 V, the set points of battery alarms (see **Service;Battery** submenu in Section 4.5.4.3 on page 4-20) are adjusted to provide warning delays of nine months (Low alarm = 2.75 V) and three months (Low-Low alarm = 2.45 V) when operating at 60 °C (140 °F). These delays are doubled at 25 °C (77 °F).

The estimated battery life according to time is shown in Table 2-1 on page 2-16.

2.7.2 Disconnecting the Battery

It is recommended to disconnect the battery if the Hydran 201Ti has to be stored for six months or more.

Table 2-1 - Estimated Battery Life According to Time

Possible Situations	25 °C (77 °F)	45 °C (113 °F)	60 °C (140 °F)
Battery disconnected, shelf life (20 % loss)	<< 10 years (1 %/year)	< 6 years (3 %/year)	< 2 years (10 %/year)
Battery connected, ac power on (100 % loss)	<< 10 years (5 %/year)	< 10 years (8 %/year)	< 4 years (24 %/year)
Battery connected, ac power off (100 % loss)	> 4 years (22 %/year)	> 3 years (33 %/year)	> 1 year (98 %/year)

The battery must be replaced when its voltage is too low (battery Low or Low-Low alarm). To remove the battery, proceed as follows:

Note: Step 1 below can be skipped if the H201Ti was never put in service and if the H201Ti's default parameter values have not been changed.

1. Because the historic data and most H201Ti's parameters (alarm set points, etc.) are lost when the battery is disconnected, they must all be recorded. There are two methods:
 - Use the Hydran Host software. For connection details, see Chapter 9; for details on the software, see the *Hydran Host Software Manual*.
 - Historic data are transferred automatically as soon as the communication is established between the software and the H201Ti. The **Histo Download in Progress...** message remains displayed in the lower right corner of the Hydran Host **Network Survey** window during the transfer.
 - Use the **Global Config** window to transfer the H201Ti's adjustable parameters (see the *Hydran Host Software Manual*).
 - Finally, note manually *all* parameters in the H201Ti's **Communication** submenu. These parameters are the only ones that cannot be accessed from the Hydran Host software.
 - If the Hydran Host software cannot be used, note manually the content in the four files of historic data (for details, see Section 4.5.1 on page 4-12) and the values of *all* H201Ti's adjustable parameters. This method is more difficult and can be source of errors.

Note: When disconnecting the battery, only the sensor parameters (except the serial number and checksum) and the calibration parameters are preserved. When the battery is connected again, the parameters are automatically set to their hardware default values.

2. Power off the H201Ti.
3. Disconnect the H201Ti's power supply.
4. Remove the two screws holding the CPU module (these screws are identified with arrows).
5. Pull out the module with care from the H201Ti.
6. Place the module on a table.
7. Remove the three remaining screws.
8. Carefully lift off the cover of the CPU module.

WARNING Wires connect the cover and the circuit board.

9. To disconnect the battery, simply remove the JP5 jumper, located next to the battery wires.
10. Put the jumper aside.
11. If the battery is disconnected for storage purposes, use tape to stick the jumper inside the CPU module's cover.
12. Reinstall the cover back in place.

2.7.3 Replacing the Battery

To replace the battery, proceed as follows:

1. Unsolder the red (W8) and blue (W9) wires coming from the battery.
2. Remove the battery from the cover.

3. Install the new battery inside the CPU module's cover.
4. Solder the wires from the new battery to the same locations on the circuit board: Red (+) to W8 and blue (-) to W9.

Note: If preferred, battery wires can be cut and spliced back.

5. Reinstall the JP5 jumper to reconnect the battery.
6. Replace the cover on the CPU module.
7. Fasten the cover using the three screws removed during step 7 on page 2-17.
8. Verify the state of the connector pins.
9. Reinstall carefully the CPU module on the H201Ti.
10. Fasten the CPU module with the two screws removed during step 4 on page 2-17.
11. Reconnect the H201Ti's power supply.
12. Power on the H201Ti. The H201Ti executes the self-test sequence as described in Section 4.2.5 on page 4-6.
13. When requested, use the H201Ti's keypad to enter:
 - The date and time
 - The identification number of the H201Ti
 - The identification number of the power station

Note: Except for the Hydran 201 sensor and its calibration parameters, all H201Ti's parameters are now set to their hardware default values.

14. Using the Hydran Host software or the H201Ti's keypad, enter the values noted during step 1 on page 2-16.

Note: Use the Hydran Host software to quickly restore the H201Ti's adjustable parameters.

15. Discard the removed battery.



Do not disassemble, crush, puncture or incinerate the battery. Handle a damaged or leaking battery with extreme care. If you touch the electrolyte, wash the exposed skin with soap and water. If the electrolyte contacts your eye, flush the eye with water for 15 minutes. If you have inhaled the electrolyte, move to fresh air, and monitor breathing and circulation. In each case, seek immediate medical attention. When discarding a battery, follow applicable safety procedures or contact your local waste disposal provider regarding local restrictions on the disposal or recycling of batteries.



This product contains a battery that cannot be disposed of as unsorted municipal waste in the European Union. See the product documentation for specific battery information. The battery is marked with this symbol, which may include lettering to indicate cadmium (Cd), lead (Pb), or mercury (Hg). For proper recycling return the battery to your supplier or to a designated collection point. For more information see www.recyclethis.info.

2.8 INTERNAL CLOCK

An internal real-time clock (RTC) circuit provides a calendar and a permanent clock, unless the battery is disconnected. The clock uses a crystal oscillator as its time base; its 0.01 % accuracy (four minutes per month) is independent of the ac power supply frequency.

Note: The calendar accounts automatically for leap years (366 days). However, it does not include daylight saving functions.

The Hydran 201Ti's internal clock allows to manage the following features:

- Historic data files (see Section 4.5.1 on page 4-12)
- Delays of all alarm conditions (see Chapter 10)
- Semimonthly, automatic sensor tests (see Section 4.5.4.2 on page 4-19)

The H201Ti's date and time are set in the **Date&Time** submenu (see Section 4.5.5 on page 4-21).

2.9 NONVOLATILE MEMORY

The nonvolatile memory allows the Hydran 201Ti to retain its data even during the following events:

- Disconnection of the H201Ti's battery
- Failure of the H201Ti's power supply
- Update of the H201Ti's embedded software using the Hydran Host software

The H201Ti's nonvolatile memory is used to retain the following data:

- The ten parameters of the Hydran 201 sensor (see Section 4.5.4.1 on page 4-18 and Section 4.5.8 on page 4-25)
- The calibration data (see Section 4.5.9 on page 4-26 and Appendix G)

2.10 ADDITIONAL INFORMATION

To obtain more information on the Hydran 201Ti, please consult the following parts of this manual:

- Displays and menus: See Chapter 4.
- Before the installation: See Chapter 5.
- Installation: See Chapter 6.
- Communications and networking: See Chapter 9.
- Alarms: See Chapter 10.
- Operation: See Chapter 11.
- Troubleshooting: See Chapter 12.
- Maintenance: See Chapter 13.
- Technical specifications: See Section A.1 on page A-1.
- Mechanical drawings: See Section B.1 on page B-1.
- Functional block diagram: See Section C.1 on page C-1.
- Terminal blocks and connectors: See Section D.1 on page D-1.
- History file messages: See Appendix E.
- Default values of the parameters: See Appendix F.
- Calibration: See Appendix G.

Hydran 201*Ci* Controllers

3.1 HYDRAN 201*Ci*-C COMMUNICATIONS CONTROLLER

Figure 3-1 on page 3-1 shows one possible configuration of a Hydran 201*i* System. It consists of three components:

- A host computer
- The Hydran 201*Ci*-C Communications Controller, which is described in detail in Section 3.1 on page 3-1
- The Hydran 201*Ti* Intelligent Transmitter, already described in Chapter 2

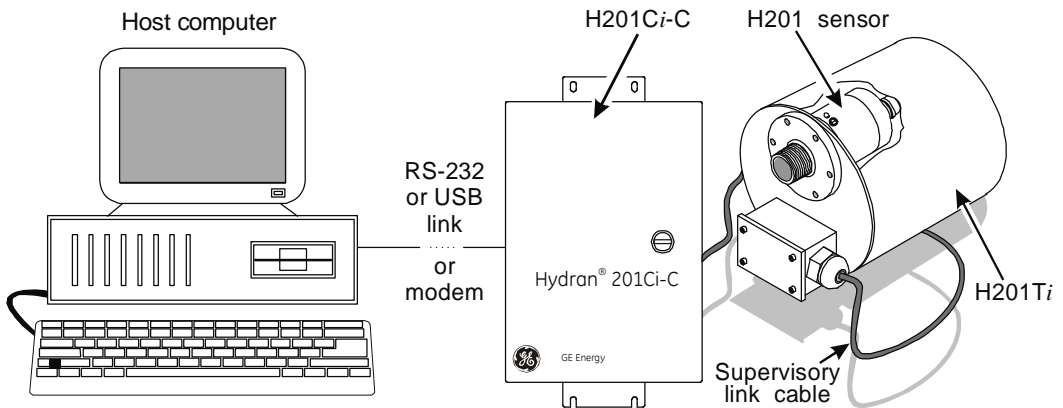

*Figure 3-1 - Typical Configuration of a Hydran 201*i* System*

3.1.1 Features

The Hydran 201*Ci*-C is meant specifically to interface a network of up to 128 Hydran 201*Ti*'s to a computer via a single RS-232 or USB link, or an optional modem. As opposed to the Hydran 201*Ci*-1 (Section 3.2 on page 3-7), the H201*Ci*-C does not have a display, nor does it provide alarms or analog outputs.

Up to four H201*Ti*'s (typically, a transformer bank [A, B, C] and sometimes an auxiliary) can be connected to each H201*Ci*-C through the isolated supervisory link. A maximum of

32 H201Ci-C's (and/or Hydran 201Ci-1's) can be networked via an RS-485 Local Area Network (LAN).

The H201Ci-C features:

- A digital circuit board to control all communications, including networking.
- A terminal block to connect the ac power supply.
- A terminal block to connect the H201Ci-C and the H201Ti's with a supervisory link.
- Connectors for the communication cables:
 - RS-232 or USB link toward a host computer or a modem.
 - RS-485 link toward other H201Ci Controllers to establish a network.
- Network and communication management. The H201Ci-C (or any other Hydran 201Ci Controller in a local network) is connected to the host computer with an RS-232 or USB link or a modem (optional) and to each H201Ti with a supervisory link. A maximum of 32 H201Ci Controllers (H201Ci-C and/or H201Ci-1) can be connected together with an RS-485 link to establish a local network that can contain up to 128 H201Ti's. For details on network configurations, see Chapter 9.

3.1.2 Description of the Major Components

An internal view of the Hydran 201Ci-C is presented in Figure 3-2 on page 3-3.

1. *Enclosure:* The H201Ci-C cabinet is rated Type NEMA 4X. With the standard internal heater, the instrument operating temperature ranges from -40 to +55 °C (-40 to +131 °F).
2. *DB-9 Male RS-232 Connector:* This standard DB-9 male serial communications connector, housed in a small connection box, allows easy connection of an external PC.
3. *USB Computer Port Connector, Type B:* This standard USB (type-B) female serial communications connector allows to easily connect a PC.
4. *Electronic Circuit Board:* The circuit board incorporates all the electronic functions of the H201Ci-C: Isolated supervisory link supply, communication ports and modem (optional) management, enclosure heater control, and ac supply voltage selector.

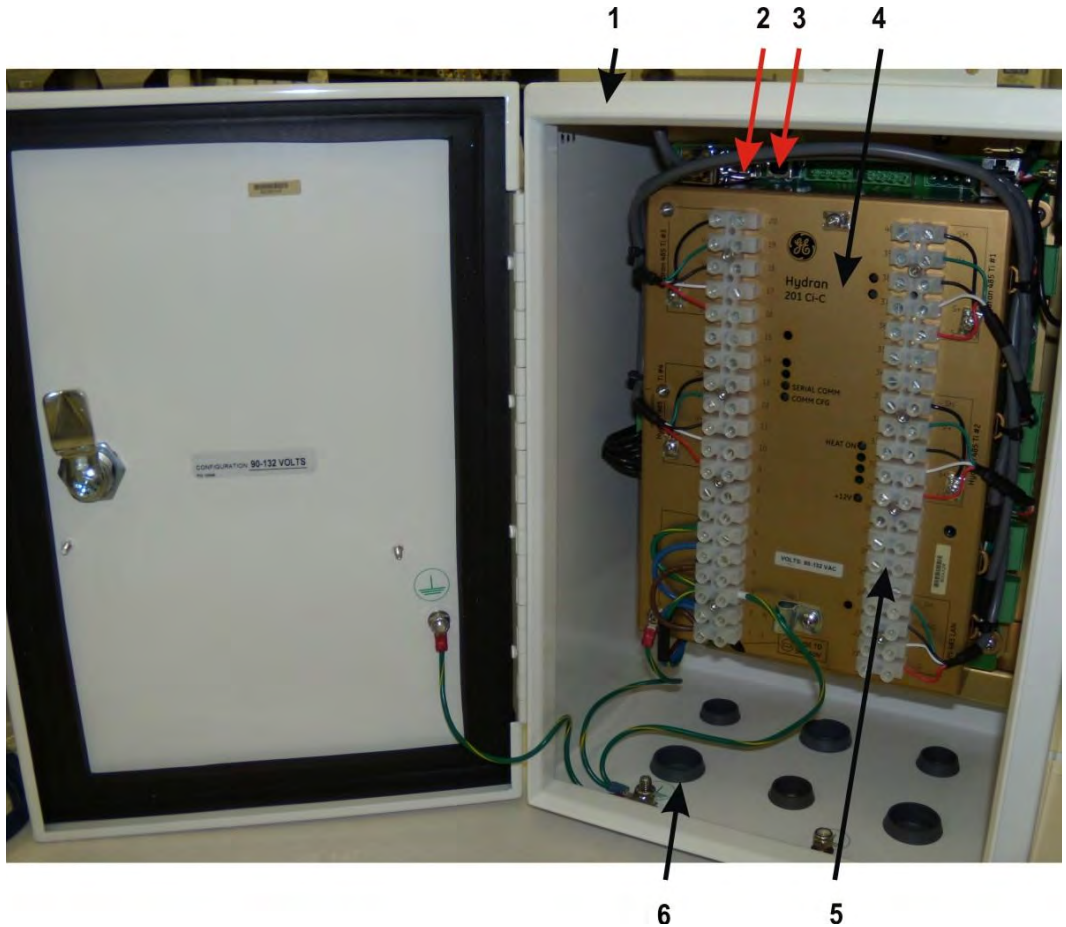

Figure 3-2 - Internal View of the Hydran 201Ci-C

5. *Main Terminal Block:* The ac power supply, the supervisory link cables and the RS-485 LAN are connected to this 40-screw terminal block. For wiring details, see Table D-8 on page D-5.

WARNING

ELECTRICAL SHOCK HAZARD. Voltage of 115 or 230 Vac is present on several connecting screws of this terminal block.

6. *Perforated Openings:* Six perforated openings are present in the bottom plate of the cabinet for wiring purposes. Three holes have a 0.75-in diameter and three holes have a 0.5-in diameter.

3.1.3 Description of the Circuit Board

The circuit board of the H201Ci-C is presented in Figure 3-3 on page 3-5.

7. *RS-232 Computer Port Connector, DB-9 Male (J10)*: This standard connector is used to interface the H201Ci-C directly to a PC or to a smart modem. For wiring details, see Table D-10 on page D-8. The USB computer port (J16) is also available (item 8 in Figure 3-3 on page 3-5).
8. *USB Computer Port Connector, Type B (J16)*: This connector is available to interface the H201Ci-C directly to a PC or to a smart modem. The RS-232 computer port (J10) can also be used (item 7 in Figure 3-3 on page 3-5).
9. *5-Vdc and 12-Vdc Power Supply Connector, 4 Pins (J6)*: This power source can be used for optional equipment. Each line is protected with a 1.35-A fuse.
10. *Optional Modem Connector, 4 Pins (J9)*: This connector is used to interface the H201Ci-C with a modem. The telephone line should be connected here. For more detail, refer to the modem procedure located in the **English/Procedures** folder of the Hydran 201i System installation CD.
11. *RS-485 LAN Connector, 3 Pins (J11)*: To set up a H201Ti network, the H201Ci-C's (and/or H201Ci-1's) are daisy-chained together into an RS-485 Local Area Network (LAN).
12. *Supervisory Link Connector to Termination Board No. 1, 4 Pins (J15)*: An isolated supervisory link cable coming from a H201Ti (through the termination board) is connected here. The link cable carries serial data (communications) and isolated link supply (+15 Vdc, from the H201Ci-C).

Note: The TDM pulse signal from the H201Ti (which uses a third pair when the supervisory link is connected to a H201Ci-1) is not used by the H201Ci-C. The TDM pulse signal only carries analog data and relay status, and it is not required for communications and networking functions.

13. *Heater Indicator, Yellow (DS8)*: This LED indicator is lit when the enclosure heater is On. The enclosure temperature is controlled and the heater periodically turns on and off to maintain the temperature near 25 °C (77 °F).

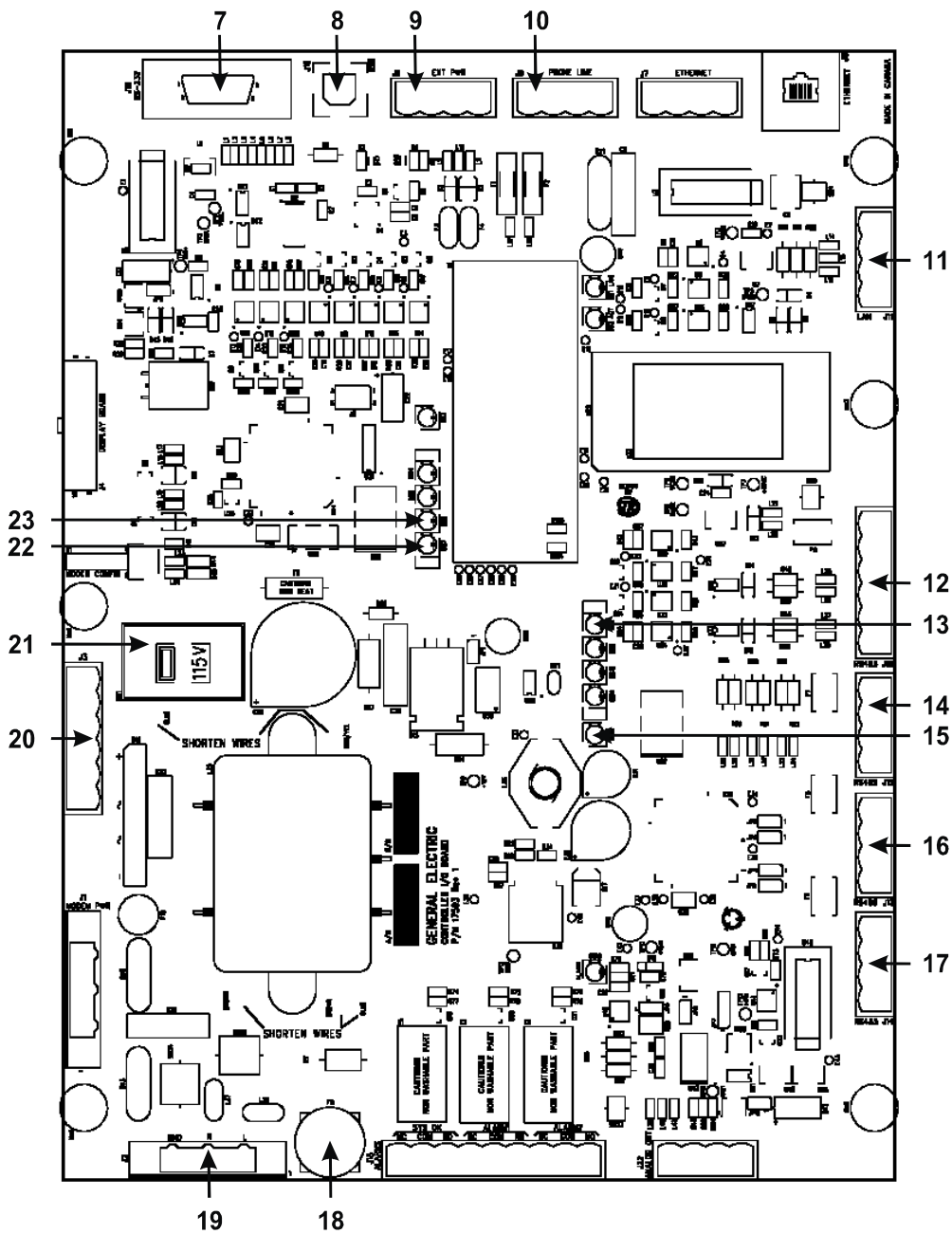

Figure 3-3 - Circuit Board of the Hydran 201Ci-C

14. *Supervisory Link Connector to Termination Board No. 2, 4 Pins (J12)*: See item 12 on page 3-4.
15. *Supervisory Link Supply Indicator, Green (DS12)*: This LED indicator is lit when the supervisory link power supply is On.
16. *Supervisory Link Connector to Termination Board No. 3, 4 Pins (J13)*: See item 12 on page 3-4.
17. *Supervisory Link Connector to Termination Board No. 4, 4 Pins (J14)*: See item 12 on page 3-4.
18. *ac Supply Fuses (F11)*: There is one fuse holder for standard 5 x 20 mm fuses (the rating can be found in Section 13.5 on page 13-7).
19. *ac Supply Connector, 3 Pins (J2)*: The ac line is factory-wired from the ac terminal block to this connector.
20. *Heater Connector, 6 Pins (J3)*: The enclosure heater is factory-wired to the connector J3. It consists of two 50-W resistors located under the support bracket of the electronic circuit board.
21. *Voltage Selector Switch (SW1)*: For wiring details, see Table D-9 on page D-7. This selector is used to choose between the following:
 - 115 V, corresponding to a 90–132 Vac range from 47 to 63 Hz
 - 230 V, corresponding to a 180–264 Vac range from 47 to 63 Hz
22. *Configuration Communication Status Indicator, Yellow (DS7)*: This LED, only used for programming purposes at the factory, indicates there is a configuration of the unit through one of the serial ports. It flickers as data bits pass through the H201Ci-C, whatever the direction and the port (RS-232, RS-485 LAN, USB or optional modem).
23. *Communication Status Indicator, Yellow (DS6)*: This LED indicates that serial communication activity is present. It flickers as data bits pass through the H201Ci-C, whatever the direction and the port (RS-232, RS-485 LAN, USB or supervisory link).

3.1.4 Additional Information

To obtain more information on the Hydran 201Ci-C, please consult the following parts of this manual:

- Before the installation: See Chapter 5.
- Installation: See Chapter 7.
- Communications and networking: See Chapter 9.
- Operation: See Chapter 11.
- Troubleshooting: See Chapter 12.
- Maintenance: See Chapter 13.
- Technical specifications: See Section A.2 on page A-4.
- Mechanical drawing: See Section B.2 on page B-5.
- Functional block diagram: See Section C.2 on page C-2.
- Terminal blocks and connectors: See Section D.2 on page D-5.

3.2 HYDRAN 201Ci-1 ONE-CHANNEL CONTROLLER

Figure 3-4 on page 3-8 shows a Hydran 201R Model *i*. It consists of two components:

- The Hydran 201Ci-1 One-Channel Controller, which is described in detail in Section 3.2 on page 3-7
- The Hydran 201Ti Intelligent Transmitter, already described in Chapter 2

3.2.1 Features

The Hydran 201Ci-1 is designed to supervise one Hydran 201Ti and be used as an interface between this H201Ti and a host computer.

The H201Ci-1 features:

- A numerical display that indicates the dissolved gases-in-oil level in parts per million (ppm), measured by the connected H201Ti.
- Two gas alarm contacts (High and High-High).
- One fail alarm contact.
- Two illuminated push-buttons (alarm indicators) mounted on the door.
- One isolated, analog 4–20 mA output.
- A digital/analog circuit that controls all communications and also the display, analog outputs and alarm functions.

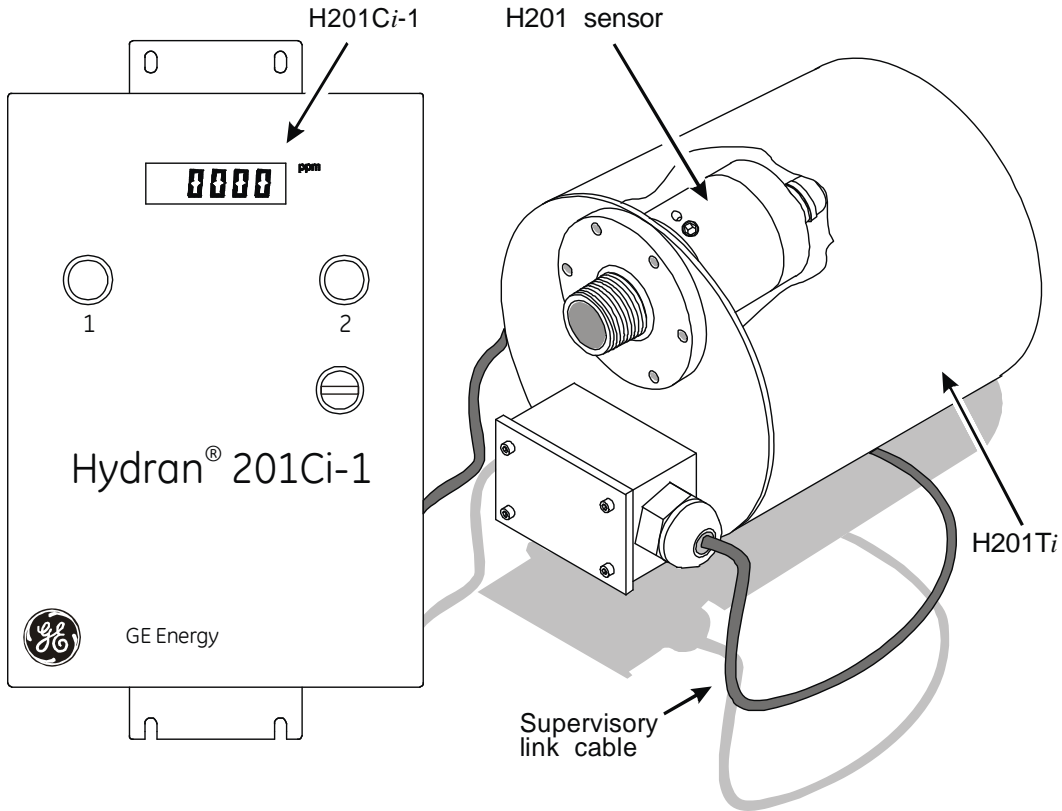

Figure 3-4 - Hydran 201R Model i

- Network and communication management. The H201Ci-1 (or any other Hydran 201Ci Controller in a local network) is connected to the host computer with an RS-232 or USB link or a modem (optional) and to each H201Ti with a supervisory link. A maximum of 32 H201Ci Controllers (H201Ci-C and/or H201Ci-1) can be connected together with an RS-485 link to establish a local network that can contain up to 128 H201Ti's. For details on network configurations, see Chapter 9.
- A terminal block to connect the following components:
 - ac power supply
 - Supervisory link between the H201Ci-1 and the H201Ti
 - RS-485 link toward other H201Ci controllers to establish a network
 - Alarm contacts (High, High-High and fail)
 - Isolated, analog output
- Connectors for the RS-232 or USB link toward a host computer.

3.2.2 Description of the Major Components

An external view of the H201Ci-1 is presented in Figure 3-5 on page 3-9.



Figure 3-5 - External View of the Hydran 201Ci-1

1. *Digital Display:* The LED digital read-out displays the content of combustible gas in the oil. The standard range of the H201Ci-1 display is 0 to 1,999 ppm (volume/volume). When the H201Ci-1 is linked to a Hydran 201Ti, the display reflects the actual H201Ti's reading. The display blanks when a system fault occurs at the H201Ti level or in the H201Ci-1 itself.

2. *Door-Mounted Alarm Indicators and Push-buttons:* The two illuminated push-buttons are mounted on the cabinet door of the instrument. Each local indicator latches on when the corresponding gas alarm relay is energized. The indicator remains on when the alarm relay turns off and it must be cleared (or “acknowledged”) by pressing the illuminated indicator. The indicator clears only when the corresponding gas alarm relay has de-energized.
3. *Enclosure:* The H201Ci-1 cabinet is rated Type NEMA 4X. With the standard internal heater, the instrument operating temperature ranges from -40 to +55 °C (-40 to +131 °F).

An internal view of the H201Ci-1 is presented in Figure 3-6 on page 3-11.

4. *Digital Display Circuit Board Cover:* This cover protects the display circuit board, which includes the digital voltmeter and the connections of the two push-buttons.
5. *Electronic Circuit Board:* The circuit board incorporates all the electronic functions of the H201Ci-1: H201Ti TDM pulse decoder, alarm relay drivers, configurable analog output amplifiers, display signal conditioning, supervisory link supply, communication ports and modem (optional) management, enclosure heater control, and ac supply voltage selector. See Section C.3 on page C-3 for a simplified block diagram of the circuit.
6. *Main Terminal Block:* The ac power supply, the analog output, the three alarm relays (Alarm 1 = Gas High, Alarm 2 = Gas High-High, and System OK), the supervisory link cables and the RS-485 LAN are connected to this 40-screw terminal block. For wiring details, see Table D-11 on page D-8.

WARNING

ELECTRICAL SHOCK HAZARD. Voltage of 115 or 230 Vac is present on several connecting screws of this terminal block.

3.2.3 Description of the Circuit Board

The circuit board of the Hydran 201Ci-1 is presented in Figure 3-7 on page 3-12.

7. *RS-232 Computer Port Connector, DB-9 Male (J10):* This standard connector is used to interface the H201Ci-1 directly to a PC or to a smart modem. For wiring details, see Table D-13 on page D-11. The J16 USB computer port (item 8 in Figure 3-7 on page 3-12) is also available.

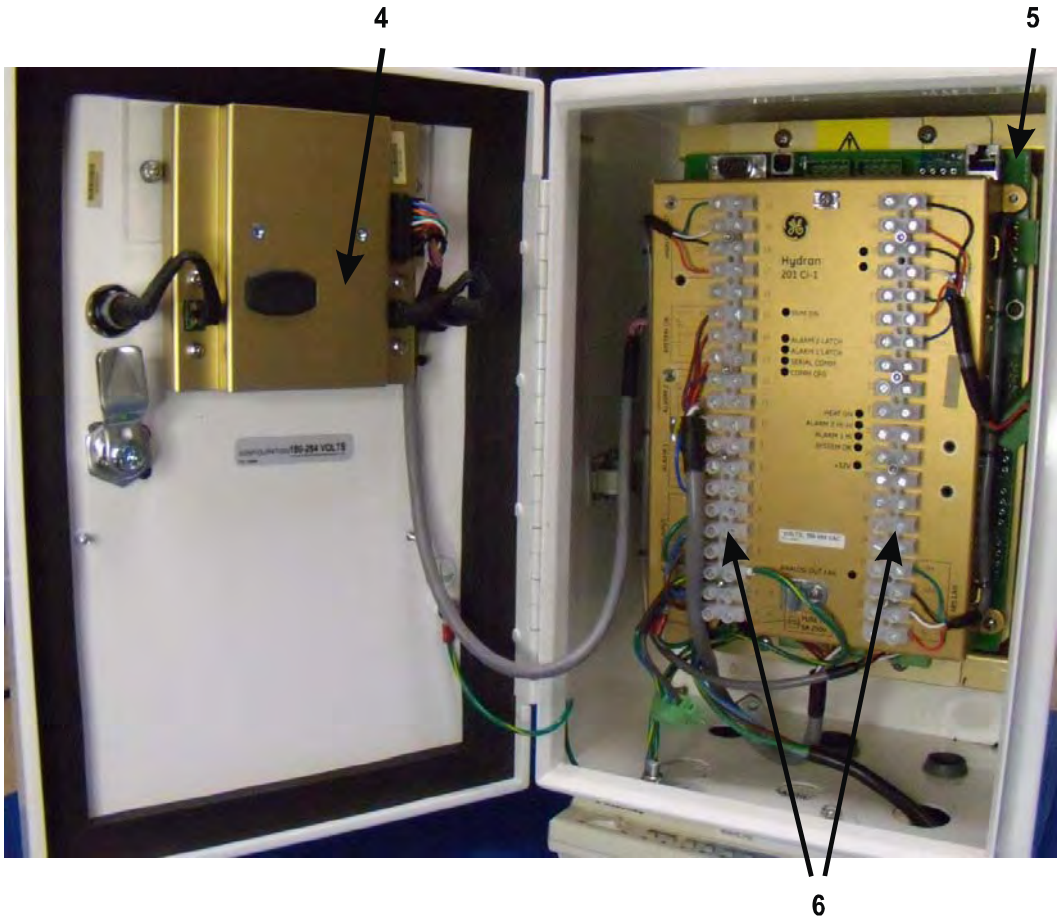

Figure 3-6 - Internal View of the Hydran 201Ci-1

8. *USB Computer Port Connector, Type B (J16)*: This connector is available to interface the H201Ci-1 directly to a PC or to a smart modem. The RS-232 computer port (J10) can also be used (item 7 in Figure 3-7 on page 3-12).
9. *5-Vdc and 12-Vdc Power Supply Connector, 4 Pins (J6)*: This power source can be used for optional equipment. Each line is protected with a 1.35-A fuse.

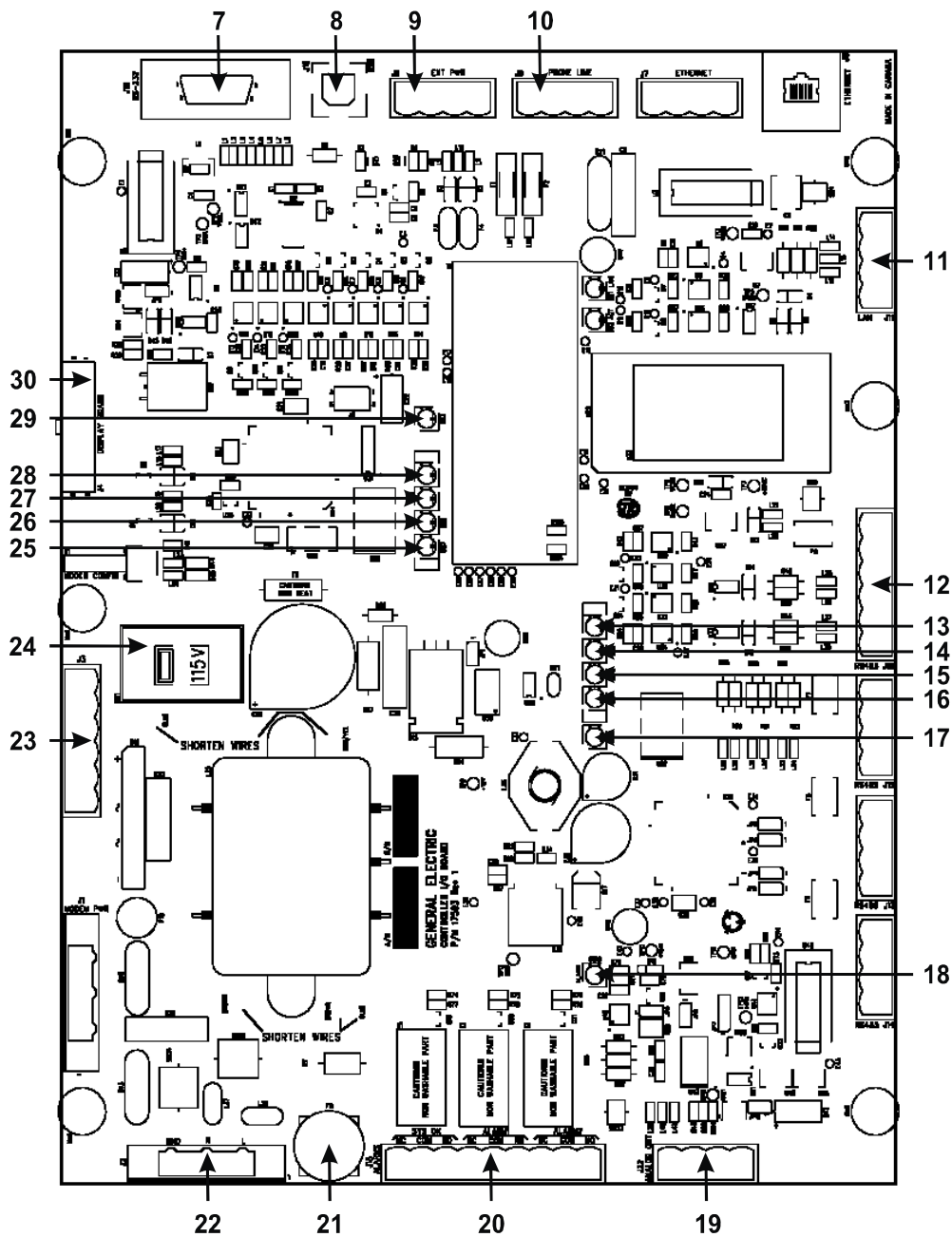

Figure 3-7 - Circuit Board of the Hydran 201Ci-1

10. *Optional Modem Connector, 4 Pins (J9)*: This connector is used to interface the H201Ci-1 with a modem. The telephone line should be connected here. For more detail, refer to the modem procedure located in the **English/Procedures** folder of the Hydran 201i System installation CD.
11. *RS-485 LAN Connector, 3 Pins (J11)*: To set up a H201Ti network, the H201Ci-1's (and/or H201Ci-C's) are daisy-chained together into an RS-485 Local Area Network (LAN).
12. *Supervisory Link Connector, 6 Pins (J15)*: The isolated supervisory link cable coming from the H201Ti is connected here. The link cable carries the TDM pulse signal (analog data and relay status), serial data (communications) and isolated loop supply (+15 Vdc, from the H201Ci-1).
13. *Heater Indicator, Yellow (DS8)*: This LED indicator is lit when the enclosure heater is on. The enclosure temperature is controlled and the heater periodically turns on and off to maintain the temperature near 25 °C (77 °F).
14. *Alarm 2 (Gas High-High) Indicator, Yellow (DS9)*: This LED indicator is lit when a Gas High-High alarm condition (level, hourly trend or daily trend) is detected by the H201Ti. It turns off when the condition is cleared. The H201Ci-1's Gas High-High relay tracks the equivalent relay in the H201Ti.
15. *Alarm 1 (Gas High) Indicator, Yellow (DS10)*: This LED indicator is lit when a Gas High alarm condition (level, hourly trend or daily trend) is detected by the H201Ti. It turns off when the condition is cleared. The H201Ci-1's Gas High relay tracks the equivalent relay in the H201Ti.
16. *System OK Indicator, Yellow (DS11)*: This LED indicator is lit when there is no system fault. It turns off when a system fault is detected by the H201Ti, or when the link is broken between the H201Ti and the H201Ci-1, or if there is an ac power loss in the H201Ti or the H201Ci-1. The H201Ci-1's System Fail relay is de-energized when the System OK indicator is off.
17. *Supervisory Link Supply Indicator, Green (DS12)*: This LED indicator is lit when the supervisory link power supply is On.
18. *Analog Out Failure Indicator, Red-Orange (DS13)*: This LED indicator is lit when the analog output is not working properly, is unplugged or is not used.

19. *Analog Outputs (J22)*: This connector is factory-wired to the terminal block between pins 17 and 20.
20. *Alarm Contacts Connector, 9 Pins (J18)*: The Gas High, Gas High-High and System OK alarm relays are factory-wired from this connector to the terminal block between pins 7 and 15. A three-wire type-C (Normally Open + Normally Closed + Common) set of contacts is available for each alarm.

Note: The System OK alarm relay is normally energized. When a system fault occurs, it de-energizes the relay. Thus, the Normally Open (NO) contact actually opens on system failure or power loss. See Chapter 10 for a description of the Hydran alarms.

21. *ac Supply Fuses (F11)*: There is one fuse holder for standard 5 x 20 mm fuses (the rating can be found in Section 13.5 on page 13-7).
22. *ac Supply Connector, 3 Pins (J2)*: The ac line is factory-wired from the ac terminal block to this connector.
23. *Heater Connector, 6 Pins (J3)*: The enclosure heater is factory-wired to the connector J3. It consists of two 50-W resistors located under the support bracket of the electronic circuit board.
24. *Voltage Selector Switch (SW1)*: For wiring details, see Table D-12 on page D-11. This selector is used to choose between the following:
 - 115 V, corresponding to a 90–132 Vac range from 47 to 63 Hz
 - 230 V, corresponding to a 180–264 Vac range from 47 to 63 Hz
25. *Configuration Communication Status Indicator, Yellow (DS7)*: This LED, only used for programming purposes at the factory, indicates there is a configuration of the unit through one of the serial ports. It flickers as data bits pass through the H201Ci-1, whatever the direction and the port (RS-232, RS-485 LAN, USB or optional modem).
26. *Communication Status Indicator, Yellow (DS6)*: This LED indicates that serial communication activity is present. It flickers as data bits pass through the H201Ci-1, whatever the direction and the port (RS-232, RS-485 LAN, USB or supervisory link).

27. *Alarm 1 High Latch Indicator, Red-Orange (DS5)*: This LED indicates that the operator did not acknowledge the alarm 1 (Gas High). It is impossible to acknowledge the alarm if it is still active.
28. *Alarm 2 High-High Latch Indicator, Red-Orange (DS4)*: This LED indicates that the operator did not acknowledge the alarm 2 (Gas High-High). It is impossible to acknowledge the alarm if it is still active.
29. *Digital Voltmeter Indicator, Yellow (DS3)*: This LED indicates that the digital voltmeter on the front panel is On. This means that the H201Ci-1 has a valid TDM (Time Division Multiplexing) signal from the H201Ti.
30. *Display Board Connector, 16 Pins (J4)*: This connector is factory-wired to the display board located on the door. This is the cable used for communication between the controller board and the display board.

3.2.4 Additional Information

To obtain more information on the Hydran 201Ci-1, please consult the following parts of this manual:

- Before the installation: See Chapter 5.
- Installation: See Chapter 8.
- Communications and networking: See Chapter 9.
- Alarms: See Chapter 10.
- Operation: See Chapter 11.
- Troubleshooting: See Chapter 12.
- Maintenance: See Chapter 13.
- Technical specifications: See Section A.3 on page A-6.
- Mechanical drawing: See Section B.3 on page B-6.
- Functional block diagram: See Section C.3 on page C-3.
- Terminal blocks and connectors: See Section D.3 on page D-8.

PAGE LEFT INTENTIONALLY BLANK

Hydran 201Ti's Displays and Menus

Note: It is recommended to use the Hydran Host software rather than the H201Ti's user interface (keypad and display). See the Hydran Host Software Manual.

All parameters and commands that can be accessed with the H201Ti's user interface can also be accessed with the Hydran Host software, except for the analog inputs/outputs calibration and the communication parameters. The first power-up (see Section 4.2.5 on page 4-6) must also be performed using the H201Ti's keypad.

4.1 USER INTERFACE

The Hydran 201Ti's user interface is located on the front of the CPU module (item 4 in Figure 2-2 on page 2-5). It consists of the following (see Figure 4-1 on page 4-2):

- An alphanumeric LCD display, consisting of two lines of 16 characters. It requires no manual contrast adjustment and is equipped with temperature compensation. When the H201Ti is closed, the display remains visible through a window in the aluminum cover.

Note: Make a shadow over the display and observe the backlighting. Although it appears dim in daylight, the backlight allows easy reading of the display at night. The contrast of this thermally-compensated display is set automatically; it can thus operate over the full temperature range of the H201Ti and is perfectly readable under all ambient lighting conditions. At low temperatures, the LCD display might not be legible, but all other functionalities are fully operational.

- A six-key keypad (see Section 4.3 on page 4-7), also designed to function under an extremely wide temperature range.

The H201Ti's user interface has three main functions:

- *First priority:* To display all unacknowledged alarm messages requiring an action from the user. This task corresponds to the Unacknowledged Alarms mode (Section 4.2.1 on page 4-3).



Figure 4-1 - Hydran 201Ti's User Interface

- *Second priority:* To execute commands requested through the keypad and to display the parameters from the Main Menu and the Extended Menu. These tasks correspond to the Menu Navigation mode (Section 4.2.3 on page 4-5) and the Parameter Modification mode (Section 4.2.4 on page 4-6).

- *Third priority*: If all active alarms have been acknowledged and if the keypad is not used, to display a list of messages at a rate of one message every five seconds. This task corresponds to the Main Display mode (Section 4.2.2 on page 4-4).

4.2 USER INTERFACE OPERATING MODES

The Hydran 201Ti's user interface uses five operating modes:

- Unacknowledged Alarms mode (Section 4.2.1 on page 4-3): The H201Ti displays flashing messages of unacknowledged alarms. The user acknowledges an alarm by pressing the **ENTER** key while the corresponding alarm message is displayed on the display.
- Main Display mode (Section 4.2.2 on page 4-4): In this basic, unattended operating mode (if all active alarms have been acknowledged and if the keypad is not used), the H201Ti displays a list of four messages:
 - Gas level (in ppm)
 - Hourly trend (in ppm/x hours)
 - Daily trend (in ppm/x days)
 - Date and time
- Menu Navigation mode (Section 4.2.3 on page 4-5): This mode gives access to the H201Ti's parameters and commands.
- Parameter Modification mode (Section 4.2.4 on page 4-6): This mode is used with the Menu Navigation mode to set the H201Ti's parameters (alarm levels, date and time, etc.).
- Power-up mode (Section 4.2.5 on page 4-6): This mode is used only during the H201Ti's power-up. Three sequences can occur:
 - Normal power-up: Occurs if the ac power supply has been off for more than five minutes.
 - Short power-up: Occurs if the ac power supply has been off for less than five minutes.
 - First power-up: Occurs if the H201Ti's battery has been disconnected and reconnected.

4.2.1 Unacknowledged Alarms Mode

An alarm condition exists when a variable (such as gas level, gas trend or sensor temperature) has exceeded the predetermined limits (“alarm setting”). Alarms are explained in detail in Chapter 10; all alarm messages are given in Section 12.1 on page 12-1.

The unacknowledged alarm messages are always displayed in priority. When an alarm occurs, the Main Display mode is immediately replaced by the Unacknowledged Alarms mode. If two or more unacknowledged alarms are present, the display scrolls through their messages at the rate of one every five seconds.

The user acknowledges each alarm by pressing the **ENTER** key for each alarm message. The flashing messages are then removed from the list one at a time. The H201Ti returns to the Main Display mode when the user has acknowledged all alarms. Acknowledged alarms that are still active are shown as non-flashing messages in the Main Display list (see Section 4.2.2 on page 4-4). When an alarm condition disappears, this message is removed from the Main Display list.

Almost all alarm messages are displayed as follows, whether the alarm is unacknowledged (flashing) or not (alarm condition still present):

- The top line displays the alarm message (the name of the parameter that triggered the alarm) followed by the alarm state: LL (Low-Low), L (Low), H (High) or HH (High-High).
- The bottom line displays the parameter's alarm set point (not the measured value). The LL, L, H and HH alarm set points can all be adjusted and turned off.

In this first example, the actual display is on the left and the comments are on the right:

Gas HH	Gas High-High alarm
300 PPM	Gas level above 300 ppm

4.2.2 Main Display Mode

When the H201Ti is operating properly (no unacknowledged alarms, keypad unused), the messages shown in Table 4-1 on page 4-5 are displayed at the rate of one every five seconds.

Note: The display shows the alarm setting that was exceeded, NOT the actual value of the variable in alarm.

Table 4-1 - Messages Displayed in the Main Display Mode

Display	Description
Alarm message (Alarm set point)	Displayed only if an alarm occurred, if it was acknowledged and if the alarm condition is still present. See Section 4.2.1 on page 4-3.
GasLevel xxx PPM	<ul style="list-style-type: none"> Gas level measured by the Hydran 201 sensor Range: 0 to 2,000 ppm Initial value^b: 0 to 20 ppm
HourlyTrend +xx / 24 h	<ul style="list-style-type: none"> Variation in ppm of the gas level for a period in hours Period adjustable from 1 to 99 hours Initial value^a: 0 ppm/24 hours (default value of the period)
DailyTrend +xx / 30 d	<ul style="list-style-type: none"> Variation in ppm of the gas level for a period in days Period adjustable from 1 to 99 days Initial value^a: 0 ppm/30 days (default value of the period)
(Date) ^a (Time)	Date (year-month-day format) Time (24-hour format)

a. The H201Ti's clock is set at the factory. Local time may differ from the displayed time; to set it, see Section 6.2.3 on page 6-8.

b. Sensor exposed to air; for example, during the initial verification or the installation.

4.2.3 Menu Navigation Mode

The Menu Navigation mode is used to access the Main Menu or the Extended Menu, and thus to all H201Ti's parameters and commands without requiring the use of a host computer.

- The Main Menu gives access to the *most frequently used* parameters and commands.
- The Extended Menu gives access to *all* parameters and commands.

Note: The H201Ti automatically returns to the Main Display mode if the keypad is not used for five minutes.

Each submenu of the Main Menu and Extended Menu is described in detail in Section 4.5 on page 4-10.

4.2.4 Parameter Modification Mode

The Parameter Modification mode is accessed by pressing the **CHANGE** key when an adjustable parameter is displayed. In the Main Menu, a password is then requested; in the Extended Menu, a password is requested only for parameters requiring password No. 2 (because password No. 1 has already been entered to access the Extended Menu). For details on passwords, see Section 4.4 on page 4-9.

The Parameter Modification mode is indicated with a colon displayed on the bottom line, at the left of the numerical value or choice to being modified. The value of the parameter can then be changed using the **UP** and **DOWN** keys; the modification is validated with **ENTER**.

4.2.5 Power-up Mode

Depending on start-up conditions, the H201Ti executes one of the following sequences:

- Normal power-up (power-off longer than five minutes): See Section 4.2.5.1 on page 4-6.
- Short power-up (power-off shorter than five minutes): See Section 4.2.5.2 on page 4-7.
- First power-up (after reconnection of battery): See Section 4.2.5.3 on page 4-7.

4.2.5.1 Normal Power-up (Power-off Longer Than Five Minutes)

This sequence begins with a self-test sequence that lasts approximately 40 seconds; then the Main Display mode is shown on the display. Table 4-2 on page 4-6 details the self-test sequence.

Table 4-2 - Self-Test Sequence During the Normal Power-up

Display	Internal Action
POWER DOWN	Is displayed for one second
SYSTEM HALTED	
System;Initialization	Verifies and prepares the hardware
ABCDEFGHIJKLMNQP;QR...	Allows for a visual verification of the display
TestingRam	Verifies data memory
Testing Histo Ram	Verifies historic data memory
Testing RTC	Verifies the real-time clock

4.2.5.2 Short Power-up (Power-off Shorter Than Five Minutes)

In this sequence, the self-test is not executed. After the message **System;Initialization**, the Main Display mode is immediately displayed.

4.2.5.3 First Power-up (After Reconnection of Battery)

In this sequence, the H201Ti requests the values listed in Table 4-3 on page 4-7 before executing the self-test sequence. The Main Display mode is then displayed (the H201Ti will not be in service until these values are entered).

Table 4-3 - Values Requested During the First Power-up Sequence

Display	Data Entry	Action
Enter Date&Time	Press ENTER	Start the dialog
Year	(Year)	Enter the requested value
Month	(Month)	
Day	(Day)	
Hour	(Hour)	
Minute	(Minute)	
PowerStat. ID^a	0	<i>Absolutely</i> enter a number (1 to 9999)
H201Ti ID^a		<i>Absolutely</i> enter a number (1 to 254)

a. For details on these parameters, see Section 4.5.6.5 on page 4-23.

Note: The dialog of the first power-up can only be performed using the H201Ti's keypad, not the Hydran Host software.

4.3 USING THE KEYPAD'S KEYS ACCORDING TO EACH MODE

The Hydran 201Ti's keypad is shown in Figure 4-2 on page 4-8. Table 4-4 on page 4-8 summarizes the functions of the keys according to the operating modes.

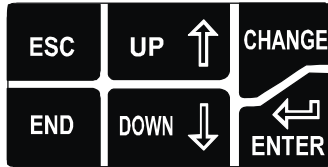

Figure 4-2 - Hydran 201Ti's Keypad

Table 4-4 - Functions of the Keypad's Keys According to the Operating Modes

Key	Unacknowledged Alarms Mode	Main Display Mode	Menu Navigation Mode	Parameter Modification Mode
ENTER	Acknowledges alarms	Enters Menu Navigation mode	Selects a submenu or an item	Validates a new value
CHANGE	Scrolls forward one step in unacknowledged alarms	Scrolls forward one step in Main Display list	When allowed, enters Parameter Modification mode; otherwise no effect	Toggles choices between on and off; no effect on numerical value
DOWN			Scrolls forward in list	Decrements a numerical value ^a
UP			Scrolls backward in list	Increments a numerical value ^a
ESC			Returns to the preceding level	Quits the mode and cancels current modification
END			Returns to Main Display mode	

a. Press and hold the **UP** or **DOWN** key for more than one second to increase or decrease steadily the displayed value; hold it for more than three seconds to accelerate the rate of increase or decrease.

4.4 PASSWORDS

The H201Ti's user interface is protected by passwords. Entering a password is necessary to modify parameters or to access specific sections of menus:

- Password No. 1 (first level): This password is **1253**. It allows the user to modify almost all the H201Ti's parameters.
- Password No. 2 (second level): This password is **1231**. It allows the user to access the following items:
 - The **Calibration** submenu (to calibrate the H201Ti)
 - The **NewSensor** submenu (to enter the parameters of the Hydran 201 sensor)
 - The three **Clear** commands in the **History** submenu (to erase the historic data files)

Password protection prevents accidental or unauthorized changes of the H201Ti's parameters. The passwords should be divulged to authorized personnel only, particularly password No. 2. The passwords are common to all H201Ti's and cannot be changed.

Note: Passwords used in the Hydran Host software are independent from those entered via the H201Ti's keypad, and they can be changed (see the Hydran Host Software Manual).

When the H201Ti requests a password, one of the following two messages is displayed:

- **Password 1?**
:1247
- **Password 2?**
:1247

Use the **UP** or **DOWN** key (see Figure 4-2 on page 4-8) to increment or decrement the displayed value, and press **ENTER** to accept the value. The user is now authorized to change the parameters until he quits the Menu Navigation mode. No password will be requested again unless a higher level password is required.

Note: All modifications are recorded in the historic data file Events (see Section 4.5.1 on page 4-12).

4.5 MAIN AND EXTENDED MENU

The Main Menu gives access to the H201Ti's *most frequently used* parameters and commands. The Extended Menu gives access to *all* parameters and commands (including all parameters and commands from the Main Menu).

Note: Even if the H201Ti's menu system gives access to all its operation parameters, using a host computer and General Electric Canada's Hydran Host software simplifies the tasks. For more information, see the Hydran Host Software Manual.

Table 4-5 on page 4-10 summarizes the functions of each submenu of the H201Ti's embedded software.

Table 4-5 - Functions of the Submenus of the H201Ti's Embedded Software

Submenu	Functions
History^a	<ul style="list-style-type: none"> • To consult the four historic data files: <ul style="list-style-type: none"> – Events (recording at the time of events; example: alarms) – Short Term (recording at fixed logging rate; example: every 15 minutes) – Long Term (recording at fixed logging rates; example: every 6 hours) – Service (recording at the time of the semimonthly, automatic sensor test) • To set the logging rate of these files. • To clear the content of these files.
Gas^a	<ul style="list-style-type: none"> • To set the parameters of the conditions that trigger the gas alarm: High and High-High gas level, hourly trend and daily trend. • To set the parameters of the conditions that trigger the fail alarm: Low and Low-Low gas level, hourly trend and daily trend.

Submenu	Functions
Temperature^a	<ul style="list-style-type: none"> • To read the current temperature of the Hydran 201 sensor. • To set the parameters of the sensor temperature alarm. • To adjust the set point of the sensor temperature. • To set periods A and B. • To read the actual set point, heating power and temperature of the heating plate. • To set the parameters of the dynamic oil sampling system.
Service^a	<ul style="list-style-type: none"> • To read the value of the H201 sensor parameters. • To test the H201 sensor operation. • To read the battery voltage. • To set the parameters of the battery alarm. • To read the service data of the H201 sensor.
Date&Time (Extended Menu only)	<ul style="list-style-type: none"> • To set the date. • To set the time.
Communication (Extended Menu only)	<ul style="list-style-type: none"> • To select the communication channel: RS-232 link or supervisory link. • To set the communication parameters.
Relays/Analog (Extended Menu only)	<ul style="list-style-type: none"> • To read the state of the alarm relays: On or Off. • To set the operation mode of the three alarm relays^b. • To select the triggering conditions of the fail alarm (FaultTrig). • To read the state of the analog output and TDM signal (in %). • To set the operation mode of the analog output and TDM signal.
NewSensor (Extended Menu only)	<ul style="list-style-type: none"> • To set the H201 sensor parameters. • To install a new H201 sensor.
Calibration (Extended Menu only)	<ul style="list-style-type: none"> • To calibrate the three analog inputs: <ul style="list-style-type: none"> – The H201 sensor signal – The H201 sensor temperature – The heating plate temperature • To calibrate the analog output.

a. These submenus can be accessed from both Menus (Main and Extended); except the **Service** submenu, they contain more parameters and commands in the Extended Menu.

b. There are four modes: **Latch**, **Normal**, **Force ON** and **Force OFF**.

The following Sections describe the parameters and commands of each submenu.

4.5.1 History Submenu

The **History** submenu allows the user to:

- Consult the four historic data files:
 - Events (recording at the time of events; example: alarms)
 - Short Term (recording at fixed logging rate; example: every 15 minutes)
 - Long Term (recording at fixed logging rates; example: every 6 hours)
 - Service (recording at the time of the semimonthly, automatic sensor test)
- Set the logging rate of these files.
- Clear the content of these files.

4.5.1.1 Events History

When an event occurs, the date and time of occurrence, an event message and ten variables are stored in historic data file Events. Its capacity is 500 recordings; when the file is full and a new recording occurs, the oldest recording is deleted (first in, first out method). All event messages and their description are provided in Appendix E.

The following events are recorded:

- An alarm is triggered.
- An alarm is acknowledged by a user.
- An alarm is cancelled (the alarm condition has disappeared).
- A parameter is changed by a user.
- A new Hydran 201 sensor is installed.
- The H201Ti is calibrated.
- A power-up or a power-down occurs.
- The H201Ti is put in service (first power-up).
- The self-test sequence has failed during power-up.
- The microprocessor is reset by the internal watchdog.

Navigation is performed as follows:

- From **History;Events**, press **ENTER** to read the date and time of the last event recorded in the historic data file Events.
- Press **UP** or **DOWN** to read the date and time of previous or next events.

- Press **ENTER** to read a message describing the event that occurred at the selected date and time.
- Press **ENTER** and **UP** or **DOWN** to read the value of the variables at the time of this event.

The following ten variables are recorded in the historic data files Events (this list is identical for the Short Term and Long Term files):

- **GasLevel**
- **HourlyTrend**
- **HourlyTr Period** (period of the hourly trend)
- **DailyTrend**
- **DailyTr Period** (period of the daily trend)
- **SensorTemp** (temperature of the H201 sensor)
- *Extended Menu only:*
 - **HeaterTemp** (temperature of the heating plate)
 - **HeatPower**
 - **ServiceU** (value of the **ServiceU** variable)
 - **ServiceV** (value of the **ServiceV** variable)

4.5.1.2 Short Term History

At a certain logging rate (adjustable; see Section 4.5.1.5 on page 4-15), the date and time plus ten variables are stored in the historic data file Short Term. Its capacity is 480 recordings; when the file is full and a new recording occurs, the oldest recording is deleted (first in, first out method).

Navigation is performed as follows:

- From **History;ShortTerm**, press **ENTER** to read the date and time of the last event recorded in the historic data file Short Term.
- Press **UP** or **DOWN** to read the date and time of previous or next recordings.
- Press **ENTER** and **UP** or **DOWN** to read the value of the variables at the selected date and time.

The ten variables recorded in the historic data file Short Term are the same as the ones recorded in the Events file (see Section 4.5.1.1 on page 4-12).

4.5.1.3 Long Term History

From one to four times per day (adjustable; see Section 4.5.1.5 on page 4-15), the date and time plus ten variables are stored in the historic data file Long Term. Its capacity is 480 recordings; when the file is full and a new recording occurs, the oldest recording is deleted (first in, first out method).

Navigation in this file is performed the same way than in the historic data file Short Term (see Section 4.5.1.2 on page 4-13).

The ten variables recorded in the historic data file Long Term are the same as the ones recorded in the Events file (see Section 4.5.1.1 on page 4-12).

4.5.1.4 Service History

A semimonthly, automatic test of the Hydran 201 sensor is performed the first and fifteenth days of each month at midnight (fixed logging rate, non adjustable); for each test, the date and time of the test plus seven variables are recorded in the historic data file Service. Its capacity is 120 recordings (five years); when the file is full and a new recording occurs, the oldest recording is deleted (first in, first out method).

Navigation in this file is performed the same way as in the historic data file Short Term (see Section 4.5.1.2 on page 4-13).

The following seven variables are recorded in the Service file:

- **Battery** (voltage of the battery)
- **ServiceL** (value of the **ServiceL** variable)
- **ServiceI** (value of the **ServiceI** variable)
- **ServiceA** (value of the **ServiceA** variable)
- **SensorTemp** (temperature of the H201 sensor)
- **SerialNumber** (serial number of the H201 sensor)
- **GasLevel**

*Note: The **ServiceL**, **ServiceI** and **ServiceA** variables pertain to the H201 sensor automatic test and are reserved to the General Electric Canada Customer Service. A defective H201 sensor immediately triggers the fail alarm (if this alarm condition is on; see the **FaultTrig** parameter in Section 4.5.7.3 on page 4-24).*

4.5.1.5 History Setup (Extended Menu Only)

This function gives access to the logging rate parameters of the Short Term and Long Term historic data files. Once set, the new value will only come into service after the current period is over.

- **ShrtTerm LogRate:** Logging rate for Short Term recordings. The total capacity is 480 recordings. For example:
 - The minimum logging rate of 1 minute provides a capacity of 480 minutes (8 hours).
 - A logging rate of 5 minutes provides a capacity of 40 hours.
 - The default logging rate of 15 minutes provides a capacity of 5 days.
 - A logging rate of 60 minutes provides a capacity of 20 days.
 - The maximum logging rate of 360 minutes (6 hours) provides a capacity of 120 days (4 months).
- **LongTermLog#1, #2, #3 and #4:** Time of first, second, third and fourth Long Term recordings. The total capacity is 480 recordings. For example:
 - 1 recording per day provides a capacity of 480 days (1 year and 4 months).
 - 2 recordings per day provides a capacity of 240 days (8 months).
 - 3 recordings per day provides a capacity of 160 days (5 months).
 - 4 recordings per day provides a capacity of 120 days (4 months).

*Note: **LongTermLog#1** cannot be turned off; however, **LongTermLog#2, #3 and #4** can each be turned off. The logging times must be set in chronological order, **LongTermLog#1** being the first of the day, **LongTermLog#2** preceding **LongTermLog#3**, etc.*

4.5.1.6 Clear Events (Extended Menu Only)

This function is used to delete all data from the historic data file Events. This command requires password No. 2.

4.5.1.7 Clear Short Term (Extended Menu Only)

This function is used to delete all data from the historic data file Short Term. This command requires password No. 2.

4.5.1.8 Clear Long Term (Extended Menu Only)

This function is used to delete all data from the historic data file Long Term. This command requires password No. 2.

4.5.2 Gas Submenu

The **Gas** submenu allows the user to set the parameters of the conditions that trigger:

- The gas alarm: A High or High-High alarm is triggered if an alarm condition (**GasLevel**, **HourlyTrend** or **DailyTrend**) *exceeds* the corresponding High or High-High alarm set point for a period of time greater than the delay.
- The fail alarm: It is triggered if an alarm condition (**GasLevel**, **HourlyTrend** or **DailyTrend**) *is below* the corresponding Low or Low-Low alarm set point for a period of time greater than the delay.

The operation of the alarms is explained in detail in Chapter 10.

4.5.2.1 Gas Level

This function gives access to the gas level High and High-High alarm parameters:

- **GasLevel**: Current reading of gas level, in ppm. Same value as the one shown in the Main Display mode.
- **GasAlr H**: Set point of gas level High alarm.
- **GasAlr HH**: Set point of gas level High-High alarm.
- **GasAlr Delay**: Alarm delay for all gas level alarms' set points.
- **GasAlr L** (Extended Menu only): Set point of gas level Low alarm.
- **GasAlr LL** (Extended Menu only): Set point of gas level Low-Low alarm.

4.5.2.2 Hourly Trend

This function gives access to the hourly trend High and High-High alarm parameters:

- **HourlyTrend**: Current reading of hourly trend, in ppm/x hours. Same value as the one shown in the Main Display mode.
- **HourTrAlr H**: Set point of hourly trend High alarm.
- **HourTrAlr HH**: Set point of hourly trend High-High alarm.
- **HourTrAlr Delay**: Alarm delay for all hourly trend alarms' set points, in % of the period.
- **HourlyTr Period** (Extended Menu only): Period of the hourly trend (number of hours used to calculate the gas level variation).
- **HourTrAlr L** (Extended Menu only): Set point of hourly trend Low alarm.
- **HourTrAlr LL** (Extended Menu only): Set point of hourly trend Low-Low alarm.

4.5.2.3 Daily Trend

This function gives access to the daily trend High and High-High alarm parameters:

- **DailyTrend:** Current reading of daily trend, in ppm/x days. Same value as the one shown in the Main Display mode.
- **DayTrAlr H:** Set point of daily trend High alarm.
- **DayTrAlr HH:** Set point of daily trend High-High alarm.
- **DayTrAlr Delay:** Alarm delay for all daily trend alarms' set points, in % of the period.
- **DailyTr Period** (Extended Menu only): Period of the daily trend (number of days used to calculate the gas level variation).
- **DayTrAlr L** (Extended Menu only): Set point of daily trend Low alarm.
- **DayTrAlr LL** (Extended Menu only): Set point of daily trend Low-Low alarm.

4.5.3 Temperature Submenu

The **Temperature** submenu allows the user to:

- Read the current temperature of the Hydran 201 sensor.
- Set the parameters of the sensor temperature alarm.
- Adjust the set point of the sensor temperature.
- Set the periods A and B.
- Read the actual set point, heating power and temperature of the heating plate.

Note: Temperatures displayed on the H201Ti's display are given in Celsius degrees.

For explanations on the H201Ti's heating system, see Section 2.6 on page 2-14.

The **Temperature** submenu gives access to the following parameters:

- **SensorTemp:** Current temperature of the H201 sensor.
- **STempAlr LL:** Low-Low alarm set point of H201 sensor temperature.
- **STempAlr L:** Low alarm set point of H201 sensor temperature.
- **STempAlr H:** High alarm set point of H201 sensor temperature.
- **STempAlr HH:** High-High alarm set point of H201 sensor temperature.
- **TempoAlr Delay:** Alarm delay for all above set points.
- **Temp SetPoint** (Extended Menu only): Set point of the H201 sensor temperature (average target temperature).

- **SP Span** (Extended Menu only): Temperature variation according to **Temp SetPoint**. For example: the temperature varies between 30 and 40 °C (86 and 104 °F) if **Temp SetPoint** is set to the recommended temperature of 35 °C (95 °F) and **SP Span** to 10 °C (18 °F).
- **Period A** (Extended Menu only): Modulation period of the temperature variation.
- **Period B** (Extended Menu only): Reserved for General Electric Canada's personnel. If the H201Ti is powered up after a power-down longer than five minutes, the **Period B** ceases to affect the gas level fluctuations for two hours, whether its value has changed or not.
- **SP(Actual)** (Extended Menu only): Current temperature set point.
- **HeatPower** (Extended Menu only): Current heating power (in %) of the heating plate.
- **HeaterTemp** (Extended Menu only): Current temperature (in °C) of the heating plate.

4.5.4 Service Submenu

The **Service** submenu allows the user to:

- Read the value of the Hydran 201 sensor parameters.
- Test the H201 sensor operation.
- Read the battery voltage.
- Set the parameters of the battery alarm.
- Read the service data of the H201 sensor.

4.5.4.1 SensorCal Data

This function gives access to the Hydran 201 sensor parameters. Each sensor has its own set of parameter values; the values are indicated on the Test Certificate and Data Sheet supplied with the Hydran 201Ti.

- **SerialNumber**: Serial number of the H201 sensor (engraved under the sensor connector).
- **B, M, N, S, A1, A2, A3, A4, A5** and **A6**: The ten parameters of the H201 sensor in a normalized format (integer numbers).
 - The H201Ti calculates the gas level in ppm by performing two readings: The H201 sensor temperature (provided by the thermistor incorporated in the sensor body) and the sensor output (gas level). The calculation also requires these ten parameters (from **B** to **A6**).
 - These ten parameters characterize the behavior of the H201 sensor by modeling the offset, linearity and sensitivity fluctuations of the sensor according to the temperature.

- **Checksum:** Checksum of the above values. This value is added to the list to avoid erroneous values from being entered.

This submenu does not allow to modify the displayed values. To change the values, use the **NewSensor** submenu (Section 4.5.8 on page 4-25).

The values of the H201 sensor's ten parameters are stored in the H201Ti's nonvolatile memory.

4.5.4.2 **ForceSensor Test**

This function is used to test the operation of the Hydran 201 sensor. The Hydran 201Ti verifies the sensor by injecting a small dc current in the sensor for a few seconds and then reading the gas level. This test correlates strongly with the sensor response to dissolved gases and thus allows the H201Ti to reliably assert the actual condition of the sensor. The result is immediately interpreted by the microprocessor as follows:

- If the sensor is operating properly, the message **Good** is displayed, but no message is recorded in the historic data file Events. The H201Ti's display returns to the Main Display mode (see Section 4.2.2 on page 4-4) after the H201 sensor output signal has returned to normal (two minutes).
- If the sensor test fails (in other words, if an alarm condition is detected), the fail alarm is triggered, the test result is recorded in the historic data file Events and a message is displayed on the H201Ti's display.

Note: All alarms are ignored for two minutes following the H201 sensor test.

The messages that can be displayed following a sensor test are shown in Table 4-6 on page 4-20. For the troubleshooting procedure for each of these alarms, see Section 12.1 on page 12-1.

In addition to the manual tests, a semimonthly, automatic test of the H201 sensor is performed the first and fifteenth days of each month at midnight. For each automatic test, certain parameters are recorded in the historic data file Service (see Section 4.5.1.4 on page 4-14) for further analysis by General Electric Canada.

Note: Each H201Ti is configured for a specific H201 sensor. If you receive more than one H201Ti's, take the necessary precautions not to interchange the sensors and H201Ti's.

Table 4-6 - Messages That Can Be Displayed Following a Sensor Test

Message	Signification
Good	Hydran 201 sensor operating properly
Replace SensSoon	Decreased sensor sensibility, replace rapidly
Replace SensNOW	Damaged sensor, replace immediately
CableOpen	Cable disconnected, broken or misconnected
CableShort	Cable misconnected or short-circuited
Sensor Not Inst!	Unable to perform the test

4.5.4.3 **Battery**

This function is used to read the battery voltage and set the battery's alarm parameters:

- **Battery:** Voltage reading at the battery's terminals.
- **Batt.Alr LL:** Set point of battery Low-Low alarm.
- **Batt.Alr L:** Set point of battery Low alarm.
- **BattAlr Delay:** Alarm delay for both set points.

A fail alarm is triggered if the voltage of the battery *gets below* the Low or Low-Low alarm set point for a period of time longer than the delay.

*Note: The **BattAlr Delay** parameter is reset each time the **Setup Lost** alarm condition is detected. This parameter must be set to its former operation value after the alarm condition has disappeared.*

For explanations pertaining to the H201Ti's battery, see Section 2.7 on page 2-15.

4.5.4.4 **ServiceData**

This function is used to read the value of six internal parameters used by the General Electric Canada personnel during Hydran 201Ti maintenance or troubleshooting procedures:

- **ServiceL**
- **ServiceI**

- **ServiceA**
- **ServiceU**
- **ServiceV**
- **ServiceF**

4.5.5 **Date&Time Submenu (Extended Menu Only)**

The **Date&Time** submenu is used to change the date and time of the Hydran 201Ti. The internal clock provides the date and time unless the battery is disconnected.

4.5.6 **Communication Submenu (Extended Menu Only)**

Note: The Hydran 201Ti's communication parameters can only be modified using the H201Ti's keypad and display. They cannot be changed using the Hydran Host software.

This submenu is used to set the communication channel (RS-232 link or supervisory link) and the communication parameters.

4.5.6.1 **CommChannel and DefaultChannel**

The Hydran 201Ti switches automatically from the communication channel indicated with the **CommChannel** parameter to the one indicated with the **DefaultChannel** parameter if the communications cease for five minutes.

- The **CommChannel** parameter is used to select a temporary channel, generally the RS-232 link, for the purpose of connecting a host computer during installation, troubleshooting or maintenance procedures.
- The **DefaultChannel** parameter is used to select the permanent channel, generally the supervisory link.

For each of these two parameters, there are only two available channels:

- **H201Ti-DB9** (RS-232 link): Use this channel if the H201Ti is connected directly to a host computer running the Hydran Host software. For this connection, use the H201Ti's DB-9 male connector located at the back of the CPU module. The RS-232 link is used only occasionally or for brief periods of time during the initial verification or maintenance procedures.
- **SupervisoryLink**: Use this channel if the H201Ti communicates with a H201Ci Controller.

Note: The H201Ti's microprocessor only gives access to one channel at a time.

4.5.6.2 CommMode

This function is used to select the communication mode between the Hydran 201Ti and the Hydran Host software. There are two possibilities:

- **Call OnAlarm:** In this mode, the H201Ti communicates with the Hydran Host through a telephone line when a gas or fail alarm condition is detected. The operation of this mode can be tested using the **Communication;Force HostCall** command (see Section 4.5.6.4 on page 4-22). The frequency and number of call attempts meet the normal regulations of telephone companies.
- **AnswerOnly:** In this mode, the H201Ti remains inactive until being questioned by the host computer running the Hydran Host or any other SCADA system.

4.5.6.3 BaudRate

This function is used to set the serial communication rate of the Hydran 201Ti. The communication can be set at 1,200, 2,400, 4,800 or 9,600 bps (bits per second). All H201Ti's belonging to one network must be set to the same baud rate.

If the **BaudRate** parameter is changed and if the H201Ci Controller is equipped with a modem, always execute the **Communication;Force HostCall** command (see Section 4.5.6.4 on page 4-22) immediately after the modification.

Note: The communication rate of the H201Ti's must be the same as the one set in the Hydran Host software (see the Hydran Host Software Manual).

4.5.6.4 Force HostCall

This function is used to perform two actions:

- To initialize the modem in the H201Ci Controller with the communication rate selected using the **BaudRate** parameter.
- To test the communications between the Hydran 201Ti and the Hydran Host software by forcing the H201Ci Controller's modem to call the modem of the host computer where the Hydran Host is running.

*Note: In the versions 2.1 and prior of the H201Ti embedded software, in the **Call OnAlarm** mode, the telephone number set in the modem's register 0 is dialed automatically at midnight. This function does not exist in version 2.2.*

4.5.6.5 H201Ti ID and PowerStat. ID

The **H201Ti ID** parameter is used to set the Hydran 201Ti's identification number. An exclusive identification number must be assigned to each H201Ti in a local network.

The **PowerStat. ID** parameter is used to set the power station's identification number. The same power station identification number must be assigned to all H201Ti's in a local network, but *each local network must have a different power station identification number.*

The default values of the **H201Ti ID** and **PowerStat. ID** parameters are therefore usually modified. Furthermore, the H201Ti and power station's identification numbers must correspond to those assigned to the same H201Ti's and power station in the Hydran Host software.

WARNING

The identification number of at least one H201Ti in a local network must be set between 1 and 5 (inclusively).

Note: The identification number of each H201Ti must be recorded during the configuration of the local network.

4.5.7 Relays/Analog Submenu (Extended Menu Only)

The **Relays/Analog** submenu is used to:

- Read the state of the alarm relays: **On** or **Off**.
- Set the operation mode of the three alarm relays.
- Select the triggering conditions of the fail alarm (**FaultTrig.**).
- Read the state of the analog output and TDM signal (in %).
- Set the operation mode of the analog output and TDM signal.

4.5.7.1 Gas H Relay

- **RelayH State:** Displays the status of the High alarm relay. The two possible states are explained in Section 10.2.2 on page 10-4.

- **RelayMode:** Is used to set the operation mode of the High alarm relay. The four operation modes are explained in Section 10.2.3 on page 10-5.

4.5.7.2 Gas HH Relay

- **Relay HH State:** Displays the status of the High-High alarm relay. The two possible states are explained in Section 10.2.2 on page 10-4.
- **RelayMode:** Is used to set the operation mode of the High-High alarm relay. The four operation modes are explained in Section 10.2.3 on page 10-5.

4.5.7.3 SysOK Relay

- **SysOK State:** Displays the status of the fail alarm relay. The two possible states are explained in Section 10.2.2 on page 10-4.
- **RelayMode:** Is used to set the operation mode of the fail alarm relay. The four operation modes are explained in Section 10.2.3 on page 10-5.
- **FaultTrig.:** Is used to set to **Off** or **On** each fail alarm condition. For details, see Section 10.5 on page 10-14. Press **CHANGE** to turn on a condition (an asterisk [*] is then displayed at the right of the parameter's name) or turn it off (only the parameter's name is displayed).

4.5.7.4 AnalogOut

- **AnalogState:** Displays the state of the Hydran 201Ti's analog output in percentage of the maximum electric current. The analog output provides the gas level being measured; the displayed percentage is thus directly proportional to the gas level. For details on the analog output, see Section 2.5.2 on page 2-14.
- **AnalogMode:** Is used to set the operation mode of the analog output. The three **Force x %** modes are used only to test the operation of the Hydran 201i System.

Table 4-7 on page 4-25 shows the electrical current generated for each mode.

Table 4-7 - Electrical Current Generated by the Analog Output for Each Operation Mode

Operation Mode	Analog 4–20 mA Output	Hydran 201Ci-1 Display
Force 0 %	4.00 ± 0.10 mA	0 ± 2 ppm
Force 50 %	12.00 ± 0.20 mA	1000 ± 5 ppm
Force 100 %	20.00 ± 0.40 mA	1999 ppm ^a

- a. The maximum value of the Hydran 201Ci-1's display scale is 1999 ppm. If the signal is over scale, the display indicates **1...** when the operation mode is set to **Force 100 %**.

4.5.7.5 TDM Out

- **TDM State:** Displays the state of the Hydran 201Ti's TDM signal, in percentage.
 - Used with the H201Ci-1 Controllers only, the TDM signal is integrated to the supervisory link and is used to transmit the state of the H201Ti's alarm relays and analog output. Only one pair of wires is necessary to transmit this information. For details on the supervisory link, see Section 9.1 on page 9-1.
 - The TDM signal relates to the gas level being measured. The displayed percentage is thus directly proportional to the gas level (% output = ppm/20; 2,000 ppm = 100 %).
- **TDM Mode:** Is used to set the operation mode of the TDM signal. The three **Force x %** modes are used only to test the operation of the Hydran 201i System.

4.5.8 NewSensor Submenu (Extended Menu Only)

The **NewSensor** submenu is used to:

- Set the Hydran 201 sensor parameters.
- Install a new H201 sensor.

This submenu is very similar to the **Service;SensorCal Data** submenu (see Section 4.5.4.1 on page 4-18), except that in the latter submenu the parameter values cannot be changed.

The **NewSensor** command requires password No. 2. The H201 sensor is then immediately tested and the result (**Good** or else) is displayed after three seconds. For details, see Section 4.5.4.2 on page 4-19.

WARNING

Use this submenu only to install a new H201 sensor, because it changes the Service;ServiceData parameters. These parameters are used to evaluate the state of the H201 sensor.

4.5.9 Calibration Submenu (Extended Menu Only)

The **Calibration** submenu is used to calibrate:

- The three analog inputs:
 - The Hydran 201 sensor signal
 - The H201 sensor temperature
 - The heating plate temperature
- The analog output

This command requires password No. 2.

WARNING

If you go further than the *CalibrateNow?* message in this submenu, the calibration is *destroyed*.

There are five branches in this submenu:

- **LowRange**: Calibration of the H201 sensor signal's low range.
- **HighRange**: Calibration of the H201 sensor signal's high range.
- **SensorTemp**: Calibration of the H201 sensor temperature.
- **HeaterTemp**: Calibration of the heating plate temperature.
- **SignAnalog**: Calibration of the analog output.

5.1 GENERAL WARNINGS

1. *Do not separate the Hydran 201Ti Intelligent Transmitters from their respective Hydran 201 sensor.* The H201Ti is set at the factory for a specific H201 sensor. To verify whether the two components are paired correctly, consult the serial numbers indicated on the shipping box and/or the Test Certificate and Data Sheet. The sensor's serial number is located below the connector (see Figure 2-3 on page 2-6), while the H201Ti's serial number is located at the back of the heating plate (see Figure 5-1 on page 5-1).

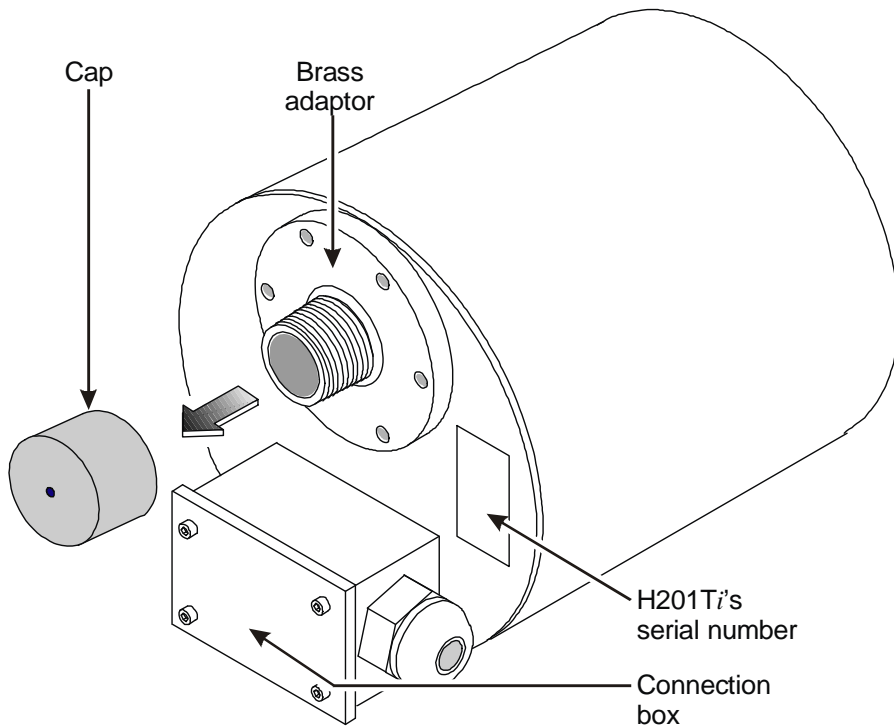

Figure 5-1 - H201Ti's Serial Number and Protective Cap

2. *Do not remove the protective plastic caps* from the sensor and/or the brass adaptor's threaded extremity until ready to install on the transformer valve. These caps protect the adaptor threads (see Figure 5-1 on page 5-1) and the sensor membrane from debris and sharp objects. If the sensor is unmounted, place immediately the supplied cap onto the sensor's threads.

WARNING Mishandling of the Hydran 201 sensor (such as a perforation or scratch on the membrane or subjecting the sensor to paint or solvent) voids the warranty.

3. *Do not touch the H201 sensor's membrane* (located inside the threaded extremity) with a finger or an object (see Figure 5-2 on page 5-2). The membrane is easily impaired; this would damage the sensor permanently, thus voiding the warranty.

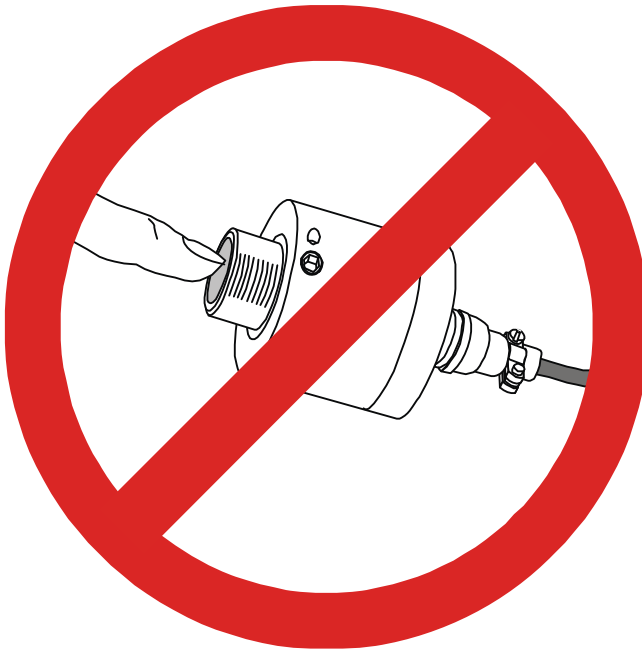

Figure 5-2 - Do Not Touch the Membrane

4. *Do not block or puncture the sensor's breathing membrane.* Located above the sensor's connector (see Figure 2-1 on page 2-3), this opening provides oxygen to the gas detector inside the sensor. Blocking or puncturing this membrane damages the sensor permanently, thus voiding the warranty.

5. *Do not paint the sensor* (see Figure 5-3 on page 5-3). Paint fumes block the sensor's breathing membrane and damage the sensor permanently, thus voiding the warranty.

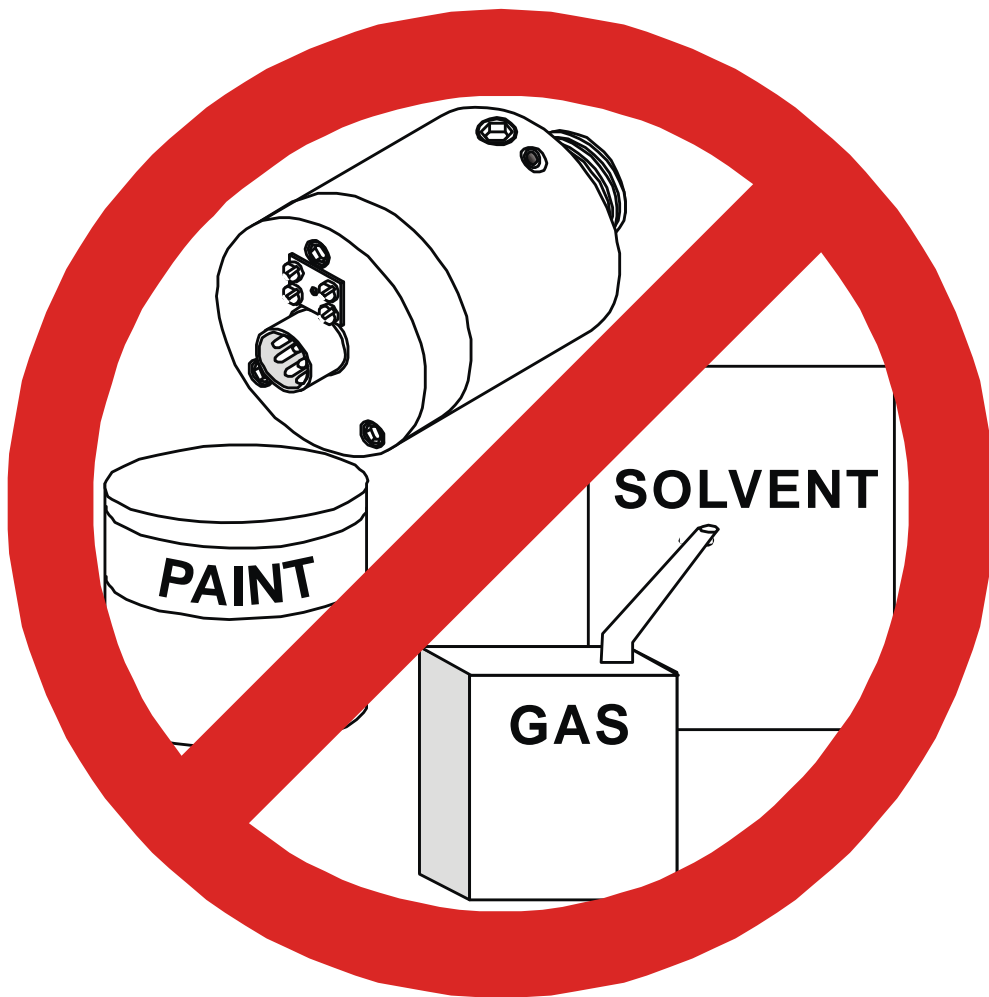

Figure 5-3 - Do Not Paint the Sensor or Clean It With Any Solvent

6. *Do not use hydrocarbon-based compounds near the sensor. Do not clean the sensor with any solvent or other products* (see Figure 5-3 on page 5-3). The volatile fumes of these compounds can deteriorate sensor performances. Products to avoid include: Paint, liquid Teflon, vehicle exhaust, spray can, black pitch, thinner, RTV (Room Temperature Vulcanization; silicon-based mastic) and solvent.

7. *Do not use a pipe wrench or chain wrench to install the sensor. Doing so may cause serious damage to the sensor, thus voiding the warranty. It is recommended to use General Electric Canada's Hydran 201TW tube wrench (see Figure 5-4 on page 5-4) to correctly install the Hydran 201 sensor. One Hydran 201TW tube wrench per site is recommended.*

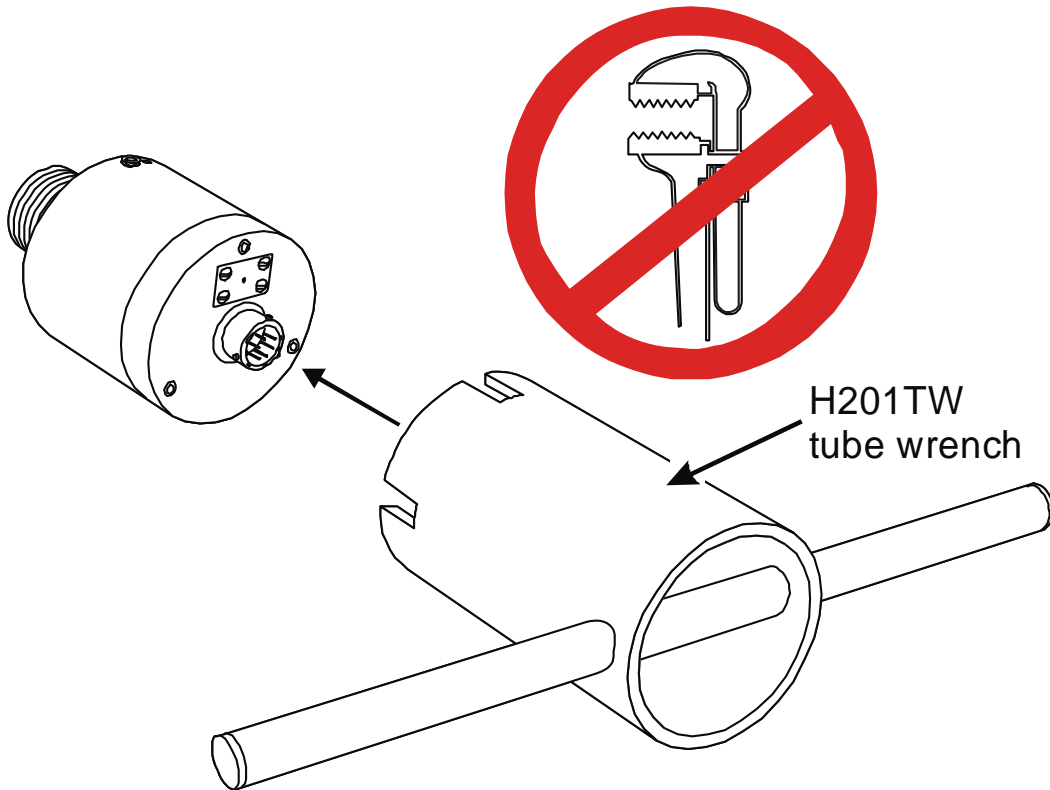

Figure 5-4 - Use the Hydran 201TW Instead of a Pipe Wrench

8. Do not install the H201Ti on the inlet side of the radiator pump (see Figure 5-5 on page 5-5).

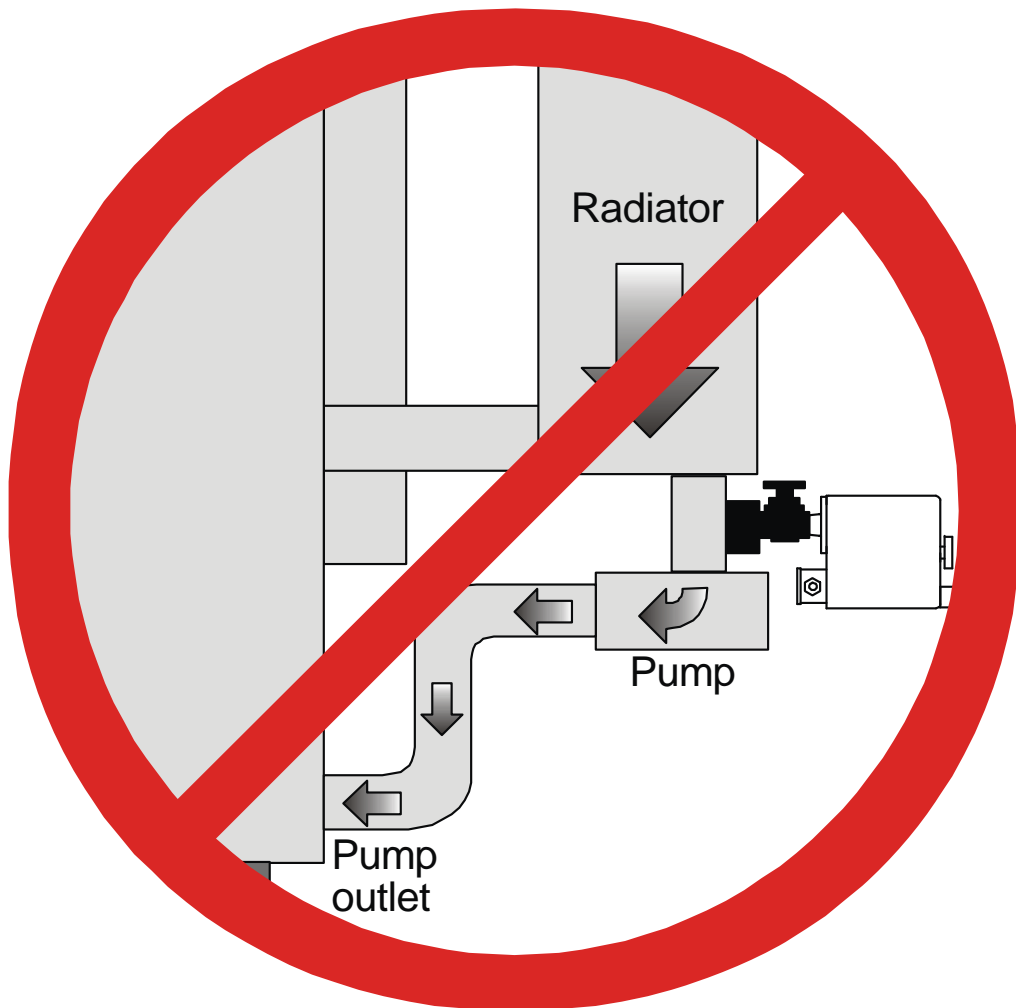

Figure 5-5 - Do Not Install the H201Ti on the Inlet Side of the Radiator Pump

9. Do not use galvanized fittings to install the brass adaptor and the sensor. Galvanized fittings (pipes, reducing bushings, rings, etc.) may react with the oil and produce elevated gas level readings. Similarly, do not use galvanized fittings on transformer valves used for oil sampling.

10. *Install the H201Ti horizontally; not at an angle, vertically or horizontally using an elbow (see Figure 5-6 on page 5-6). Elbows may cause turbulence that can reduce the accuracy of gas level readings. For details pertaining to the positioning of H201Ti's, see Section 5.2.2.2 on page 5-10.*

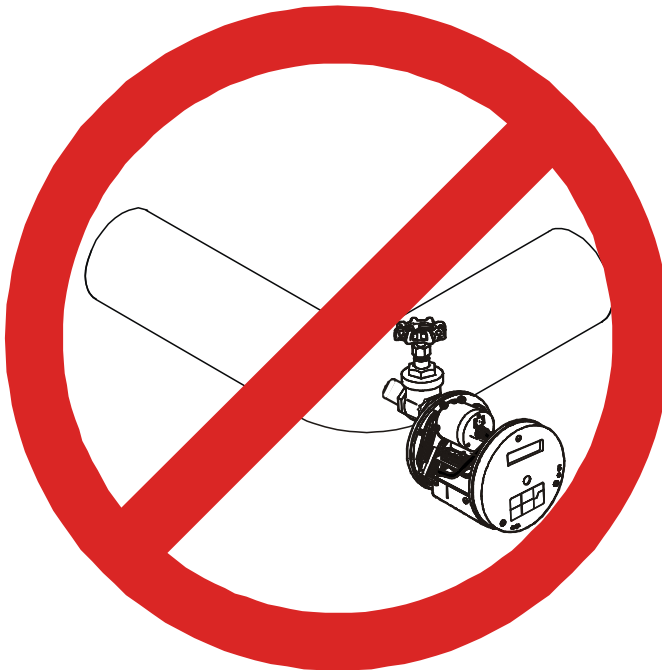

Figure 5-6 - Do Not Install the H201Ti on an Elbow

11. *Do not subject the H201Ti or its sensor to high-pressure water streams (see Figure 5-7 on page 5-6). Used during the cleaning of transformers, they may cause serious damage.*

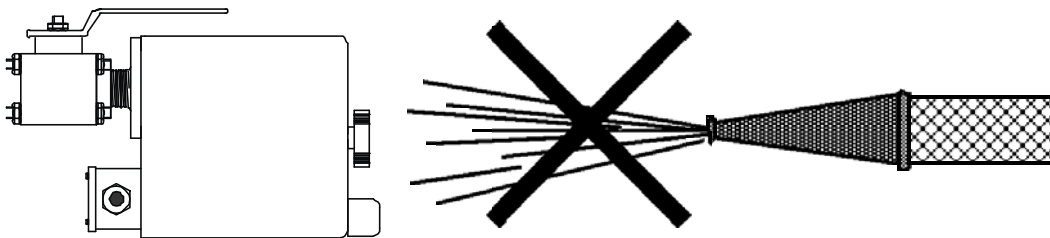

Figure 5-7 - Avoid High-Pressure Water Streams

12. *Do not punch additional openings in the H201Ci Controller's enclosure. This enclosure already has openings for the various cables used with the Hydran 201i System. If additional openings must be made, apply a protective coating to the bare metal around the hole to prevent rust.*
13. *Do not remove the watertight cap from unused openings of the H201Ci's enclosure.*

5.2 INSTALLATION OVERVIEW

A typical installation of the Hydran 201i System is shown in Figure 5-8 on page 5-8. Here is a description of each component:

1. Hydran 201Ci Controller (Hydran 201Ci-C Communications Controller or Hydran 201Ci-1 One-Channel Controller) installed on vibration-absorbing rubber pads (Figure 1-5 on page 1-9)
2. Full-bore gate or ball valve
3. Hydran 201Ti Intelligent Transmitter
4. H201Ti's supervisory link cable in a rigid or flexible steel conduit
5. H201Ti's power supply cable in a rigid or flexible steel conduit
6. Cable for communications and analog outputs in a rigid or flexible steel conduit (distinct from alarm cable conduit), toward a supervisory control and data acquisition (SCADA) system
7. Cable for alarms in a rigid or flexible steel conduit, toward a SCADA system
8. H201Ci Controller's power supply cable in a rigid or flexible steel conduit

WARNING

All procedures in this manual must be strictly adhered to. Any deviation from these could cause irreversible damages to the transformer being monitored and/or the Hydran 201i System, and could lead to property damage, personal injury and/or death. Installation and maintenance of the Hydran 201i System must be carried out by qualified personnel only.

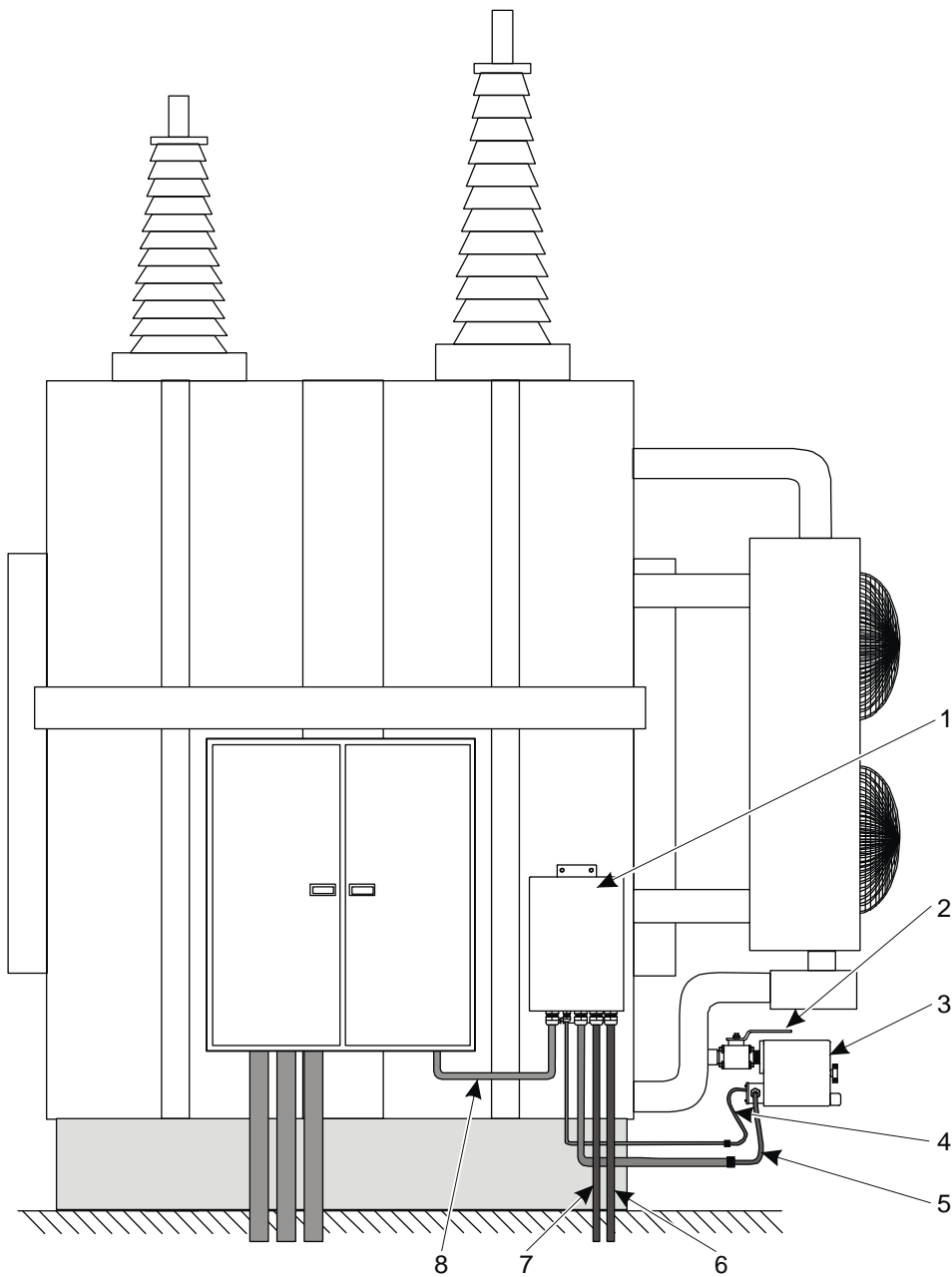

Figure 5-8 - Typical Installation of the Hydran 201i System

5.2.1 Tools and Material Required

- Flat-blade screwdriver
- General Electric Canada's Hydran 201TW tube wrench to tighten the Hydran 201 sensor
- Pipe wrench to tighten the brass adaptor onto the valve
- Allen keys supplied with the Hydran 201Ti (see Section 6.1.2 on page 6-2)
- Bucket and oil-absorbing rags
- Teflon tape and vinyl tape
- Drill, bits and fasteners for mounting the Hydran 201Ci Controller
- If required, vibration-absorbing rubber pads, which can be purchased from General Electric Canada
- Conduits, fittings and cables for power supply, alarms, analog outputs and communications
- Digital voltmeter/ammeter

5.2.2 Mounting Location of the Hydran 201Ti

5.2.2.1 Warnings

For meaningful readings and good response time, the most important factors are proper location and installation of the H201Ti. This Section details the most important considerations for the installation of the H201Ti.

1. Always mount the H201 sensor on a full-bore gate or ball valve where there is sufficient convective oil flow.
2. The H201Ti is installed on a valve with a 1.5-in nominal diameter (NPT female threads). If necessary, use a reducing bushing.

Note: To ensure sufficient oil flow past the sensor's membrane, the nominal diameter of the valve should never be less than 25 mm (1 in). Furthermore, to ensure optimum performance of the H201Ti, the diameter should not exceed 76 mm (3 in).

3. The total distance between the H201Ti and the mounting point of the valve *must not exceed six times the nominal diameter of the valve* (230 mm [9 in] for a 38-mm [1.5-in] valve). See Figure B-1 on page B-1.
4. The body of the valve must be grounded.

- 5. The H201Ti weighs 5.6 kg (12 lb). If the selected valve is subject to strong vibrations, install a supporting bracket to reduce the load on the valve. *In case of doubt, consult your engineering personnel.*

5.2.2.2 Typical Locations

For a typical transformer, the four most common locations to install the Hydran 201Ti are shown in Figure 5-9 on page 5-10.

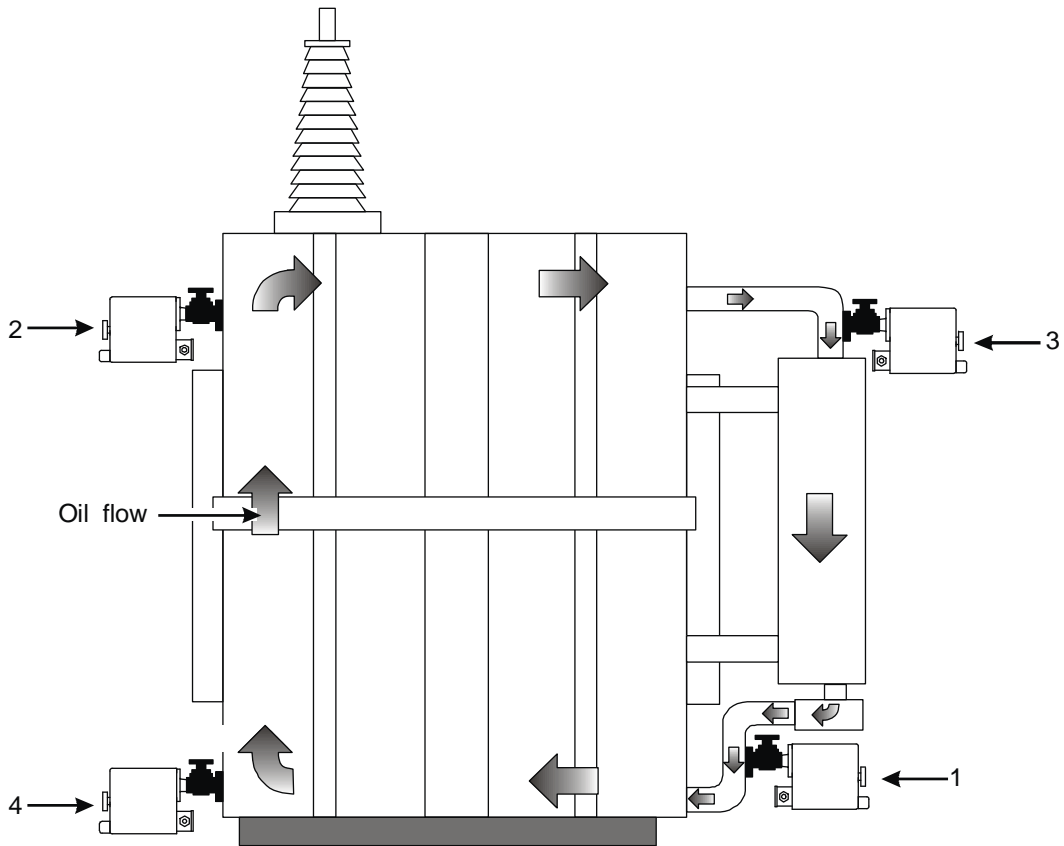

Figure 5-9 - Mounting Locations of the H201Ti on a Transformer

- 1. *Radiator's return pipe:* The recommended location to mount the H201Ti is on the straight section of the radiator's return pipe, which is joining the bottom of the radiator to the transformer's main tank (on the discharge side of the pump to avoid

negative pressure). This location presents the H201Ti with the best combination of oil flow, temperature and ease of access.

2. *Filling valve* (top of tank): In terms of performance (excellent convective oil flow), this location is a very good alternative location to install the H201Ti. However, the higher operating temperatures somewhat reduce the Hydran 201 sensor lifetime. Access to the H201Ti is also more difficult.
3. *Inlet of radiator*: See the comments on location 2.
4. *Drain valve* (bottom of tank): At this location, the H201Ti performances are good, rather than excellent. The low oil flow may affect the gas level readings; however, the lower operating temperatures and ease of access make this location a valid alternative choice.

Also, note the following points:

- The H201Ti must always be easily accessible. The distance between the valve and the ground must exceed 30 cm (12 in) to install and wire the H201Ti.
- Do not install the H201Ti on an elbow (Figure 5-6 on page 5-6) or a fitting box. The turbulent oil flow at these locations may result in inaccurate gas level readings.
- If the H201Ti is mounted directly on the wall of the transformer tank, ensure it is installed below the oil level.
- No obstructions (baffle, pipe, etc.) must exist behind the valve (inside the tank).
- Regardless of the selected location, it is recommended to mount the H201Ti horizontally. If no horizontal valve is available, a vertical installation may be acceptable; contact the General Electric Canada Customer Service (the coordinates can be found at the bottom of page ii). If the H201Ti is installed vertically, note the following points:
 - The sensor's threaded extremity must be oriented upward.
 - The oil temperature at this location must always be below 30 °C (86 °F).
 - Do not use a 90° elbow to convert a vertical installation to a horizontal installation.
 - It is recommended to set the temperature set point (**Temp SetPoint** parameter in the **Temperature** submenu) of the H201 sensor to 45 °C (113 °F).

WARNING

If these four recommended locations cannot be used, contact the General Electric Canada Customer Service (the coordinates can be found at the bottom of page ii) to help you determine an acceptable alternative location.

5.2.3 Mounting Location of Hydran 201Ci Controllers

The following points pertain to all H201Ci Controllers (Hydran 201Ci-C and Hydran 201Ci-1):

1. All H201Ci Controllers are equipped with Type NEMA 4X enclosures and can thus be installed outdoor.
2. The H201Ci Controllers must be mounted on a vibration-free structure. If vibrations are present, use vibration-absorbing rubber pads (Figure 1-5 on page 1-9), which can be purchased from General Electric Canada.
3. The enclosure must be placed at eye level.
4. Allow enough space to open the door completely.
5. Allow enough space to access easily the cable fittings under the enclosure.
6. Good grounding of the enclosure and its supporting structure is essential to protect the equipment against electromagnetic and radiofrequency interference.
7. Install the enclosure as far as possible from circuit breakers or any other strong source of radiofrequency noises. The enclosure can be installed up to 1,200 m (4,000 ft) from the Hydran 201Ti. The *total* length of supervisory links (communication cable between the H201Ci Controller and its H201Ti's) must not exceed 1,200 m (4,000 ft) per H201Ci Controller.
8. Dimensions for the H201Ci-C and H201Ci-1 enclosures are shown in Figure B-7 on page B-5 and Figure B-8 on page B-6.
9. The power supply source of the H201Ci Controller must be protected by an adequate switch or circuit-breaking system as the means for disconnection:
 - The switch or circuit-breaking system must be included in the building installation.
 - It must be in close proximity to the equipment and within easy reach of the operator.
 - It must be marked as the disconnecting device for the equipment.

5.2.4 Cabling and Network Configuration

Several Hydran 201*Ci* Controllers installed in a station can be linked together using an RS-485 link to form a local network. A local network of Hydran 201*i* Systems can include up to 32 H201*Ci* Controllers and 128 Hydran 201*Ti*'s. The H201*Ci* Controllers (Hydran 201*Ci*-C's and/or Hydran 201*Ci*-1's) can all be connected together. The network configuration is explained in Chapter 9.

Any H201*Ci* Controller in a local network can be connected to a host computer (running the General Electric Canada's Hydran Host software) through an RS-232 or USB link to monitor all the H201*Ti*'s in the network. The host computer and the network can also communicate through a modem, thus allowing remote monitoring.

To maximize the benefits of a network, simple guidelines should be followed. Use the following rules to install and implement a network of Hydran 201*i* Systems.

5.2.4.1 Parameter Settings

1. The parameters of each H201*Ti* (identification number, power station identification number, communication speed, alarm set points, operation mode of relays, etc.) must be selected before field installation.
2. Each H201*Ti* of a local network must be set to an individual and exclusive identification number (parameter **H201Ti ID** in the **Communication** submenu) selected between 1 and 254. The numbers can be assigned sequentially or using any other method preferred by the user. *If two H201Ti's share the same number in a local network, they are not able to communicate properly with the host computer.* It can be useful to assign numbers that correspond to the identification numbers of the transformers being monitored; for an example, see Table 5-1 on page 5-14.
3. All H201*Ti*'s belonging to a local network must share a common power station identification number (parameter **PowerStat. ID** in the **Communication** submenu). This number is used when accessing a station remotely, or when analyzing and displaying historic data in the Hydran Host software.
4. All H201*Ti*'s in a local network must be set to the same data communication speed (parameter **BaudRate** in the **Communication** submenu; 1,200, 2,400, 4,800 or 9,600 bps). The recommended speed is 9,600 bps.

Table 5-1 - Example of H201Ti Identification Numbers

Transformer	H201Ti Identification Number
Reserved	1 ^a
T1A	11
T1B	12
T1C	13
T2A	21
T2B	22
T2C	23

a. At least one H201Ti in a local network must be set to an identification number between 1 and 5 (inclusively).

5. The serial number of each component of the Hydran 201i System, the value of the H201Ti's parameters and a general description of the installation (transformer number, power station number, etc.) should be logged and kept in a safe place.
6. The communication parameters must be identical at both ends of the communication channel. In addition the communication speed of both modems must be the same as the H201Ti's and the host computer. Refer to the *Hydran Host Software Manual*.

5.2.4.2 Cabling

1. The maximum length allowed for each cable is as follows:
 - The total maximum length for all supervisory links cables in a single Hydran 201i System (between a H201Ci Controller and its H201Ti's) is 1,200 m (4,000 ft).
 - The total maximum length for all RS-485 link cables between all H201Ci Controllers in a local network is also 1,200 m (4,000 ft).
 - The length of the RS-232 link cable must not exceed 7.7 m (25 ft).
2. All cables that connect the Hydran 201i System's components should be run in steel conduits. The shield of all cables should be grounded at one end only or at the indicated locations. Routing and shielding of the RS-485 link cable are particularly

important because all H201*Ci* Controllers in a local network share a common reference with this link.

WARNING

***ELECTRICAL SHOCK HAZARD.* Turn off the electric power at the fuse box or service panel before making any electrical connections, and ensure a proper ground connection is made before connecting line voltage. Failure to do so can result in property damage, personal injury and/or death.**

3. Because the supervisory link is isolated electrically at both ends, use it rather than the RS-485 link to cover long distances.
4. Electrical noise is one of the most important factors when selecting the location and installing a modem.
5. If the analog outputs and relay contacts must be connected to a SCADA system, it is recommended to install the H201*Ci* Controller near this system and use the supervisory links to cover the distance between the H201*Ti*'s and the H201*Ci* Controller.
 - Transmitting the information using a supervisory link requires only three shielded pairs of wires (two pairs for the H201*Ci*-C).
 - Transmitting the information between the H201*Ci* controller and the SCADA system requires one RS-485 or RS-232 link cable and/or the following pairs for each H201*Ti*:
 - Three pairs for the alarm contacts (High, High-High and system fail alarms)
 - One or two pairs for the analog outputs
 - Because of its digital nature, the supervisory link provides better protection against electrical noise.

5.3 INSTALLATION

To install the components of the Hydran 201*i* System, please consult the following parts of this manual:

- Hydran 201*Ti*: See Chapter 6.
- Hydran 201*Ci*-C: See Chapter 7.
- Hydran 201*Ci*-1: See Chapter 8.
- Local network: See Section 9.5 on page 9-8.
- Optional modem: See Section 9.6 on page 9-11.

PAGE LEFT INTENTIONALLY BLANK

Hydran 201Ti Installation

Please read the following Sections before proceeding with the installation:

- User interface, in Section 4.1 on page 4-1
- General warnings, in Section 5.1 on page 5-1
- Installation overview, in Section 5.2 on page 5-7

Note: It is recommended to use the Hydran Host software rather than the H201Ti's user interface (keypad and display). See the Hydran Host Software Manual.

6.1 INCOMING INSPECTION AND VERIFICATION

It is strongly recommended to verify the operation of the H201Ti's and Hydran 201Ci Controllers before their installation. This verification also confirms that no damage occurred during shipping and allows the user to become familiar with the Hydran 201i System. The H201Ti installation procedure is described in Section 6.3 on page 6-17.

6.1.1 Receiving and Unpacking

Upon receipt, the shipping box contains one preassembled H201Ti, complete with a transmitter enclosure, a Hydran 201 sensor, electronic modules (CPU and I/O), and a flanged brass adaptor. For the shipping list, see Section 6.1.2 on page 6-2; for a detailed view of the component assembly of the H201Ti, see Figure 6-2 on page 6-18.

1. Open the shipping box.
2. Remove the documentation and the small bag containing accessories and tools.
3. Carefully remove the H201Ti from the box.

WARNING

Do not remove the plastic cap from the flanged brass adaptor. This cap protects the adaptor's threads and membrane.

Note: Keep the packing material for storage or further shipment of the H201Ti.

6.1.2 Shipping List

This Section lists all the items included in the shipment of a Hydran 201Ti. If any item is missing, contact the General Electric Canada Customer Service (the coordinates can be found at the bottom of page ii).

1. One pre-assembled H201Ti, including:

- One enclosure, with heating plate, aluminum cover and knob
- One Hydran 201 sensor
- One flanged brass adaptor
- One main (CPU) module, with display and keypad
- One I/O module, with terminal blocks

2. Two cables:

- One RS-232 cable of 1.8 m (6 ft)
- One supervisory link cable (30, 50 or 100 ft [9, 15 or 30 m]), with six wires and an overall shield

Note: This supervisory link cable is supplied only when the H201Ti is part of a Hydran 201R Model i or is ordered with any Hydran 201Ci Controller.

3. Software and manuals:

- One installation CD-ROM that includes the following items:
 - The Hydran Host software
 - Three manuals in PDF format: The *Hydran 201i System Instruction Manual* (the present manual), the *Hydran 201i System Installation Guide* and the *Hydran Host Software Manual*
- One printed *Hydran 201i System Installation Guide*

4. One set of tools and accessories:

- One 3/16-in (4.75 mm) Allen key with a 9-in (229 mm) T-shape handle (part number 11817)
- One 5/32-in (4 mm) Allen key with a short L-shape handle (part number 10013)

- One 7/64-in (2.8 mm) Allen key with a short L-shape handle (part number 10011)
- One blue protective cap for the H201 sensor
- One roll of Teflon tape

6.1.3 Inspecting

Verify the Hydran 201Ti completely as outlined below.

1. Using the shipping list (see Section 6.1.2 on page 6-2), ensure all items are present.
2. Inspect the following components for any visual damage (bump, scratch or others):
 - The enclosure
 - The brass adaptor
 - The Hydran 201 sensor
 - The CPU module
 - The input/output (I/O) module
3. Verify the ac power supply voltage (indicated on the left side of the I/O module) corresponds to the power source voltage and the value on the Test Certificate and Data Sheet (for an example, see Figure 6-1 on page 6-4). The left side is determined by facing the H201Ti's display and keypad. There are two possibilities:
 - 115 V, corresponding to a 90–132 Vac range from 47 to 63 Hz
 - 230 V, corresponding to a 180–264 Vac range from 47 to 63 Hz
4. Verify the type and size of the supplied flanged brass adaptor:
 - 1-in NPT (outside diameter 1.25 in [32 mm]): See Figure B-4 on page B-3.
 - 1.5-in NPT (outside diameter 1.75 in [44 mm]): See Figure B-3 on page B-2.
 - 1.5-in NPT finned for high temperatures: See Figure B-6 on page B-4.
 - 2-in NPT (outside diameter 2.25 in [57 mm]): See Figure B-5 on page B-4.



GE Energy Services
 Network Reliability Products and Services
 General Electric Canada
 179 Brunswick Blvd., Pointe-Claire, Quebec H9R 5N2 CANADA
 Tel: (1) 514 693-1400, Fax: (1) 514 694-9245
 E-mail: transformermonitoring@ps.ge.com
 Web site: www.gepower.com/prod_serv/subst_ntwk.htm

Detection and Monitoring of Failure Conditions
 in Oil-filled Electrical Equipment

Form: S-019E
 Issue date: 1998-01-06
 Revision date: 2006-03-11
 Revision: 6

HYDRAN 201Ti
TEST CERTIFICATE AND DATA SHEET

This data sheet is to be used with the HYDRAN 201Ti
 verification and installation section in the instruction manual

Date: 2006-08-29 **Customer:** OEM Stock, Taiwan

Hydran 201 Ti Data

H201Ti S/N: 0608413334
 CPU Module S/N: 0608413334
 I/O Module S/N: 0608413334
 Micro P Code: 4505
 Flash Code: 406
 Embedded Version: 2.2 L
 Analog Output: 0-1 mA
 Operating Voltage: 230VAC
 Brass Adaptor: 1.5"

Sensor Data 0-2000 PPM

Sensor S/N: 47457
 B: 165
 M: 730
 N: 245
 S: 3833
 A1: 1101
 A2: 1522
 A3: 1712
 A4: 1699
 A5: 0
 A6: 0
 Chksum: 1096
 tp1 Cold: 1.83
 tp1 Hot: 3.54

yyyy - mm - dd

Sensor Calibration:	<u>Narima</u>	2006-06-13
H201Ti Check and Burn-in:	<u>HTRAN</u>	2006-08-08
H201Ti Calibration:	<u>HTRAN</u>	2006-08-03
Verified:	<u>[Signature]</u>	2006-08-29
Approved:	<u>[Signature]</u>	2006-08-29

Figure 6-1 - Example of Test Certificate and Data Sheet for the Hydran 201Ti

5. Ensure the serial numbers of the following H201Ti's components correspond to those indicated on the Test Certificate and Data Sheet (for an example, see Figure 6-1 on page 6-4) and on the shipping box:
 - Serial number of the H201Ti (located on the back of the heating plate; see item 2 in Figure 2-2 on page 2-5)
 - Serial number of the CPU module (located on the back of the module; see item 4 in Figure 2-2 on page 2-5)
 - Serial number of the I/O module (located under the module; see item 6 in Figure 2-2 on page 2-5)
 - Serial number of the sensor (located under the sensor's connector; see item 3 in Figure 2-2 on page 2-5)

Note: Each H201Ti is configured for a specific sensor. If several H201Ti's are received, take the necessary precautions not to swap the sensors and H201Ti's.

6. Report any discrepancies to the company supervisor and the General Electric Canada Customer Service (the coordinates can be found at the bottom of page ii).

Note: Never return equipment without first contacting the General Electric Canada Customer Service.

6.1.4 Storage and Battery Care

If the Hydran 201Ti is not installed immediately, it is strongly recommended to store it in its original shipping box in a safe place. The plastic cap must be left on the adaptor to protect its threads and the membrane.

Storage should be at a temperature between 5 and 45 °C (41 and 113 °F) and a non-condensing, relative humidity between 5 and 95 %; if these limits are to be exceeded, please contact the General Electric Canada Customer Service (the coordinates can be found at the bottom of page ii). These restrictions do not apply to transportation.

When storing the H201Ti for more than six months, it is recommended to disconnect the lithium battery located inside the CPU module (see item 4 in Figure 2-2 on page 2-5); to disconnect and reconnect the battery, see Section 2.7.2 on page 2-15. The battery has a shelf life (when unused) exceeding ten years; if the battery remains connected when the H201Ti is not powered, operation of the real-time clock and data memory reduces its life to approximately three years.

6.2 VERIFICATION OF OPERATION PRIOR TO INSTALLATION

It is strongly recommended to verify the operation of the Hydran 201Ti's before installation in the field (for the installation procedure, see Section 6.3 on page 6-17). The verification confirms that no damage occurred during shipping and allows the user to become familiar with the H201Ti.

6.2.1 Preparation

1. Place the Hydran 201Ti upward on its brass adaptor end.
2. Unscrew the knob on the front of the aluminum cover.
3. Remove the cover and place it aside.
4. Connect a three-wire power cord to the ac Power 3-Terminal Block on top of the I/O module (item 8 in Figure 2-4 on page 2-8): The live side to **L1/L**, the other side to **L2/N**, and the ground to **E/G**. For additional wiring details, see Table D-1 on page D-1.

Note: If a supervisory link cable is attached to the H201Ti, do not connect it to the Hydran 201Ci Controller now. It will be connected later when testing the H201Ci (if supplied).

WARNING

Strip each wire to a maximum of 8 mm before installing it. Be sure to insert all strands in the terminal.

5. Ensure the ac power supply voltage indicated on the label near the terminal block corresponds to the power source voltage.
6. Power On the H201Ti.

WARNING

***ELECTRICAL SHOCK HAZARD.* Turn off the electric power at the fuse box or service panel before making any electrical connections, and ensure a proper ground connection is made before connecting line voltage. Failure to do so can result in property damage, personal injury and/or death.**

6.2.2 Initial Observations

1. If the battery was just reconnected, the H201Ti performs the first power-up sequence (see Section 4.2.5.3 on page 4-7). Enter the requested parameters (date, time, etc.) using the H201Ti's keypad.
2. Observe the display and ensure the H201Ti goes through the self-test sequence shown in Table 4-2 on page 4-6.

*Note: The self-test sequence is executed only if the power was down for more than five minutes. Otherwise, only the message **System;Initialization** appears.*

*Note: A sensor test is executed at the end of the self-test sequence only if the scheduled last sensor test was not performed. In this case, the H201Ti displays the message **Sensor Good** and waits 120 seconds before resuming normal display.*

3. Verify that the H201Ti displays the Main Display mode (the parameters shown in Table 4-1 on page 4-5, at the rate of one every five seconds).
4. Verify the operation of the H201Ti by observing the six small LED diagnostic indicators on the right side of the I/O module (from left to right in Figure 2-7 on page 2-12):
 -  - **Heating state LED**: This yellow LED flashes once every five seconds in proportion to the amount of power supplied to the heating plate.
 - The LED must remain lit if the internal temperature is below the set point (adjustable **Temp SetPoint** parameter in the **Temperature;DynOil Sampl** submenu).
 - The LED must flash if the internal temperature is close to the set point.
 - The LED must remain off if the internal temperature exceeds the set point.
 - **-5 - Regulated -5 Vdc supply LED**: This dim, green LED must be lit to confirm the presence of the -5 Vdc power supply.
 - **+5 - Regulated +5 Vdc supply LED**: This dim, green LED must be lit to confirm the presence of the +5 Vdc power supply.
 - **OK - System state indicator LED**: This green LED must be lit to confirm that the H201Ti is operating properly and that the fail alarm relay is energized. It turns off if a fail alarm condition is detected and if the fail alarm relay is de-energized.
 - **HH - High-High alarm state LED**: This red LED is lit when a High-High alarm condition is detected and the High-High alarm relay is energized. This LED must therefore be off.

- **H - High alarm state LED:** This red LED is lit when a High alarm condition is detected and the High alarm relay is energized. This LED must therefore be off.
5. Wait a few minutes and touch the back of the heating plate (item 2 in Figure 2-2 on page 2-5). It should be warm if the LED  (item 21 in Figure 2-7 on page 2-12) is blinking. This indicates the sensor is being heated to the default temperature setting of the H201Ti (35 °C or 95 °F).
 6. Press **ENTER** once on the membrane keypad. The following screen should be displayed:

H201Ti V2.2x
MainMenu

7. Press **END** or **ESC** to return to the Main Display mode. This confirms keypad operation.

Note: The membrane keys have no “feel,” due to the extremely wide temperature range of this membrane keypad that prevents the use of clicking domes under the keys.

8. Make a shadow over the display and verify that the backlighting is functioning. Although it appears dim in daylight, the backlight allows easy reading of the display at night. This backlit LCD display, with automatic temperature-compensation of contrast, is perfectly readable under all ambient lighting conditions and over the full operating temperature range of the H201Ti.

6.2.3 Adjusting the Date and Time

1. Access the main menu by pushing **ENTER**.
2. Access the extended menu by pushing **CHANGE**.
3. Enter the password #1 (**1253**) using the **UP** and **ENTER** keys.
4. Access the top of the extended menu by pushing **ENTER** twice (**History** appears).

Note: Once accessed, the extended menu times out after 30 minutes of keypad inactivity. Repeat the steps 1 to 4 above if necessary.

5. Push **DOWN** four times until **Date&Time** appears.
6. Access this menu by pushing **ENTER**.
7. Select **Year** using the **DOWN** or **UP** key.
8. To be able to adjust this value, push **CHANGE**.
9. When asked to enter the password #1 (**1253**), use the **UP** and **ENTER** keys.
10. Modify the value using the **UP**, **DOWN** and **ENTER** keys.
11. Adjust the **Month**, **Day**, **Hour** and **Min** by repeating the steps 7 to 10 above.
12. When the **Date & Time** is adjusted, push **END**.
13. To abort an operation if needed, push **ESC**.

6.2.4 Verifying the Alarm Relays

The steps described in this Section may be used during the Hydran 201Ti verification, maintenance and troubleshooting procedures; certain steps may therefore not apply to your particular situation. Perform all the procedures (from Section 6.2.4.1 on page 6-9 to Section 6.2.4.6 on page 6-12).

To verify the relays using the alarm contacts, connect an ohmmeter to the Alarm Contacts 9-Terminal Block (item 12 in Figure 2-5 on page 2-9). To identify each terminal, see Table D-2 on page D-1.

6.2.4.1 Gas High Alarm

1. Access the top of the extended menu by pushing **ENTER** twice (**History** appears).

Note: Once accessed, the extended menu times out after 30 minutes of keypad inactivity.

2. Access the submenu **H201Ti V2.2x;Relays/Analog**.
3. Access the submenu **Relays/Analog;GasH Relay**.
4. Access this relay by pushing **ENTER** (the state of the relay is now displayed).

5. Set this relay's parameter **RelayMode** to **Force ON**.
6. When asked to enter the password #1 (**1253**), use the **UP** and **ENTER** keys.
7. Ensure:
 - The High alarm state LED **H** (item 27 in Figure 2-7 on page 2-12) is lit.
 - The NO contact of the High alarm is closed.
 - The NC contact of the High alarm is open.
 - The state of the other contacts and state LED's has not changed.
 - If connected, the supervisory control and data acquisition (SCADA) system has detected the alarm.

Note: The relay contacts can also be verified using an ohmmeter. Refer to Table D-2 on page D-1 for the terminal block wiring.

6.2.4.2 Gas High-High Alarm

1. Access the submenu **Relays/Analog;GasHH Relay**.
2. Access this relay by pushing **ENTER** (the state of the relay is now displayed).
3. Set this relay's parameter **RelayMode** to **Force ON**.
4. Ensure:
 - The High-High alarm state LED **HH** (item 26 in Figure 2-7 on page 2-12) is lit.
 - The NO contact of the High-High alarm is closed.
 - The NC contact of the High-High alarm is open.
 - The state of the other contacts and state LED's has not changed.
 - If connected, the SCADA system has detected the alarm.

6.2.4.3 Fail Alarm

1. Access the submenu **Relays/Analog;SysOK Relay**.
2. Access this relay by pushing **ENTER** (the state of the relay is now displayed).
3. Set this relay's parameter **RelayMode** to **Force OFF**.

4. Ensure:

- The System state indicator LED **OK** (item 25 in Figure 2-7 on page 2-12) is off.
- The NO contact of the fail alarm is open.
- The NC contact of the fail alarm is closed.
- If connected, the SCADA system has detected the alarm.

6.2.4.4 Cancelling the Fail Alarm

1. Set the same parameter **RelayMode** to **Normal**.

2. Ensure:

- The System state indicator LED **OK** (item 25 in Figure 2-7 on page 2-12) is lit.
- The NO contact of the fail alarm is closed.
- The NC contact of the fail alarm is open.
- If connected, the SCADA system has detected the state change of the fail alarm relay.

6.2.4.5 Cancelling the Gas Alarms

1. Access the submenu **Relays/Analog;GasH Relay**.

2. Set this relay's parameter **RelayMode** to **Normal**.

3. Access the submenu **Relays/Analog;GasHH Relay**.

4. Set this relay's parameter **RelayMode** to **Normal**.

5. Ensure:

- The High alarm state LED **H** (item 27 in Figure 2-7 on page 2-12) is off.
- The High-High alarm state LED **HH** (item 26 in Figure 2-7 on page 2-12) is off.
- The System state indicator LED **OK** (item 25 in Figure 2-7 on page 2-12) is lit.
- The NO contact of the High alarm is open.
- The NC contact of the High alarm is closed.
- The NO contact of the High-High alarm is open.
- The NC contact of the High-High alarm is closed.
- The NO contact of the fail alarm is closed.
- The NC contact of the fail alarm is open.

- If connected, the SCADA system has detected the state change of both gas alarm relays.

6.2.4.6 Conclusion

1. If necessary, set the parameter **RelayMode** of each alarm relay to their initial mode.
2. When all three relays have been tested, push **END**.
3. To abort an operation if needed, push **ESC**.

6.2.5 Verifying the Backup Battery

1. Access the top of the extended menu by pushing **ENTER** twice (**History** appears).

Note: Once accessed, the extended menu times out after 30 minutes of keypad inactivity.

2. Push **DOWN** three times until **Service** appears.
3. Access this menu by pushing **ENTER**.
4. Push **DOWN** twice until **Backup Battery** appears.
5. Read the battery voltage by pushing **ENTER**. The value must exceed 2.9 V.

Note: The Hydran 201Ti requires a minimum of 2.2 V to operate correctly.

6. When all is done, push **END**.

6.2.6 Sensor Serial Number Verification and Sensor Test

1. Access the top of the extended menu by pushing **ENTER** twice (**History** appears).

Note: Once accessed, the extended menu times out after 30 minutes of keypad inactivity.

2. Push **DOWN** three times until **Service** appears.
3. Access this menu by pushing **ENTER**.
4. Read the serial number by pushing **ENTER**.

5. Compare the serial number displayed with the one located under the sensor's connector (see item 3 in Figure 2-2 on page 2-5).
6. Push **ESC** and **DOWN** to access **Force Sensor Test**.
7. Push **ENTER**. The message **AreYou Sure?;PressEnter..** is now displayed.
8. Push **ENTER** again to confirm.
9. When asked to enter the password #1 (**1253**), use the **UP** and **ENTER** keys.
10. The message **Please wait...** appears, the test is executed (during a four-second countdown), and the H201Ti's display should indicate the message **Good**. If another message is displayed, see Section 12.1.3 on page 12-2.
11. When all is done, push **END**. The Hydran 201Ti returns to the Main Display mode.

6.2.7 Adjusting the Temperature Set Point

1. Allow 30 minutes after power-up for the temperatures to stabilize.
2. Access the top of the extended menu by pushing **ENTER** twice (**History** appears).

Note: Once accessed, the extended menu times out after 30 minutes of keypad inactivity.

3. Push **DOWN** twice until **Temperatures** appears.
4. Access this menu by pushing **ENTER**.
5. Push **UP** until **Dyn Oil Sampl** appears.
6. Access this menu by pushing **ENTER**.
7. Select **Heater Power** using the **DOWN** or **UP** key.
8. Check the **Heater Power** is in the low percent range.
9. Select **Temp Setpoint** using the **DOWN** or **UP** key.
10. Check the **Temp Setpoint** is 35 °C (95 °F), the default value.

11. Modify the **Temp Setpoint** by pushing **CHANGE**.
12. When asked to enter the password #1 (**1253**), use the **UP** and **ENTER** keys.
13. Decrease the **Temp Setpoint** to 30 °C (86 °F) using the **UP** and **ENTER** keys.
14. Return to a previous level of the menu by pushing **ESC**.
15. Re-enter the menu using the **DOWN** or **UP** key.
16. Check the **Temp Setpoint** has changed to 30 °C (86 °F).
17. When all is done, push **END**.

*Note: Reset the **Temp Setpoint** to 35 °C (95 °F), the default value.*

6.2.8 Verifying the Analog Output (Facultative)

Table 4-7 on page 4-25 lists the values of the electrical current that should be generated for each operation mode.

1. Connect a suitable dc digital ammeter with a 1 % accuracy and a 0.01 mA resolution to the terminal screws 7 (+) and 8 (-) of the Supervisory Link and Analog Output Termination Board (see item 9 in Figure 2-4 on page 2-8). Refer to Table D-6 on page D-3 for connection details.
2. Access the top of the extended menu by pushing **ENTER** twice (**History** appears).

Note: Once accessed, the extended menu times out after 30 minutes of keypad inactivity.

3. Push **DOWN** six times until **Relays/Analog** appears.
4. Access this menu by pushing **ENTER**.
5. Push **DOWN** three times until **Analog out** appears.
6. Read the analog output state by pushing **ENTER**. The value should be close to 0 %.
7. Push **DOWN** to access **Analog Out Mode**. The value should be **Normal**.

8. Modify the **Analog Out Mode** by pushing **CHANGE**.
9. When asked to enter the password #1 (**1253**), use the **UP** and **ENTER** keys.
10. Push **DOWN** three times and **ENTER** to force the output to **0 %**.
11. Allow about one minute for the output to stabilize.
12. Verify the ammeter reads 4.00 ± 0.10 mA.
13. Push **CHANGE**, **UP** and **ENTER** to force the output to **50 %**.
14. Allow about one minute for the output to stabilize.
15. Verify the ammeter reads 12.00 ± 0.20 mA.
16. Push **CHANGE**, **UP** and **ENTER** to force the output to **100 %**.
17. Allow about one minute for the output to stabilize.
18. Verify the ammeter reads 20.00 ± 0.40 mA.
19. Push **CHANGE**, **UP** and **ENTER** to return the output to **Normal**.
20. When all is done, push **END**.
21. Disconnect the ammeter.

6.2.9 Verifying the RS-232 Communication (Facultative)

This procedure requires the use of the Hydran Host software. Please refer to the *Hydran Host Software Manual*.

1. Using the supplied RS-232 cable, connect the Hydran 201Ti to a host computer through their DB-9 connector. Refer to Table D-7 on page D-4 for connection details.
2. Access the top of the extended menu by pushing **ENTER** twice (**History** appears).

Note: Once accessed, the extended menu times out after 30 minutes of keypad inactivity.

3. Push **DOWN** five times until **Communication** appears.
4. Access this menu by pushing **ENTER**.
5. Modify the **Comm Channel** by pushing **CHANGE**.
6. When asked to enter the password #1 (**1253**), use the **UP** and **ENTER** keys.
7. Change the **Comm Channel** to **H201Ti-DB9** using the **UP** and **ENTER** keys.
8. Modify the **Default Channel** by pushing **DOWN** and **CHANGE**.
9. Change the **Default Channel** to **H201Ti-DB9** using the **UP** and **ENTER** keys.
10. Push **DOWN** four times and **ENTER** to modify the **Gas Monitor ID**.
11. Write down the current value of the **Gas Monitor ID**.
12. Change the **Gas Monitor ID** to **1** using the **UP**, **DOWN** and **ENTER** keys.
13. When all is done, push **END**.
14. Start the Hydran Host software. Please refer to the *Hydran Host Software Manual*.
15. In the opening window, go to the **Main Menu** and choose **Network Setting**.
16. Check [] the station No. 1 and uncheck [] all the other stations.
17. Return to the **Main Menu**.
18. Select the **Real-Time Logging** menu.
19. Set **H201Ti List** to **Same as Network** and set **Log Rate** to **5 seconds**.
20. Return to the **Main Menu** and then to the opening window.
21. Verify that a new line of information is logged on the PC screen once every five seconds.

22. When the testing is completed, repeat the steps 2 to 13 above but restore the original communication settings to the following:

- **Comm Channel = Supervisory Link**
- **Default Channel = Supervisory Link**
- **Gas Monitor ID** = Initial value noted in the step 11 above

23. Disconnect the RS-232 link cable.

6.2.10 Completing the Verification

This completes the incoming verification of the Hydran 201Ti.

1. Disconnect the H201Ti from the power outlet.
2. If a Hydran 201Ci-C is available, perform the procedure in Section 7.2 on page 7-2.
3. If a Hydran 201Ci-1 is available, perform the procedure in Section 8.2 on page 8-2.
4. If no H201Ci Controller is available, remove the power and computer cables from the H201Ti.
5. Close the H201Ti cover.
6. Store the H201Ti in its box, ready for installation.
7. If the H201Ti is not installed immediately, refer to Section 6.1.4 on page 6-5.

6.3 INSTALLATION

This Section explains how to install the Hydran 201Ti, the brass adaptor and the Hydran 201 sensor; it refers to Figure 6-2 on page 6-18.

WARNING

Read all the warnings and recommendations in Section 5.1 on page 5-1 before proceeding with the installation.

Note: It is strongly recommended that the operation of all H201Ti's and H201Ci Controllers be verified before installation of the equipment in the field. Verification also allows the user to become familiar with the Hydran 201i System.

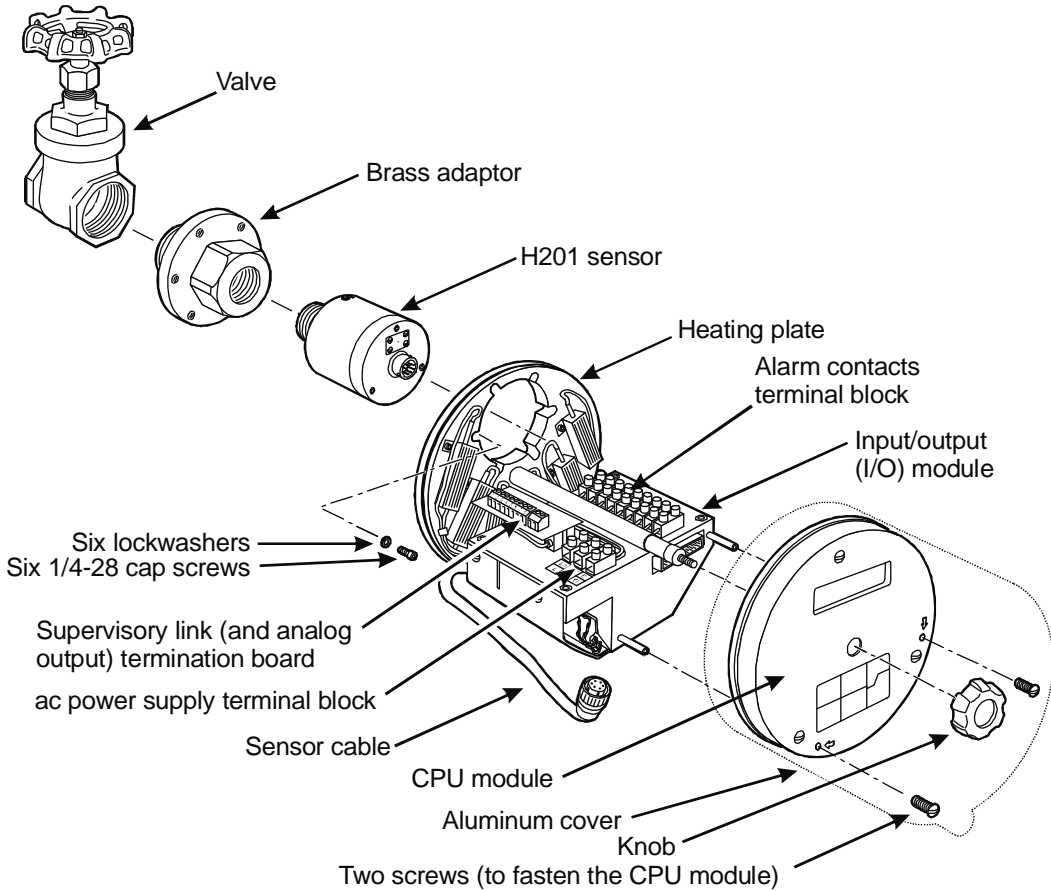

Figure 6-2 - Hydran 201Ti Assembly

WARNING

All procedures in this manual must be strictly adhered to. Any deviation from these could cause irreversible damages to the transformer being monitored and/or the Hydran 201i System, and could lead to property damage, personal injury and/or death. Installation and maintenance of the Hydran 201i System must be carried out by qualified personnel only.

6.3.1 Verifying the ac Power Supply Voltage and the Serial Numbers

Ensure step 3 on page 6-3 and step 5 on page 6-5 have been performed.

6.3.2 Preparing the Hydran 201Ti

6.3.2.1 Removing the CPU Module

1. Unscrew the H201Ti's aluminum cover knob.
2. Remove the cover.
3. Remove *only* the two screws used to fasten the CPU module and identified with arrows (see Figure 6-3 on page 6-19).

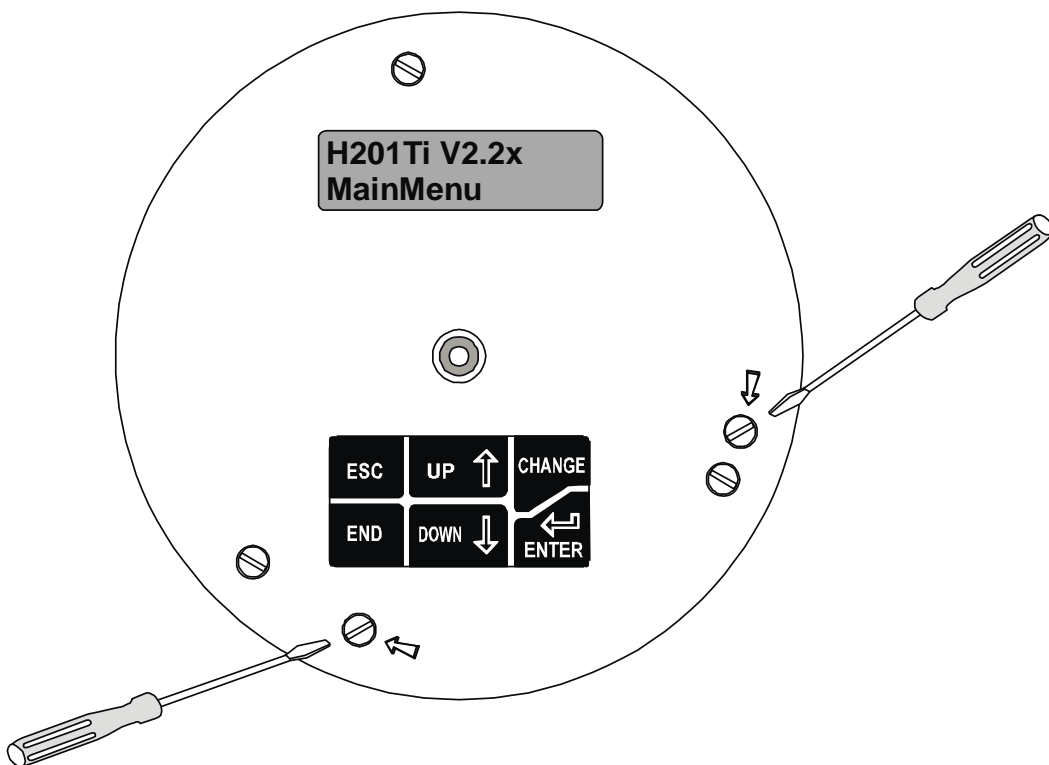

Figure 6-3 - Screws Used to Fasten the CPU Module

- Carefully pull out the CPU module.

WARNING

When removing the CPU module, make sure not to bend the pins of the connector located between the CPU and I/O modules.

6.3.2.2 Separating the Brass Adaptor From the Heating Plate

- Disconnect the Hydran 201 sensor's connector.
- Remove the six 1/4-28 cap screws from the adaptor using the supplied 3/16-in Allen key.
- Separate the adaptor and the heating plate.
- Protect the adaptor's threads with the supplied plastic cap.

6.3.2.3 Removing the Hydran 201 Sensor

- Unscrew the sensor to separate it from the brass adaptor.

WARNING

Do not touch the H201 sensor's membrane for any reason.

- Inspect the sensor's membrane by looking at it. Its surface must be flat, without cuts or tears.
- Protect the sensor's membrane by placing the supplied plastic cap over the sensor's threads.

6.3.2.4 Conclusion

- Store the parts, the brass adaptor and the Hydran 201 sensor in a box and in a safe place until ready for installation.
- Compare the contents to the list in Section 6.1.2 on page 6-2.

Note: If the Hydran 201Ti has been in storage for more than six months, the battery located inside the cover of the CPU module might be disconnected, as recommended by General

Electric Canada. Reconnect the battery before installation; procedures to disconnect and reconnect the battery are both given in Section 2.7.2 on page 2-15

6.3.3 Preparing the Valve

1. Wipe the inside of the valve.
2. Clean the valve's threads.
3. Wipe up any trace of oil and dispose of the collected oil according to company standards.

6.3.4 Installing the Brass Adaptor Onto the Valve

1. Cover the adaptor's threads with Teflon tape (see Figure 6-4 on page 6-21).

WARNING

Use only Teflon tape to seal the threads of both the adaptor and Hydran 201 sensor. Wrap at least 4 to 5 layers of tape around the threads.

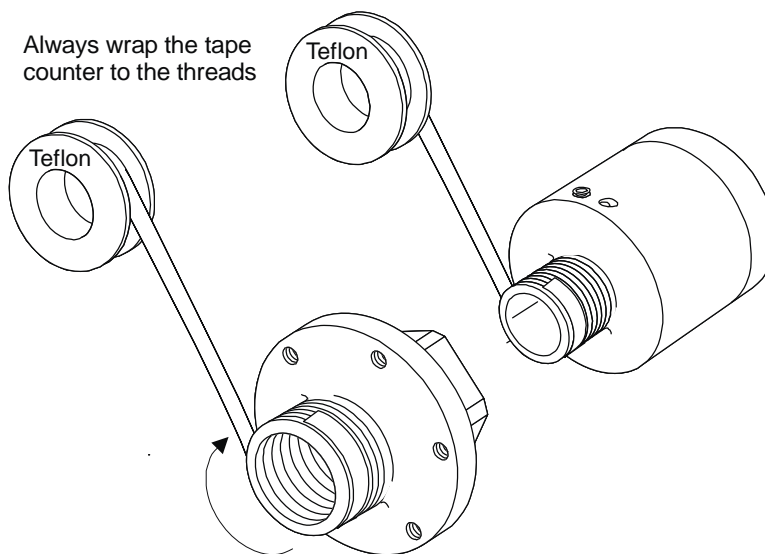

Figure 6-4 - Always Cover the Threads of the Adaptor and Sensor With Teflon Tape

2. Screw the adaptor onto the valve and tighten it using a pipe wrench. Ensure two of the screw holes of the adaptor (used to fasten the Hydran 201Ti's heating plate) are level (horizontal); see Figure 6-5 on page 6-22.

WARNING The H201Ti can be installed either on a horizontal (recommended) or vertical valve. If installed vertically, read the points listed on page 5-11.

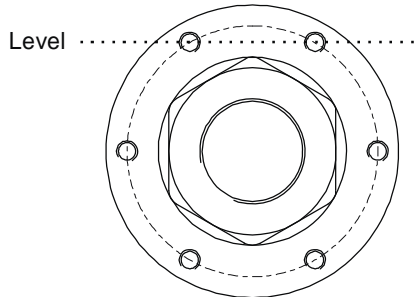

Figure 6-5 - Ensure Two Screw Holes of the Adaptor Are Level

6.3.5 Installing the Hydran 201 Sensor

1. Cover the sensor's threads with Teflon tape (see Figure 6-4 on page 6-21).

WARNING Use only Teflon tape to seal the threads of both the adaptor and H201 sensor. Wrap at least 4 to 5 layers of tape around the threads.

2. Slightly loosen the sensor's bleed screw, using the supplied 5/32-in Allen key.
3. Screw the sensor manually onto the adaptor.
4. Tighten the sensor using General Electric Canada's Hydran 201TW tube wrench (see Figure 5-4 on page 5-4) or a strap wrench. *Do not use a pipe wrench.* Do not use excessive force when tightening the H201 sensor onto the valve.

Note: If the H201 sensor is installed horizontally, ensure the bleed screw is on top (at the "12 o'clock" position); see Figure 6-6 on page 6-23.

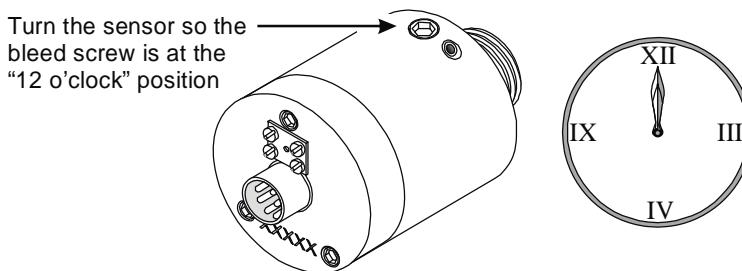

Figure 6-6 - The Bleed Screw Must Be on Top, at the 12 O'clock Position

5. Ensure the bleed screw is in place. *Do not* tighten it now.

6.3.6 Opening the Valve

WARNING

This step should be performed according to company regulations. Proceed carefully to avoid introducing air into the transformer. Use a bucket to collect the oil.

1. Using the supplied 5/32-in Allen key, fully close the sensor's bleed screw and then open it *1/8 of turn*.
2. Slowly open the transformer valve until oil leaks out of the sensor's sampling port (see Figure 6-7 on page 6-24).
3. When there are *no more air bubbles* present in the oil, shut the bleed screw tightly.
4. Open the valve completely.
5. Wipe all traces of oil from the sensor.

WARNING

Do not use any solvent.

6. Inspect the adaptor and sensor for oil leaks.
7. Dispose of the collected oil according to company standards.

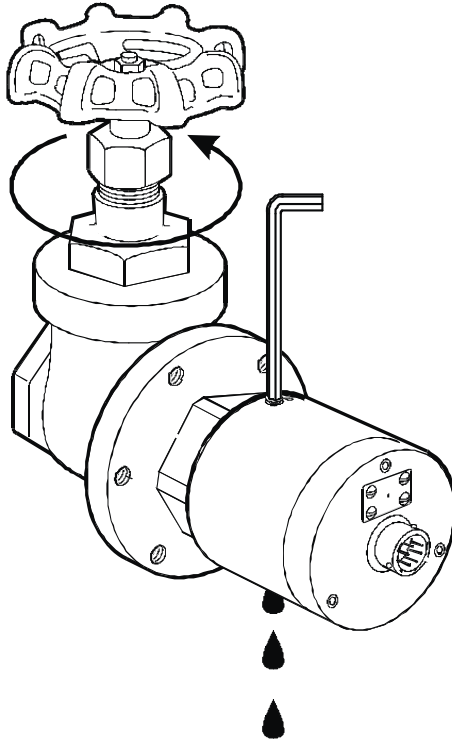

Figure 6-7 - Purging Air From the Hydran 201 Sensor

6.3.7 Fastening the Hydran 201Ti to the Brass Adaptor

1. Using the supplied 3/16-in Allen key, fasten the H201Ti's heating plate to the brass adaptor with the six 1/4-28 cap screws. See Figure 6-8 on page 6-25.

WARNING Be careful not to squeeze the nearby electrical wires between the lockwashers and the heating plate or not to damage the supervisory link (and analog output) termination board.

Note: When the H201Ti is installed horizontally, the terminals must be facing up and located under the sensor. Also, ensure the bleed screw and sampling port remain easy to access.

2. Plug the twist-lock female connector of the sensor cable to the male connector behind the Hydran 201 sensor.

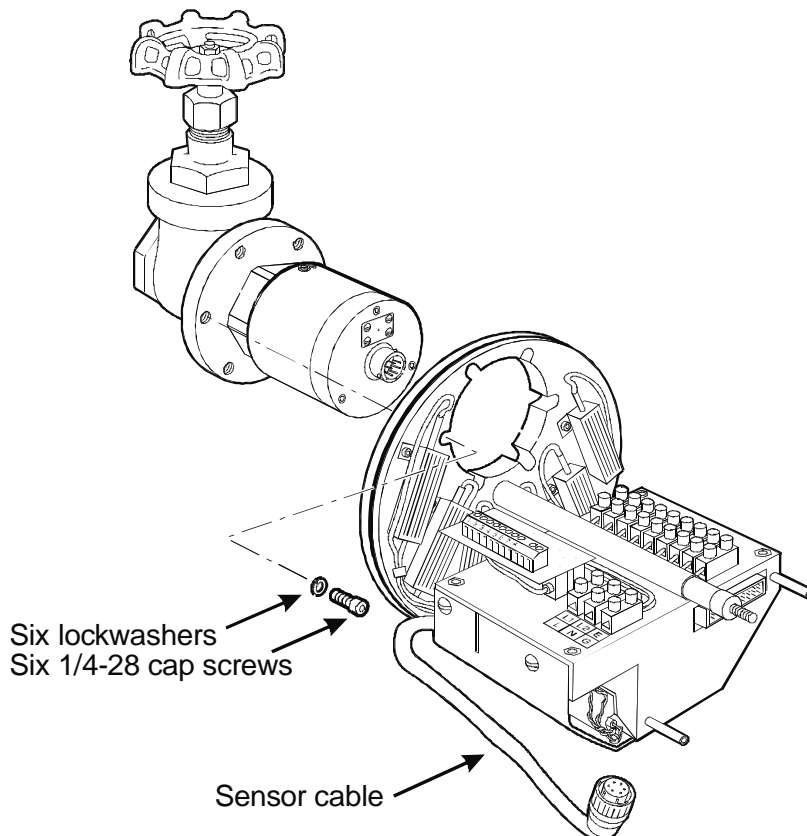

Figure 6-8 - Fastening the Heating Plate to the Brass Adaptor

6.3.8 Installing the Cable Conduits

Note the following considerations prior to installing:

- All cables connected to the Hydran 201Ti must be run through steel conduits. Otherwise, armored cables can be used.

WARNING

All metallic conduits or cable shields must be connected to the ground at one point.

- Flexible rather than rigid conduits should be used near the H201Ti to ease installation and servicing.

- Conduits, or cable armors, should be made of steel to shield against magnetic fields.
- Nonconducting conduit fittings (made of plastic, for example) can be used on the connection box if ground loops through the conduits may cause problems (for example, if the transformer tank is grounded at a single point and monitored continuously for tank-to-ground currents).

The procedure is as follows:

1. Remove the cover from the connection box located under the brass adaptor.
2. As required, install one or two watertight conduit fittings (not supplied) onto the connection box.
 - One conduit is used to run the supervisory link cable (which connects the H201Ti to the Hydran 201Ci Controller) and, if used, the cable of the H201Ti's analog output.
 - One conduit is used to run the power supply cable and, if used, the cable of the H201Ti's alarm contacts.
3. Mount a conduit to each fitting.

Note: The ac power to the H201Ti can be supplied from the H201Ci-1 Controller (via terminals 4 to 6 of the main terminal block) or from a different source. The H201Ci-C does not have terminals used to supply power to the H201Ti.

4. Ground the conduits and/or cable shields at some point. Follow the company regulations meticulously.

WARNING

The H201Ti must always be grounded, even if the transformer tank is grounded at a single point and monitored for tank-to-ground currents.

6.3.9 Installing the Supervisory Link and Analog Output Cable

Note the following considerations prior to installing:

- The supervisory link cable is supplied only when the Hydran 201Ti is part of a Hydran 201R Model *i* or is ordered with a Hydran 201Ci-C Controller.
- A supervisory link cable connected to a H201Ci-1 requires three twisted pairs and an overall shield.

- A supervisory link cable connected to a H201Ci-C requires two twisted pairs and an overall shield.
- If, for special considerations, the H201Ti's analog output is used, select a cable with characteristics similar to the supervisory link cable but with an additional pair of wires.

The procedure is as follows:

1. Run the supervisory link cable into the conduit up to the H201Ci Controller, where it will be connected later.
2. Ensure all wires are identified.
3. Connect the cable wires and shield to the H201Ti's supervisory link (and analog output) termination board. For wiring details, see Table D-6 on page D-3.

WARNING

The H201Ti's operation may be affected if wires are not connected correctly. Be careful when installing and inserting each wire. Be sure to insert all strands in the terminal; strands that touch two terminals cause problems. Strip each wire to a maximum of 8 mm before installing it. Do not leave trims of metallic strands inside the H201Ti's enclosure.

4. Connect the analog output wires to the SCADA system.

6.3.10 Installing the Alarms Cable (Facultative)

If the Hydran 201Ti's alarms are used, proceed as follows:

1. Run the alarms cable through the second conduit up to the H201Ti.
2. Connect the cable to the H201Ti's Alarm Contacts 9-Terminal Block (item 12 in Figure 2-5 on page 2-9). For wiring details, see Table D-2 on page D-1.
3. Connect the cable to the SCADA system.

6.3.11 Installing the ac Power Supply Cable

1. Run the three-wire ac power supply cable into the second conduit up to the Hydran 201Ti.

2. Connect the cable to the H201Ti's terminals **L1/L**, **L2/N** and **E/G**. For wiring details, see Table D-1 on page D-1.
3. Connect the other end of the cable to the power source.

Note: The earth/ground terminal (E/G) must be connected to the power source ground (green wire) or directly to the transformer tank. See the special considerations regarding grounding at the beginning of Section 6.3.8 on page 6-25.

WARNING

Never perform high-voltage tests (mega-ohm measurements using a Megger* instrument) on cables connected to a H201Ti or a Hydran 201Ci Controller. Never apply high voltages to the components of a Hydran 201i System, as they are equipped with surge protection devices that could be damaged by Megger* tests.

6.3.12 Installing the CPU Module

1. Align and carefully insert the CPU module on the central post of the Hydran 201Ti until the connector (at the back of the module) is completely inserted in the mating connector.
2. Fasten the module with the two 6-32 screws (see Figure 6-9 on page 6-29).

WARNING

When fastening the CPU module, ensure not to bend the pins of the connector located between the CPU and I/O modules.

6.3.13 Verifying the Hydran 201Ti Operation

1. Power up the H201Ti.
2. Perform the procedure described in Section 6.2.2 on page 6-7.

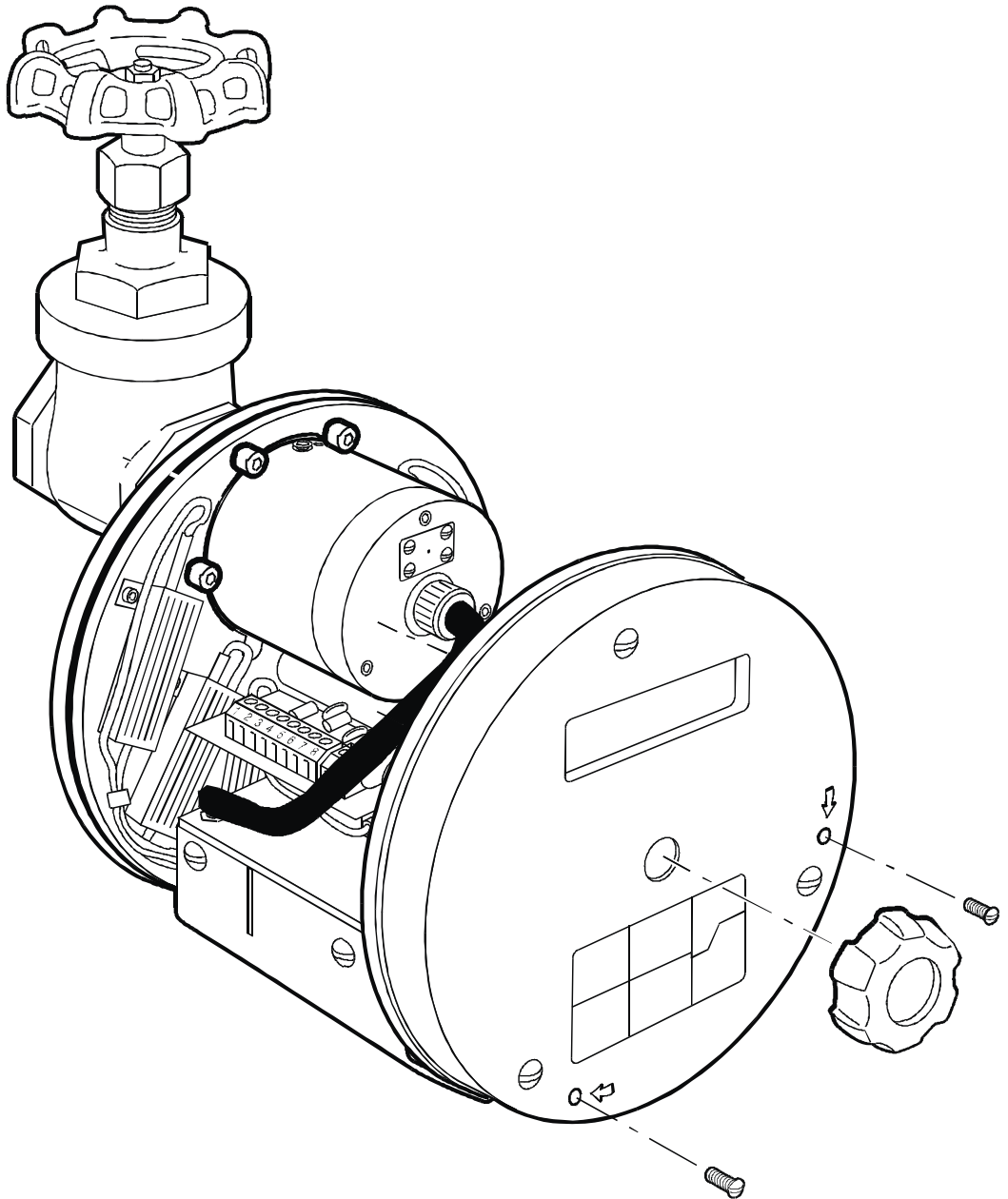

Figure 6-9 - Installing the CPU Module

6.4 CONFIGURING THE HYDRAN 201Ti

The H201Ti can be configured using either its keypad or a host computer running the Hydran Host software. It is recommended to use the Hydran Host software because the configuration task is much easier. For details, see the *Hydran Host Software Manual*.

The H201Ti's user interface is described thoroughly in Section 4.1 on page 4-1. The parameter verification detailed in the following pages is written for those who are using the H201Ti's keypad.

Note: The values indicated in this Section are only given as an indication and may differ from customer requirements. The value of the various parameters should be decided during the planning stage of the installation. Ensure to verify all parameters.

6.4.1 Setting the Communication Parameters for the Hydran Host Software

Proceed as follows in order to use a host computer:

1. Connect the supplied RS-232 cable to the Hydran 201Ti's DB-9 male RS-232 connector (see item 5 in Figure 2-2 on page 2-5), located at the back of the CPU module.
2. Using the H201Ti's keypad, access the submenu **H201Ti V2.2x;Communication**.
3. Press **ENTER** to access the parameter **CommChannel** (communication channel).
4. Set the parameter **CommChannel** to **H201Ti-DB-9**.
5. Press **ENTER** to confirm the modification.
6. Press **END**.

*Note: Do not change the parameter **DefaultChannel**. The H201Ti returns automatically to the default channel if there is no communication during five minutes.*

6.4.2 Verifying and Setting Historical Data File Parameters

For details on the parameters and commands in the submenu **History**, see Section 4.5.1 on page 4-12.

1. Access the submenu **H201Ti V2.2x;History**.
2. Access the submenu **History;HistorySetup**.
3. Verify and set, as required, the Short Term logging rate and the four Long Term logging hours.
4. Access **History;Clear Short Term**.
5. Press **ENTER** twice to erase the contents of the historic data file Short Term.
6. Access **History;Clear Long Term**.
7. Press **ENTER** twice to erase the contents of the historic data file Long Term.

WARNING

Do not erase the contents of the historic data file Events, in order to keep a record of changes performed during the present configuration.

6.4.3 Verifying and Setting Gas and Trend Alarm Parameters

For details on the parameters and commands in the submenu **Gas**, see Section 4.5.2 on page 4-16. The operation of the relays and alarms is explained in detail in Chapter 10.

1. Wait a minimum of 30 minutes after powering up the Hydran 201Ti or until the level of dissolved gases in oil read by the H201Ti is stable.
2. Access the submenu **H201Ti V2.2x;Gas**.
3. Verify and set, as required, the 15 parameters (alarm set points and periods). Do not set the parameters **HourlyTr Period** and **DailyTr Period**.

6.4.4 Resetting the Hourly Trend, Daily Trend and Period B

The hourly trend, daily trend and **Period B** are reset by changing the value of their *period* and then restoring them to their initial value after five minutes. Proceed as follows:

1. In the submenu **H201Ti V2.2x;Gas**, access the submenu **Gas;HourlyTrend**.
2. Access the parameter **HourlyTr Period**.
3. Set this parameter to 1 hour.
4. In the submenu **H201Ti V2.2x;Gas**, access the submenu **Gas;DailyTrend**.
5. Access the parameter **DailyTr Period**.
6. Set this parameter to 1 day.
7. In the submenu **H201Ti V2.2x;Temperature**, access the submenu **Temperature;DynOil Sampl**.
8. Access the parameter **Period B**.
9. Set this parameter to 0 hour.
10. Wait five minutes and set these parameters to their default value:
 - **HourlyTr Period** to 24 hours
 - **DailyTr Period** to 30 days
 - **Period B** to 24 hours

For details on trend computations and reset, see Section 10.4.2 on page 10-11.

6.4.5 Verifying and Setting the Temperature Parameters of the Hydran 201 Sensor

For details on the parameters and commands in the submenu **Temperature**, see Section 4.5.3 on page 4-17.

1. Access the submenu **H201Ti V2.2x;Temperature**.

2. Verify and set, as required, all parameters except **Period B**.

6.4.6 Verifying the Hydran 201 Sensor and Its Parameters

For details on the parameters and commands in the submenu **Service**, see Section 4.5.4 on page 4-18.

1. Access the submenu **H201Ti V2.2x;Service**.
2. Access the submenu **Service;SensorCal Data**.
3. Ensure the displayed serial number, the ten parameters (**B**, **M**, **N**, **S** and **A1** to **A6**) and the checksum all correspond to the values on the Test Certificate and Data Sheet (for an example, see Figure 6-1 on page 6-4).
4. Access the command **Force Sensor Test**.
5. Push **ENTER**. The message **AreYou Sure?;PressEnter..** is now displayed.
6. Push **ENTER** again to confirm.
7. When asked to enter the password #1 (**1253**), use the **UP** and **ENTER** keys.
8. The message **Please wait...** appears, the test is executed (during a four-second countdown), and the Hydran 201Ti's display should indicate the message **Good**. If another message is displayed, see Section 12.1.3 on page 12-2.

Note: The keypad cannot be used for two minutes following a sensor test. Wait before resuming the configuration.

6.4.7 Verifying and Setting the Battery Alarm Parameters

1. Access the submenu **H201Ti V2.2x;Service**.
2. Access the submenu **Service;Battery**.
3. Verify the battery voltage (**Battery**). For details, see Section 6.1.4 on page 6-5.
4. Verify and set, as required, the three alarm parameters.

6.4.8 Logging the Values of the Service Data

1. Access the submenu **H201Ti V2.2x;Service**.
2. Access the submenu **Service;ServiceData**.
3. Write down the value of each parameter.

6.4.9 Verifying and Setting the Date and Time

For details on the parameters and commands in the submenu **Date&Time**, see Section 4.5.5 on page 4-21.

1. Access the submenu **H201Ti V2.2x;Date&Time**.
2. If required, set the parameters **Year**, **Month**, **Day**, **Hour** and **Minutes** to local values.

6.4.10 Verifying and Setting the Communication Parameters

For details on the parameters and commands in the submenu **Communication**, see Section 4.5.6 on page 4-21.

1. Access the submenu **H201Ti V2.2x;Communication**.
2. Verify and set, as required, the six communication parameters (which can only be accessed from the Hydran 201Ti's keypad). Note the following considerations:
 - **Gas Monitor ID** (identification number of the H201Ti): At least one H201Ti in the local network must be set to an identification number from 1 to 5 inclusively. Each H201Ti in the local network must have an exclusive number from 1 to 254.
 - **PowerStat. ID** (identification number of the power station): All H201Ti's in the local network (power station) must be set to the same **PowerStat. ID** value. This number can vary from 1 to 9999.
3. To continue the installation using a host computer, run the Hydran Host software to define a local network using these identification numbers. See the *Hydran Host Software Manual*.

6.4.11 Verifying and Setting the Operation Mode of the Alarm Relays

For details on the parameters and commands in the submenu **Relays/Analog**, see Section 4.5.7 on page 4-23. For details on relays, see Section 10.2 on page 10-4.

1. Access the submenu **H201Ti V2.2x;Relays/Analog**.
2. Verify and set, as required, the three **RelayMode** parameters.

6.4.12 Verifying and Setting the Fail Alarm Conditions

1. Access the submenu **SysOK Relay;FaultTrig**.
2. Verify and set, as required, the 16 trigger conditions of the Hydran 201Ti's fail alarm relay.

Note: An asterisk at the end of the display's bottom line indicates that the parameter is turned on (the fail alarm is triggered if this condition is detected). A space indicates that the parameter is off.

6.4.13 Verifying and Setting the Operation Mode of the Analog Output and TDM Signal

1. Access the submenu **H201Ti V2.2x;Relays/Analog**.
2. Verify and set, as required, the parameters **AnalogMode** and **TDM Mode**.

6.4.14 Conclusion

If the configuration has been performed using a host computer connected to the DB-9 connector located at the back of the CPU module, proceed as follows:

1. Access the submenu **Communication**.
2. Set the parameter **CommChannel** (communication channel) to **Supervisory Link**.
3. Press **END** to return to the Main Display mode.

The Hydran 201Ti configuration is now completed.

6.5 FASTENING THE HYDRAN 201Ti'S COVER

Replace the H201Ti's aluminum cover as soon as the installation is completed.

1. Ensure the rubber washer is present on the central post.
2. Slide the cover over the H201Ti.
3. Fasten the cover by tightening the knob. The breathing membrane must be facing down (at the "6 o'clock" position) if the H201Ti is installed horizontally.

If connected to a Hydran 201Ci Controller, the H201Ti will later be used to test this Controller.

6.6 COMMISSIONING

1. Wait at least two hours for the Hydran 201Ti to stabilize. The Hydran 201Ci Controller(s) can be installed during this time.
2. Verify the H201Ti's accuracy by comparing its readings with a recent dissolved gas analysis (DGA).
3. If necessary and with the permission of the user, set the alarm set points again, this time according to the current level of dissolved gases in oil. See Section 10.4.1 on page 10-9.

The installation of the H201Ti is now completed. If properly installed and maintained, the H201Ti provides many years of trouble-free service.

6.7 OTHER INSTALLATIONS

To install other components of the Hydran 201i System, please consult the following parts of this manual:

- Hydran 201Ci-C: See Chapter 7.
- Hydran 201Ci-1: See Chapter 8.
- Local network: See Section 9.5 on page 9-8.
- Optional modem: See Section 9.6 on page 9-11.

Hydran 201Ci-C Installation

Please read the following Sections before proceeding with the installation:

- General warnings, in Section 5.1 on page 5-1
- Installation overview, in Section 5.2 on page 5-7

7.1 INCOMING INSPECTION AND VERIFICATION

It is strongly recommended to verify the operation of the Hydran 201Ti's and Hydran 201Ci Controllers before their installation. This verification also confirms that no damage occurred during shipping and allows the user to become familiar with the Hydran 201i System. The Hydran 201Ci-C installation procedure is described in Section 7.3 on page 7-6.

7.1.1 Receiving and Unpacking

Upon receipt, the shipping box contains one pre-assembled Hydran 201Ci-C.

1. Open the shipping box.
2. Remove the Test Certificate and Data Sheet (for an example, see Figure 6-1 on page 6-4).
3. Carefully remove the H201Ci-C from the box.

Note: Keep the packing material for storage or further shipment of the H201Ci-C.

7.1.2 Inspecting

Verify the Hydran 201Ci-C completely as outlined below.

1. Inspect the enclosure for any visual damage (bump, scratch or others).
2. Open the enclosure door using a flat-blade screwdriver.

3. Verify the ac power supply voltage (indicated on the label inside the H201Ci-C, near the power supply terminal block) corresponds to the power source voltage and the value on the Test Certificate and Data Sheet (for an example, see Figure 6-1 on page 6-4). There are two possibilities:
 - 115 V, corresponding to a 90–132 Vac range from 47 to 63 Hz
 - 230 V, corresponding to a 180–264 Vac range from 47 to 63 Hz
4. Ensure the H201Ci-C's serial number (indicated on the right internal side of the enclosure wall or on the back of the door) corresponds to those indicated on the Test Certificate and Data Sheet and on the shipping box.
5. Report any discrepancy to the company supervisor and the General Electric Canada Customer Service (the coordinates can be found at the bottom of page ii).

Note: Never return equipment without first contacting the General Electric Canada Customer Service.

7.1.3 Storage

If the Hydran 201Ci-C is not installed immediately, it is strongly recommended to store it in its original shipping box in a safe place.

Storage should be at a temperature between 5 and 45 °C (41 and 113 °F) and a non-condensing, relative humidity between 5 and 95 %; if these limits are to be exceeded, please contact the General Electric Canada Customer Service (the coordinates can be found at the bottom of page ii). These restrictions do not apply to transportation.

7.2 VERIFICATION OF OPERATION PRIOR TO INSTALLATION

It is strongly recommended to verify the operation of the Hydran 201Ci-C Controller(s) before installation in the field. The verification confirms that no damage occurred during shipping and allows the user to become familiar with the H201Ci-C.

7.2.1 Preparation

To verify its operation, the Hydran 201Ci-C must first be connected to at least one functional Hydran 201Ti via a supervisory link cable. One end of this cable is already connected to the H201Ti. For details on commissioning the H201Ti('s), see Chapter 6.

Proceed as follows:

1. Connect a three-wire power cord to the ac Power 3-Terminal Block on the first H201Ti (item 8 in Figure 2-4 on page 2-8): The live side to **L1/L**, the other side to **L2/N**, and the ground to **E/G**. For additional wiring details, see Table D-1 on page D-1.
2. Connect the second end of the two-pair supervisory link cable coming out of the H201Ti to the main terminal block on the H201Ci-C (item 5 in Figure 3-2 on page 3-3).
3. Power On the H201Ti.
4. Ensure the H201Ti is operating normally and no gas or fail alarms are present, by looking at the small LED indicators on the right side of the I/O module (refer to Section 2.4.6.3 on page 2-11).
5. Repeat the steps 1 to 4 above until all H201Ti's are connected to the H201Ci-C.
6. Connect a power cord to the ac Supply Connector on the H201Ci-C (item 19 in Figure 3-3 on page 3-5).
7. Power On the H201Ci-C.

WARNING

***ELECTRICAL SHOCK HAZARD.* Turn off the electric power at the fuse box or service panel before making any electrical connections, and ensure a proper ground connection is made before connecting line voltage. Failure to do so can result in property damage, personal injury and/or death.**

8. Repeat the steps 1 to 7 above until all H201Ci-C's are fed.

7.2.2 Initial Observations

1. On each Hydran 201Ci-C, verify the Supervisory Link Supply indicator (green, DS12; item 15 in Figure 3-3 on page 3-5) is lit.

2. On each Hydran 201Ci-C, look at the Heater indicator (yellow, DS8; item 13 in Figure 3-3 on page 3-5):
 - The LED must initially be lit if the ambient temperature is below approximately 25 °C (77 °F).
 - After a while, the LED must flash as the enclosure temperature reaches the above set point.
 - The LED must remain off if the ambient temperature exceeds the set point.

7.2.3 Verification of RS-232 and RS-485 Communications

If your installation includes only one Hydran 201i System and if it communicates with the host computer running the Hydran Host software, you must verify the RS-232 link. If your installation includes several Hydran 201i Systems forming a local network, you must also verify the RS-485 local network link. Proceed as follows:

1. Put all Hydran 201Ci-C's in a common network by connecting the RS-485 LAN cable from one H201Ci-C's RS-485 LAN connector (J11; item 11 in Figure 3-3 on page 3-5) to the next in a daisy-chain fashion. Refer to Chapter 9.
2. Ensure all Hydran 201Ti's and all H201Ci-C's are connected together.
3. Connect the DB-9 male RS-232 connector (item 2 in Figure 3-2 on page 3-3) or the RS-232 Computer Port connector (J10; item 7 in Figure 3-3 on page 3-5) of any H201Ci-C on the network to your PC's RS-232 port. For wiring details, see Table D-7 on page D-4.
4. In the **Communication** submenu of each H201Ti, write down the current settings, in order to be able to restore them.
5. Set the parameters as follows:
 - **Comm Channel = Supervisory Link**
 - **DefaultChannel = Supervisory Link**
 - **Baud Rate = 9600**
 - **Gas Monitor ID = 1**

WARNING

At least one H201Ti in a local network must be set with an identification number (Gas Monitor ID) from 1 to 5 inclusively. Each H201Ti in a local network must have an exclusive number from 1 to 254. The H201Ti's are normally shipped with the Gas Monitor ID number set to 1.

6. Start the Hydran Host software on the PC. See the *Hydran Host Software Manual* for more information.
7. In the **Network Settings** menu of the Hydran Host software, set the network configuration to the **Gas Monitor ID** numbers that were assigned to each H201Ti in the step 5 above.
8. In the **Setup** menu of the Hydran Host software, check the communication by accessing the H201Ti('s). The Communications Status indicator (yellow, DS6; item 23 in Figure 3-3 on page 3-5) flickers when the PC communicates with the H201Ti('s).
9. In the **Network Survey** window of the Hydran Host software, verify the PC is communicating with each H201Ti (there are no **Does not answer** warnings in the **Status** text boxes).
10. If the communication cannot be established:
 - Ensure the H201Ti identification numbers entered in the Hydran Host software correspond to those entered in each H201Ti (**Gas Monitor ID** parameters).
 - Verify the wiring of all supervisory link cables.
 - Verify the wiring of the RS-485 local network link.
 - Finally, disconnect the RS-485 link cable from all H201Ci's and reinstall the local network, one H201Ci at a time.
11. In the **Relays/Analog** window of the Hydran Host software, change the **Relay Mode** of each relay from **Force OFF** to **Force ON** and back; this should change the state of the alarm relays from **On** to **Off**, thus confirming good communications through the supervisory links. Following each step:
 - Verify the state of the **H**, **HH** and **OK** LED's on each H201Ti.

- Ensure the Communications Status indicator (yellow, DS6; item 23 in Figure 3-3 on page 3-5) flickers inside each H201Ci-C when the host computer communicates with any H201Ti of the H201Ci-C.
12. When the test is completed, in the **Relays/Analog** window of the Hydran Host software, restore the **Relay Mode** of each relay to **Normal**.
 13. Disconnect all communication cables (supervisory links, RS-485 LAN and RS-232 to the PC).
 14. Restore the original communication settings in each H201Ti as noted in the step 4 above.

7.2.4 Completing the Verification

This completes the incoming verification of the Hydran 201Ci-C.

1. Disconnect all the H201Ti's from the power outlets.
2. Disconnect all the H201Ci-C's from the power outlets.
3. Remove all supply cables.
4. Remove all communication cables.
5. Store the H201Ti's and the H201Ci-C's in their respective boxes, ready for installation.
6. If the H201Ti's are not installed immediately, refer to Section 6.1.4 on page 6-5.
7. If the H201Ci-C's are not installed immediately, refer to Section 7.1.3 on page 7-2.

7.3 INSTALLATION

This Section explains how to install the Hydran 201Ci-C Controller.

WARNING

Read all the warnings and recommendations in Section 5.1 on page 5-1 before proceeding with the installation.

Note: It is strongly recommended that the operation of all H201Ti's and H201Ci Controllers be verified before installation of the equipment in the field. Verification also allows the user to become familiar with the Hydran 201i System.

WARNING

All procedures in this manual must be strictly adhered to. Any deviation from these could cause irreversible damages to the transformer being monitored and/or the Hydran 201i System, and could lead to property damage, personal injury and/or death. Installation and maintenance of the Hydran 201i System must be carried out by qualified personnel only.

The H201Ci-C is equipped with a Type NEMA 4X enclosure and internal heating; it can thus be installed outdoor.

7.3.1 Verifying the ac Power Supply Voltage and the Serial Numbers

Ensure steps 3 and 4 on page 7-2 have been performed.

7.3.2 Installing the Enclosure

Prepare the installation location of the Hydran 201Ci-C. Read the recommendations in Section 5.2.3 on page 5-12.

The H201Ci-C must be mounted on a vibration-free structure. If vibrations are present, use vibration-absorbing rubber pads (Figure 1-5 on page 1-9), which can be purchased from General Electric Canada.

7.3.3 Installing the Cable Conduits

Note the following considerations prior to installing:

- All cables connected to the Hydran 201Ci-C must be run through steel conduits. Otherwise, armored cables can be used.
- Flexible rather than rigid conduits should be used near the H201Ci-C to ease installation and servicing.
- Conduits, or cable armors, should be made of steel to shield against magnetic fields.

The procedure is as follows:

1. Remove the rubber plugs from the required openings of the H201Ci-C enclosure.
2. For each cable being used, install a standard, watertight conduit fitting (not supplied). Up to eight conduits may be installed (supervisory links, ac power supply).
3. Mount a conduit to each fitting.
4. Ground the conduits and/or cable shields at some point. Follow the company regulations meticulously.

7.3.4 Installing the Supervisory Link Cables

Note: The supervisory link cables have already been run into conduits up to the Hydran 201Ci-C if the installation of the Hydran 201Ti's is completed (see Section 6.3.9 on page 6-26).

1. If required, trim the excess length from the end of the supervisory link cables to be wired into the H201Ci-C.

Note: The total maximum length of all supervisory link cables connected to one H201Ci-C is 1,200 m (4,000 ft).

2. Ensure the four wires of each cable have been labelled (for identification purposes) at both ends.
3. Connect the wires and shield of one cable to one of the four H201Ci-C's termination boards. For wiring details, see Table D-8 on page D-5.

Note: The shield is grounded through a capacitor at the H201Ti end to protect against radiofrequency interference. Shields must also be directly grounded at the H201Ci-C's termination board.

WARNING

The H201Ci-C's operation may be affected if wires are not connected correctly. Be careful when installing and inserting each wire. Be sure to insert all strands in the terminal; strands that touch two terminals cause problems. Strip each wire to a maximum of 8 mm before installing it. Do not leave trims of metallic strands inside the H201Ci-C's enclosure.

4. Repeat the step 3 above for each supervisory link cable (the installation order is not important).

7.3.5 Installing the ac Power Supply Cable

1. Run the three-wire ac power supply cable through a conduit up to the Hydran 201Ci-C.
2. Connect the cable to the H201Ci-C's **L1/L** and **L2/N** terminals, and connect the **E/G** wire to the enclosure chassis. For wiring details, see Table D-8 on page D-5.
3. Connect the other end of the cable to the power source.

Note: The earth/ground terminal (E/G) must be connected.

WARNING

Never perform high-voltage tests (mega-ohm measurements using a Megger* instrument) on cables connected to a Hydran 201Ti or a Hydran 201Ci Controller. Never apply high voltages to the components of a Hydran 201i System, as they are equipped with surge protection devices that could be damaged by Megger* tests.

7.3.6 Verifying the Operation

Proceed as described in Section 7.2.1 on page 7-2 and Section 7.2.2 on page 7-3.

7.3.7 Verifying the Supervisory Link Communications

Verify communications between the Hydran 201Ci-C and the Hydran 201Ti('s) using a host computer running the Hydran Host software. Proceed as described in Section 7.2.3 on page 7-4 and Section 6.2.9 on page 6-15.

7.3.8 Conclusion

The installation of the Hydran 201Ci-C is now completed.

7.4 OTHER INSTALLATIONS

To install other components of the Hydran 201i System, please consult the following Sections:

- Local network: See Section 9.5 on page 9-8.
- Optional modem: See Section 9.6 on page 9-11.

Hydran 201Ci-1 Installation

Please read the following Sections before proceeding with the installation:

- General warnings, in Section 5.1 on page 5-1
- Installation overview, in Section 5.2 on page 5-7

8.1 INCOMING INSPECTION AND VERIFICATION

It is strongly recommended to verify the operation of the Hydran 201Ti's and Hydran 201Ci Controllers before their installation. This verification also confirms that no damage occurred during shipping and allows the user to become familiar with the Hydran 201R Model *i*. The Hydran 201Ci-1 installation procedure is described in Section 8.3 on page 8-11.

8.1.1 Receiving and Unpacking

Upon receipt, the shipping box contains one pre-assembled Hydran 201Ci-1.

1. Open the shipping box.
2. Remove the Test Certificate and Data Sheet (for an example, see Figure 6-1 on page 6-4).
3. Carefully remove the H201Ci-1 from the box.

Note: Keep the packing material for storage or further shipment of the H201Ci-1.

8.1.2 Inspecting

Verify the Hydran 201Ci-1 completely as outlined below.

1. Inspect the enclosure for any visual damage (bump, scratch or others).
2. Open the enclosure door using a flat-blade screwdriver.

3. Verify the ac power supply voltage (indicated on the label inside the H201Ci-1, near the main terminal block) corresponds to the power source voltage and the value on the Test Certificate and Data Sheet (for an example, see Figure 6-1 on page 6-4). There are two possibilities:
 - 115 V, corresponding to a 90–132 Vac range from 47 to 63 Hz
 - 230 V, corresponding to a 180–264 Vac range from 47 to 63 Hz
4. Ensure the H201Ci-1's serial number (indicated on the right internal side of the enclosure wall or on the back of the door) corresponds to those indicated on the Test Certificate and Data Sheet and on the shipping box.
5. Report any discrepancy to the company supervisor and the General Electric Canada Customer Service (the coordinates can be found at the bottom of page ii).

Note: Never return equipment without first contacting the General Electric Canada Customer Service.

8.1.3 Storage

If the Hydran 201Ci-1 is not installed immediately, it is strongly recommended to store it in its original shipping box in a safe place. Ensure to cover the door-mounted push-buttons with the protective caps.

Storage should be at a temperature between 5 and 45 °C (41 and 113 °F) and a non-condensing, relative humidity between 5 and 95 %; if these limits are to be exceeded, please contact the General Electric Canada Customer Service (the coordinates can be found at the bottom of page ii). These restrictions do not apply to transportation.

8.2 VERIFICATION OF OPERATION PRIOR TO INSTALLATION

It is strongly recommended to verify the operation of the Hydran 201Ci-1 Controller before installation in the field. The verification confirms that no damage occurred during shipping and allows the user to become familiar with the H201Ci-1.

8.2.1 Preparation

To verify its operation, the Hydran 201*Ci-1* must first be connected to a functional Hydran 201*Ti* via a supervisory link cable. One end of this cable is already connected to the H201*Ti*. For details on commissioning the H201*Ti*, see Chapter 6. Proceed as follows:

1. Connect a three-wire power cord to the ac Power 3-Terminal Block on the H201*Ti* (item 8 in Figure 2-4 on page 2-8): The live side to **L1/L**, the other side to **L2/N**, and the ground to **E/G**. For additional wiring details, see Table D-1 on page D-1.
2. Connect the second end of the three-pair supervisory link cable coming out of the H201*Ti* to the main terminal block on the H201*Ci-1* (item 6 in Figure 3-6 on page 3-11).
3. Power On the H201*Ti*.
4. Ensure the H201*Ti* is operating normally and no gas or fail alarms are present, by looking at the small LED indicators on the right side of the I/O module (refer to Section 2.4.6.3 on page 2-11).
5. Connect a power cord to the terminals 1 and 2 on the main terminal block of the H201*Ci-1* (item 6 in Figure 3-6 on page 3-11), and connect the **E/G** wire to the enclosure chassis.
6. Power On the H201*Ci-1*.

8.2.2 Initial Observations

1. Verify the Hydran 201*Ci-1*'s display is not blank. If it remains blank, the possible causes are as follows:
 - If the fail alarm is triggered, read the alarm message on the Hydran 201*Ti*'s display to identify the cause of the alarm. Then see Chapter 12.
 - Verify the connections at both ends of the supervisory link cable.
 - Verify the fuse(s) and the ac power supply of the H201*Ci-1* and H201*Ti*.
 - Verify the operation of the H201*Ci-1*'s display.
2. Verify the H201*Ci-1*'s display shows the same ppm value as the H201*Ti*'s scrolling gas level display. A discrepancy of ± 2 ppm is acceptable.

3. Inside the H201Ci-1, verify the Supervisory Link Supply indicator (green, DS12; item 17 in Figure 3-7 on page 3-12) is lit.
4. Inside the H201Ci-1, look at the Heater indicator (yellow, DS8; item 13 in Figure 3-7 on page 3-12):
 - The LED must initially be lit if the ambient temperature is below approximately 25 °C (77 °F).
 - After a while, the LED must flash as the enclosure temperature reaches the above set point.
 - The LED must remain off if the ambient temperature exceeds the set point.
5. Since there are no alarm conditions present in the H201Ti, verify the following points on the H201Ci-1:
 - The Gas High alarm indicator of the door-mounted push-button **1** (item 2 in Figure 3-5 on page 3-9) is off.
 - The Gas High-High alarm indicator of the door-mounted push-button **2** (item 2 in Figure 3-5 on page 3-9) is off.
 - The Alarm 1 (Gas High) indicator (yellow, DS10; item 15 in Figure 3-7 on page 3-12) is off.
 - The Alarm 2 (Gas High-High) indicator (yellow, DS9; item 14 in Figure 3-7 on page 3-12) is off.
 - The System OK indicator (yellow, DS11; item 16 in Figure 3-7 on page 3-12) is lit.

8.2.3 Verifying the Analog Output

The Hydran 201Ci-1 is equipped with an isolated, analog 4–20 mA output. Table 4-7 on page 4-25 lists the electrical currents that should be generated and the values that should be displayed for each operation mode.

Proceed as follows:

1. Connect a dc digital ammeter with a 1 % accuracy and a 0.01 mA resolution to the main terminal block on the H201Ci-1 (item 6 in Figure 3-6 on page 3-11).
2. Connect the positive lead on the pin 17 of the main terminal block.
3. Connect the negative lead on the pin 18 of the main terminal block.

4. On the Hydran 201Ti's display, access the top of the extended menu by pushing **ENTER** twice (**History** appears).

Note: Once accessed, the extended menu times out after 30 minutes of keypad inactivity.

5. Push **DOWN** six times until **Relays/Analog** appears.
6. Access this menu by pushing **ENTER**.
7. Push **DOWN** until **TDM Pulse Out** appears.
8. Push **ENTER**.
9. Push **DOWN** until **TDM Out Mode** appears.
10. Push **ENTER**. The value should be **Normal**.
11. Modify the **TDM Out Mode** by pushing **CHANGE**.
12. When asked to enter the password #1 (**1253**), use the **UP**, **DOWN** and **ENTER** keys.
13. Use the **UP**, **DOWN** and **ENTER** keys to force the output to **0 %**.
14. Allow about one minute for the output to stabilize.
15. Verify the H201Ci-1's display reads 0 ± 2 ppm.
16. Verify the ammeter reads 4.00 ± 0.10 mA.
17. Use the **UP**, **DOWN** and **ENTER** keys to force the output to **50 %**.
18. Allow about one minute for the output to stabilize.
19. Verify the H201Ci-1's display reads 1000 ± 5 ppm.
20. Verify the ammeter reads 12.00 ± 0.20 mA.
21. Use the **UP**, **DOWN** and **ENTER** keys to force the output to **100 %**.
22. Allow about one minute for the output to stabilize.

23. Verify the H201Ci-1's display reads 1999 ppm.

*Note: The maximum value of the Hydran 201Ci-1's display scale is 1999 ppm. If the signal is over scale, the display indicates **1...** when the operation mode is set to **Force 100 %**.*

24. Verify the ammeter reads 20.00 ± 0.40 mA.

25. Use the **UP**, **DOWN** and **ENTER** keys to force the output to **Off**.

26. Verify that:

- The H201Ci-1's display is blank.
- The analog output drops to 0.00 ± 0.10 mA.
- The System OK indicator (yellow, DS11; item 16 in Figure 3-7 on page 3-12) is off.

27. Use the **UP**, **DOWN** and **ENTER** keys to return the output to **Normal**.

28. Verify the signal of the analog output returns to its former value.

29. When all is done, push **END**.

30. Disconnect the ammeter.

8.2.4 Verifying the Alarm Indicators and Relays

The steps described in this Section may be used during the Hydran 201Ci-1 verification, maintenance and troubleshooting procedures; certain steps may therefore not apply to your particular situation. Perform all procedures (from Section 8.2.4.1 on page 8-6 to Section 8.2.4.6 on page 8-9).

The alarm relays are verified by observing the LED's on the H201Ci-1's circuit board and by connecting an ohmmeter to the main terminal block on the H201Ci-1 (item 6 in Figure 3-6 on page 3-11).

8.2.4.1 Gas High Alarm

1. In the Hydran 201Ti, access the submenu **H201Ti V2.2x;Relays/Analog**.
2. Access the submenu **Relays/Analog;GasH Relay**.

3. Set the parameter **RelayMode** of the Gas High relay to **On**.
4. On the H201Ci-1, verify that:
 - The door-mounted **1** push-button indicator is lit.
 - The **Alarm 1** (Gas High) indicator (yellow, DS10; item 15 in Figure 3-7 on page 3-12) is lit.
 - The **Alarm 1** NO contact is closed.
 - The **Alarm 1** NC contact is open.
 - Other LED indicators and contacts have not changed from their previous state.
 - If connected, the supervisory control and data acquisition (SCADA) system has detected the alarm.

Note: Pushing the 1 push-button to acknowledge the gas alarm condition should not turn off the indicator since the condition has not cleared.

8.2.4.2 Gas High-High Alarm

1. Access the submenu **Relays/Analog;GasHH Relay**.
2. Set the parameter **RelayMode** of the Gas High-High relay to **On**.
3. On the H201Ci-1, verify that:
 - The door-mounted **2** push-button indicator is lit.
 - The **Alarm 2** (Gas High-High) indicator (yellow, DS9; item 14 in Figure 3-7 on page 3-12) is lit.
 - The **Alarm 2** NO contact is closed.
 - The **Alarm 2** NC contact is open.
 - Other LED indicators and contacts have not changed from their previous state.
 - If connected, the SCADA system has detected the alarm.

Note: Pushing the 2 push-button to acknowledge the gas alarm condition should not turn off the indicator since the condition has not cleared.

8.2.4.3 System Fault Alarm

1. Access submenu **Relays/Analog;SysOK Relay**.

2. Set the parameter **RelayMode** of the System Fault relay to **Off**.
3. On the H201Ci-1, verify that:
 - The display goes blank.
 - The two door-mounted push-button indicators (**1** and **2**) remain lit.
 - The **System OK** indicator (yellow, DS11; item 16 in Figure 3-7 on page 3-12) turns off.
 - The **System OK** alarm NO contact is open.
 - The **System OK** alarm NC contact is closed.
 - The gas alarm indicators (yellow DS9 and DS10) and contacts are restored to their normal state (no alarm condition).
 - If connected, the SCADA system has detected the alarm.

Note: Pushing both push-buttons to acknowledge the gas alarm conditions should turn off the indicators since the conditions are cleared during a system fault.

8.2.4.4 System Fault Alarm Cleared

1. Set the same **RelayMode** parameter to **Normal**.
2. On the H201Ci-1, verify that:
 - The H201Ci-1's display is functional again.
 - The two door-mounted push-button indicators (**1** and **2**) are lit because the gas alarm conditions still exist.
 - The **System OK** indicator (yellow, DS11; item 16 in Figure 3-7 on page 3-12) is lit.
 - The **System OK** alarm NO contact is closed.
 - The **System OK** alarm NC contact is open.
 - If connected, the SCADA system has detected the state change of the fail alarm relay.

Note: Pushing both push-buttons to acknowledge the gas alarm conditions should not turn off the indicators since the conditions are not cleared.

8.2.4.5 Gas Alarms Cleared

1. Access the submenu **Relays/Analog;GasH Relay**.
2. Set the parameter **RelayMode** of this relay to **Normal**.

3. Access the submenu **Relays/Analog;GasHH Relay**
4. Set the parameter **RelayMode** of this relay to **Normal**.
5. On the H201Ci-1, verify that:
 - The two door-mounted push-button indicators (**1** and **2**) remain lit.
 - The **Alarm 1** (Gas High) indicator (yellow, DS10; item 15 in Figure 3-7 on page 3-12) is off.
 - The **Alarm 2** (Gas High-High) indicator (yellow, DS9; item 14 in Figure 3-7 on page 3-12) is off.
 - The **System OK** indicator (yellow, DS11; item 16 in Figure 3-7 on page 3-12) is lit.
 - The **Alarm 1** NO contact is open.
 - The **Alarm 1** NC contact is closed.
 - The **Alarm 2** NO contact is open.
 - The **Alarm 2** NC contact is closed.
 - The **System OK** alarm NO contact is closed.
 - The **System OK** alarm NC contact is open.
 - If connected, the SCADA system has detected the state change of both gas alarm relays.

Note: Pushing both buttons to acknowledge the gas alarm conditions should turn off the indicators since the conditions have been cleared.

8.2.4.6 Conclusion

If necessary, set the parameter **RelayMode** of each alarm relay to their initial mode.

8.2.5 Verifying the RS-232 Communication

If your installation includes only one Hydran 201R Model *i* and if it communicates with the host computer running the Hydran Host software, you must verify the RS-232 link. Proceed as follows:

1. Connect the Hydran 201Ci-1's RS-232 Computer Port connector (J10; item 7 in Figure 3-7 on page 3-12) to your PC's RS-232 port. For wiring details, see Table D-13 on page D-11. For USB users, connect the Hydran 201Ci-1's USB Computer Port connector (J16; item 8 in Figure 3-7 on page 3-12).

2. In the **Communication** submenu of the Hydran 201Ti, write down the current settings, in order to be able to restore them.
3. Set the parameters as follows:
 - **Comm Channel = Supervisory Link**
 - **Default Channel = Supervisory Link**
 - **Baud Rate = 9600**
 - **Gas Monitor ID = 1**
4. To establish the communication, start the Hydran Host software on the PC. See the *Hydran Host Software Manual* for more information.
5. If the communication cannot be established:
 - Ensure the H201Ti identification number entered in the Hydran Host software corresponds to the one entered in the H201Ti (**Gas Monitor ID** parameter).
 - Verify the wiring of the supervisory link cable.
 - Verify the configuration of the Hydran Host software. See the *Hydran Host Software Manual* for more information.
6. Disconnect all communication cables (supervisory link and RS-232 to the PC).
7. When the test is completed, restore the original communication settings in the H201Ti as noted in the step 2 above.

8.2.6 Conclusion

This completes the incoming verification of the Hydran 201Ci-1.

1. Disconnect the H201Ti from the power outlet.
2. Disconnect the H201Ci-1 from the power outlet.
3. Remove all supply cables.
4. Remove all communication cables.
5. Store the H201Ti and the H201Ci-1 in their respective boxes, ready for installation.

6. If the H201Ti is not installed immediately, refer to Section 6.1.4 on page 6-5.
7. If the H201Ci-1 is not installed immediately, refer to Section 8.1.3 on page 8-2.

8.3 INSTALLATION

This Section explains how to install the Hydran 201Ci-1 Controller.

WARNING

Read all the warnings and recommendations in Section 5.1 on page 5-1 before proceeding with the installation.

Note: It is strongly recommended that the operation of all H201Ti's and H201Ci Controllers be verified before installation of the equipment in the field. Verification also allows the user to become familiar with the Hydran 201R Model i.

WARNING

All procedures in this manual must be strictly adhered to. Any deviation from these could cause irreversible damages to the transformer being monitored and/or the Hydran 201R Model i, and could lead to property damage, personal injury and/or death. Installation and maintenance of the Hydran 201R Model i must be carried out by qualified personnel only.

The H201Ci-1 is equipped with a Type NEMA 4X enclosure and internal heating; it can thus be installed outdoor.

8.3.1 Verifying the ac Power Supply Voltage and the Serial Numbers

Ensure steps 3 and 4 on page 8-2 have been performed.

8.3.2 Installing the Enclosure

Prepare the installation location of the Hydran 201Ci-1. Read the recommendations in Section 5.2.3 on page 5-12.

The H201Ci-1 must be mounted on a vibration-free structure. If vibrations are present, use vibration-absorbing rubber pads (Figure 1-5 on page 1-9), which can be purchased from General Electric Canada.

8.3.3 Installing the Cable Conduits

Note the following considerations prior to installing:

- All cables connected to the Hydran 201Ci-1 must be run through steel conduits. Otherwise, armored cables can be used.
- Flexible rather than rigid conduits should be used near the H201Ci-1 to ease installation and servicing.
- Conduits, or cable armors, should be made of steel to shield against magnetic fields.

The procedure is as follows:

1. Remove the rubber plugs from the required openings of the H201Ci-1 enclosure.
2. For each cable being used, install a standard watertight conduit fitting (not supplied). Up to six conduits may be installed (supervisory link, ac power supply, alarms and analog outputs).
3. Mount a conduit to each fitting.
4. Ground the conduits and/or cable shields at some point. Follow the company regulations meticulously.

8.3.4 Installing the Supervisory Link Cable

Note: The supervisory link cable has already been run into a conduit up to the Hydran 201Ci-1 if the installation of the Hydran 201Ti is completed (see Section 6.3.9 on page 6-26).

1. If required, trim the excess length from the end of the supervisory link cable from the H201Ti.

Note: The total maximum length of the supervisory link cable connected to a H201Ci-1 is 1,200 m (4,000 ft).

2. Ensure the six wires have been labelled (for identification purposes) at both ends.
3. Connect the cable wires and shield to the H201Ci-1's termination board. For wiring details, see Table D-11 on page D-8.

Note: The shield is grounded through a capacitor at the H201Ti end to protect against radiofrequency interference. Shields must also be directly grounded at the H201Ci-1's termination board.

WARNING

The H201Ci-1's operation may be affected if wires are not connected correctly. Be careful when installing and inserting each wire. Be sure to insert all strands in the terminal; strands that touch two terminals cause problems. Strip each wire to a maximum of 8 mm before installing it. Do not leave trims of metallic strands inside the H201Ci-1's enclosure.

8.3.5 Installing the Analog Output Cable (Facultative)

Perform this procedure only if the Hydran 201Ci-1's isolated, analog 4–20 mA output is used.

1. Run an instrumentation-grade cable (twisted pairs with individual and overall shields) through a conduit up to the H201Ci-1, or use an armored cable.

Note: The shield must be grounded at one end only.

2. Connect the cable to the main terminal block. For wiring details, see Table D-11 on page D-8.
3. Connect the cable to the SCADA system.

8.3.6 Installing the Alarms Cable (Facultative)

Perform this procedure only if the Hydran 201Ci-1's alarms are used.

1. Run the alarms cable through a conduit up to the SCADA system.
2. Connect the cable to the alarm contacts (terminals 7 to 15) of the main terminal block. For wiring details, see Table D-11 on page D-8.

Note: Do not switch heavy loads. See the relay ratings in Table D-11 on page D-8.

3. Connect the cable to the SCADA system.

8.3.7 Installing the ac Power Supply Cable

1. Run the three-wire ac power supply cable through a conduit up to the Hydran 201Ci-1.
2. Connect the cable to terminals 1 and 2 of the main terminal block, and connect the E/G wire to the enclosure chassis. For wiring details, see Table D-11 on page D-8.
3. Connect the other end of the cable to the power source.

WARNING

ELECTRICAL SHOCK HAZARD. Turn off the electric power at the fuse box or service panel before making any electrical connections, and ensure a proper ground connection is made before connecting line voltage. Failure to do so can result in property damage, personal injury and/or death.

4. If desired, connect the H201Ti's ac power supply cable to terminals 4 to 6 of the main terminal block.

WARNING

The earth/ground terminal (terminal 3) must be connected. Never perform high-voltage tests (mega-ohm measurements using a Megger* instrument) on cables connected to a Hydran 201Ti or a Hydran 201Ci Controller. Never apply high voltages to the components of a Hydran 201R Model *i*, as they are equipped with surge protection devices that could be damaged by Megger* tests.

8.3.8 Verifying the Operation

Proceed as described in Section 8.2.1 on page 8-3 and Section 8.2.2 on page 8-3.

8.3.9 Verifying the Analog Outputs

Perform this procedure only if the Hydran 201Ci-1's analog outputs are used (connected to a SCADA system).

Proceed as described in Section 8.2.3 on page 8-4.

8.3.10 Verifying Alarm Indicators and Alarm Relays

Proceed as described in Section 8.2.4 on page 8-6.

8.3.11 Verifying the Supervisory Link Communications

Verify communications between the Hydran 201*Ci*-1 and the Hydran 201*Ti* using a host computer running the Hydran Host software.

Proceed as described in Section 8.2.5 on page 8-9.

8.3.12 Conclusion

The installation of the Hydran 201*Ci*-1 is now completed.

8.4 OTHER INSTALLATIONS

To install other components of the Hydran 201R Model *i*, please consult the following Sections:

- Local network: See Section 9.5 on page 9-8.
- Optional modem: See Section 9.6 on page 9-11.

PAGE LEFT INTENTIONALLY BLANK

Communications and Networking

There are many possible configurations of Hydran 201*Ti* Intelligent Transmitters:

- It can be used alone.
- It can be combined with a Hydran 201*Ci*-1 One-Channel Controller (see Section 3.2 on page 3-7) to form a Hydran 201*R* Model *i*.
- From one to four H201*Ti*'s can be combined with a Hydran 201*Ci*-C Communications Controller (see Section 3.1 on page 3-1) to form a Hydran 201*i* System.

The following Sections describe:

- Communications within a Hydran 201*R* Model *i* or a Hydran 201*i* System, using a supervisory link: See Section 9.1 on page 9-1
- Communications in a network, using an RS-485 local network link: See Section 9.2 on page 9-3
- Communications with a host computer, using an RS-232 or USB serial communication link: See Section 9.3 on page 9-5
- Communication protocol: See Section 9.4 on page 9-8
- Installation of a local network: See Section 9.5 on page 9-8
- Installation of an optional modem: See Section 9.6 on page 9-11

9.1 COMMUNICATIONS WITHIN A HYDRAN 201R MODEL *I* OR A HYDRAN 201*I* SYSTEM, USING A SUPERVISORY LINK

In a Hydran 201*R* Model *i* or a Hydran 201*i* System, each Hydran 201*Ti* is linked to its Hydran 201*Ci* Controller using a cable referred to as *supervisory link*.

Note the following points:

- The total length of all supervisory link cables connected to a single H201*Ci* must not exceed 1,200 m (4,000 ft).
- The supervisory link uses a four- or six-wire shielded cable:
 - One shielded pair for the supervisory link's 15-Vdc power supply (unregulated and impedance-protected).

- One shielded pair to transmit serial communications.
- *For the Hydran 201Ci-1 only*: One shielded pair for the TDM (time division multiplexing) signal transmitted by the H201Ti (see Section 9.1.1 on page 9-2).
- Each supervisory link is electrically isolated and protected (2,000-V RMS opto-couplers, gas arresters, capacitors and tranzorbs) to withstand at both ends (H201Ti and H201Ci) surges up to 2,000 V RMS as well as the large noise transients and ground potential differences typically found in electrical substations.
- Bidirectional data communication is transparently passed by the H201Ci between the supervisory link port, the RS-485 LAN connector and the RS-232 Computer Port or USB connector. The communication path is half-duplex (one direction at a time, from a single talker).

The supervisory link cable can be connected at the following locations:

- In the H201Ti: To the Supervisory Link and Analog Output Termination Board (item 9 in Figure 2-4 on page 2-8).
- In the H201Ci-C: To the terminals 21 to 24 of the Main Terminal Block (item 5 in Figure 3-2 on page 3-3).
- In the H201Ci-1: To the terminals 21 to 24 of the Main Terminal Block (item 6 in Figure 3-6 on page 3-11).

9.1.1 TDM Pulse

The TDM pulse is used *only* with the Hydran 201Ci-1 Controller to transfer two pieces of information from the Hydran 201Ti to the H201Ci-1 itself:

- *Actual dissolved gas level*: This analog signal varies from 0 to 100 % (0 to 2,000 ppm) with a resolution of 1 part in 4,000.
- *Alarm relays status*: This digital information has four possible values, namely Normal, High, High-High and Fail.

The relationship between the alarm relay states, and the status of the H201Ti, of the TDM signal and of the H201Ci-1 is shown in Table 9-1 on page 9-3.

Table 9-1 - Alarm Relay States, and Status of the H201Ti, TDM Signal and H201Ci-1

Alarm ^a	Hydran 201Ti ^a				Sup. Link ^a	TDM ^a Signal	Hydran 201Ci-1 ^a				
	ac Power	Relays					ac Power	Relays			ppm Display
		Fail ^b	H	HH				Fail ^b	H	HH	
None	OK	On	Off	Off	OK	Normal	OK	On	Off	Off	On
H	OK	On	On	Off	OK	H	OK	On	On	Off	On
HH	OK	On	—	On	OK	HH	OK	On	On	On	On
Fail	OK	Off	—	—	OK	Fail	OK	Off	Off	Off	Off
—	—	—	—	—	Broken	Fail	OK	Off	Off	Off	Off
—	—	—	—	—	—	—	Out	Off	Off	Off	Off
—	Out	Off	Off	Off	—	—	—	Off	Off	Off	Off

a. — = Without consequence; H = High alarm; HH = High-High alarm; Sup. = Supervisory

b. On = Normal (no alarm); Off = Alarm

9.2 COMMUNICATIONS IN A NETWORK, USING AN RS-485 LOCAL NETWORK LINK

Up to 128 Hydran 201Ti Intelligent Transmitters can be connected in a single network to be monitored and controlled by computer. Once the H201Ti's are connected to a Hydran 201Ci-C or Hydran 201Ci-1 Controller via an isolated supervisory link, each Hydran 201Ci Controller is linked to the next H201Ci in a daisy-chain configuration via an isolated RS-485 LAN. An example of local network is shown in Figure 9-1 on page 9-4.

Any H201Ci in the network can then be linked to the host computer (see Section 9.3 on page 9-5). Each H201Ti can communicate with the host computer because each H201Ti is identified by a specific address (a number from 1 to 254) set by the user.

Note the following points:

- The total length of all RS-485 link cables in a single network must not exceed 1,200 m (4,000 ft). This corresponds to an average length of 40 m (120 ft) for a local network containing 32 H201Ci's.
- The RS-485 LAN uses an isolated, three-wire, shielded cable which is protected to withstand the large noise transients typically found in electrical substations.

- The H201Ci's manage all communications automatically (transmission and reception). Data transmission is half-duplex (one direction at a time, from a single talker).
- Ideally, the H201Ci's should be located in a limited zone of an electrical substation, for example the control room.

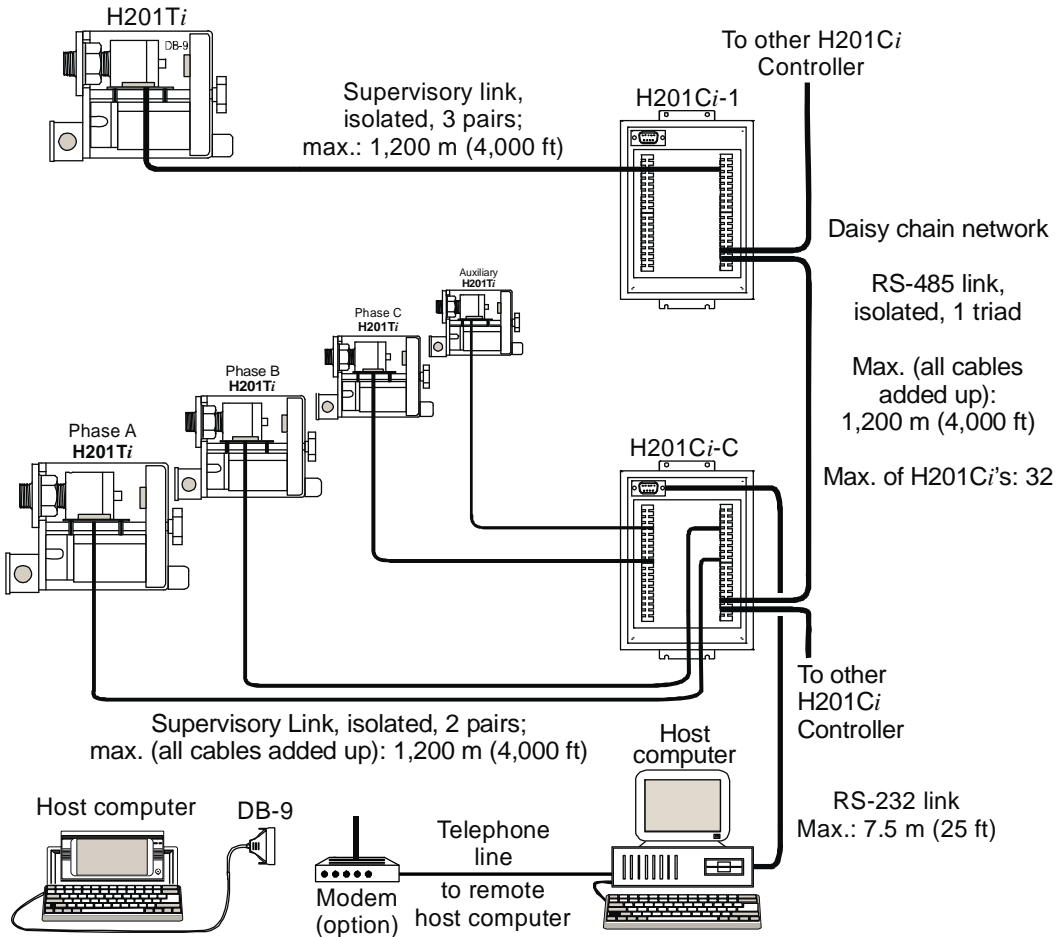

Figure 9-1 - Example of Local Network

The RS-485 local network link cable can be connected at the following locations:

- In the H201Ci-C: To the terminals 21 to 24 of the Main Terminal Block (item 5 in Figure 3-2 on page 3-3).

- In the H201Ci-1: To the terminals 21 to 24 of the Main Terminal Block (item 6 in Figure 3-6 on page 3-11).

The installation of an RS-485 local network link cable is described in Section 9.5.1 on page 9-9.

9.3 COMMUNICATIONS WITH A HOST COMPUTER, USING AN RS-232 SERIAL COMMUNICATION LINK

A Hydran 201Ti, a Hydran 201R Model *i*, a Hydran 201*i* System or a local network can be connected, either locally or remotely (through a modem), to a host computer via an RS-232 serial communication link. Figure 9-2 on page 9-5 illustrates the various ways to connect a host computer to a Hydran 201R Model *i*.

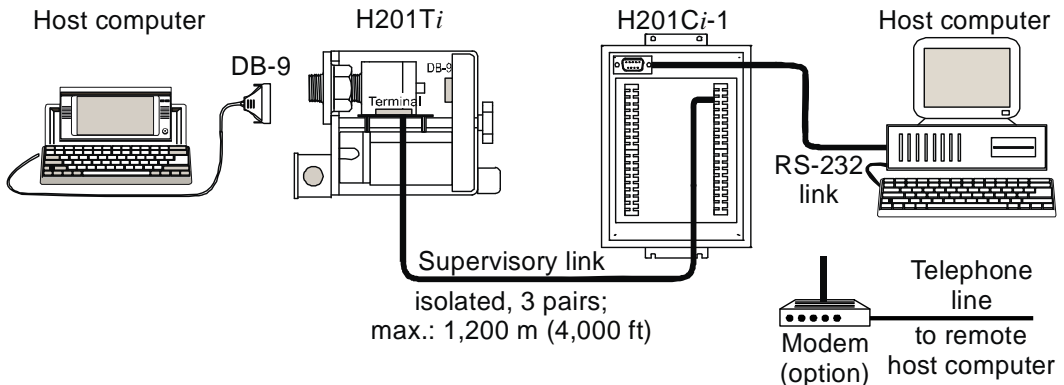

Figure 9-2 - Host Computer Connection Modes in a Hydran 201R Model *i*

The computer (or modem) can be attached to *any* Hydran 201Ci Controller on a local network. General Electric Canada's Hydran Host software is the easiest way to communicate directly with the H201Ci('s) or the network.

Note: A remote host computer can be used to supervise more than one local network of Hydran 201*i* Systems.

The RS-232 serial communication link cable can be connected at the following locations:

- In the H201Ti: To the DB-9 Male RS-232 Connector (item 5 in Figure 2-2 on page 2-5) on the back of the CPU module.

- In the H201Ci-C: To the DB-9 Male RS-232 Computer Port Connector J10 (item 7 in Figure 3-3 on page 3-5) on the circuit board.
- In the H201Ci-1: To the DB-9 Male RS-232 Computer Port Connector J10 (item 7 in Figure 3-7 on page 3-12).

The installation of an RS-232 serial communication link cable is described in Section 9.5.2 on page 9-10.

9.3.1 Local Communications

One or more Hydran 201R Model *i*'s and/or Hydran 201*i* Systems are connected to a host computer using an RS-232 serial communication link (DB-9 connector). This connection can be done as follows (see Figure 9-2 on page 9-5):

- By connecting the host computer to the DB-9 connector of a Hydran 201Ti. In this case, the communication can only be established with this particular H201Ti.
- By connecting the host computer to the DB-9 or USB connector of a Hydran 201Ci Controller. This connection gives access to all H201Ti's linked to this H201Ci and also, if present, to all H201Ti's of all H201Ci's in this local network.

The maximum distance for an RS-232 local link is 7.5 m (25 ft).

9.3.2 Remote Communications (via Modem)

One or more Hydran 201R Model *i*'s and/or Hydran 201*i* Systems are linked to a host computer by connecting a modem to a Hydran 201Ci Controller's DB-9 connector and a telephone system (private or public); see Figure 9-2 on page 9-5.

A Hayes-compatible modem can be pre-installed and pre-set at the factory in a H201Ci. For details on settings, refer to the modem procedure located in the **English/Procedures** folder of the Hydran 201*i* System installation CD. A typical communication configuration with a modem is shown in Figure 9-3 on page 9-7.

WARNING

The modems supplied by General Electric Canada should be connected to an analog line only. Using a non-analog line (for example, digital, PBX, Multi-line) will damage the modem.

Communications With a Host Computer, Using an RS-232 Serial Communication

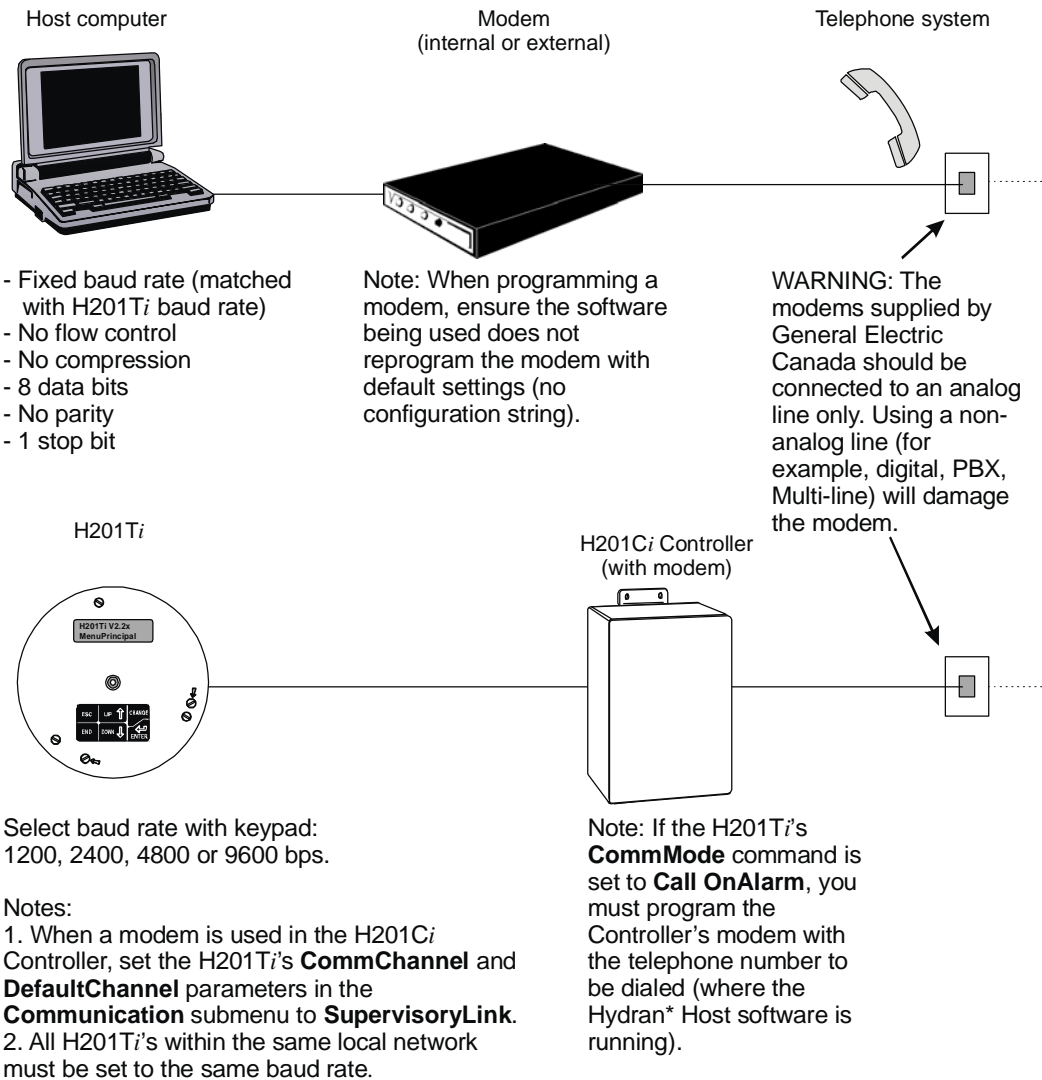

Figure 9-3 - Typical Communication Configuration With a Modem

If desired, the user can install his own modem, although a few settings must be expected to make it functional.

When using a modem, each Hydran 201Ti can be set to either one of the two following modes (in the **Communication** submenu; see Section 4.5.6 on page 4-21):

- **Call OnAlarm:** In this mode, the H201Ti communicates with the Hydran Host software through a telephone line each time a gas or fail alarm condition is detected (to select this mode, see Section 9.6.3 on page 9-13).
- **AnswerOnly:** In this mode, the H201Ti remains silent until a host computer running the Hydran Host software communicates with it.

In the **Call OnAlarm** mode, the following actions are performed when an alarm is triggered:

- The H201Ti sends the *ATDS0* command through the selected communication channel (RS-232 or supervisory link; see the **CommChannel** and **DefaultChannel** parameters in the **Communication** submenu).
- The Hayes-compatible modem receiving this command dials the telephone number previously stored in its register 0; this number is redialed until the connection with the host computer's modem is established. Then, no other message is sent; the host computer has the responsibility to communicate with the H201Ti in alarm.
- The Hydran Host software answers and receives the alarm message.
- The Hydran Host software displays the alarm states and updates its data bank.
- The user must acknowledge the alarm in the Hydran Host software and take the appropriate measures.

Note: Acknowledging the alarm in the Hydran Host software does not turn off the illuminated push-button of the Hydran 201Ci-1 Controller.

9.4 COMMUNICATION PROTOCOL

For serial communications, General Electric Canada uses its own protocol. Data is transmitted in ASCII codes; data clusters being transmitted are verified and, if necessary, transmitted again.

9.5 LOCAL NETWORK INSTALLATION

Read first the explanations in Section 5.2.4 on page 5-13.

9.5.1 Installing an RS-485 Local Network Link Between Hydran 201Ci Controllers

A local network is a chain of Hydran 201i Systems and/or Hydran 201R Model *i*'s in which the Hydran 201Ci Controllers are connected together using an RS-485 link. If the installation includes only one Hydran 201i System or Hydran 201R Model *i*, go to Section 9.5.2 on page 9-10.

Proceed as follows:

1. Run an RS-485 cable from one H201Ci to the next in a conduit to form a chain. Use instrumentation-grade cables (twisted triad with overall shield); otherwise use armored cables.

Note: The total maximum length for all RS-485 link cables in a local network is 1,200 m (4,000 ft).

WARNING The shield of each cable section must be grounded at one end only.

2. Connect the RS-485 cables into the main terminal block. For wiring details, see Appendix D.

Note: No wires are criss-crossed in an RS-485 link; pin 1 is always connected to pin 1, pin 2 to pin 2, pin 3 to pin 3. Except for the two H201Ci's located at each end of a local network, two RS-485 link cables are attached to each H201Ci using the Main Terminal Block. Powering down one H201Ci does not affect the local network nor the other H201Ci's.

WARNING The shield of each cable section must be grounded at one end only. Routing and shielding of the RS-485 cable is particularly important because all H201Ci's belonging to a network share a common reference with this link.

WARNING The operation of the complete H201Ci network may be affected if wires are not connected correctly. Be careful when installing and inserting each wire. Be sure to insert all strands in the terminal; strands that touch two terminals cause problems. Do not leave trims of metallic strands inside the H201Ci's enclosure.

9.5.2 Connecting a Host Computer to a Hydran 201Ci Controller in a Local Network, Using an RS-232 Cable

The supplied RS-232 cable (1.8 m [6 ft]) can be connected to any H201Ci in a local network to allow a host computer to communicate with all H201Ci's and Hydran 201Ti's in the network.

The RS-232 cable can be used as is; in the case of a permanent installation, you can also use a commercial null-modem cable (Rx and Tx wires are crossed) with female DB-9 connectors at both ends. Cut and splice the cable in order to be able to run it into the conduit fitting. These cables are available in lengths up to 7.7 m (25 ft).

WARNING The length of an RS-232 communication cable must not exceed 7.7 m (25 ft).

You can also make your own null-modem cable by using the same type of cable as for the RS-485 link. Wire the female DB-9 connector as shown in Table 9-2 on page 9-10.

Table 9-2 - Wiring for Serial Cables

From the Hydran 201Ci Controller	To the Host Computer
Female DB-9 connector, pin 2	Female DB-9 connector, pin 3
Female DB-9 connector, pin 3	Female DB-9 connector, pin 2
Female DB-9 connector, pin 5	Female DB-9 connector, pin 5

WARNING The shield of each cable section must be grounded at one end only. Ensure the H201Ci and the host computer share a common earth ground. Otherwise, use short-haul (private line) modem to provide electrical isolation between them.

9.5.3 Verifying RS-232 and RS-485 Communications

Proceed as described in Section 7.2.3 on page 7-4.

9.6 OPTIONAL MODEM INSTALLATION

Remote communications with a Hydran 201*i* System or a Hydran 201R Model *i* can be established using a telephone system (private or public). This Section pertains to Hydran 201*Ci* Controllers equipped with an internal modem (optional, available from General Electric Canada).

WARNING

The modems supplied by General Electric Canada should be connected to an analog line only. Using a non-analog line (for example, digital, PBX, Multi-line) will damage the modem.

9.6.1 Connecting a Telephone Line

1. Run a telephone line cable through a conduit up to the Hydran 201*Ci* Controller equipped with a modem.
2. Connect the telephone line cable.

WARNING

When using a modem, a solid-state station protector (model Circa 1360B or equivalent) must be installed on the modem telephone line within 20 meters of the Hydran 201*Ci* Controller to ensure proper operation of the modem during network disturbances.

9.6.2 Verifying Communications Between the Two Modems

Once the modems are set up, proceed as follows to verify modem communications:

1. Power up the host computer.
2. Start the Hydran Host software.
3. If not already done, use this software to prepare the communication with the Hydran 201*Ti*'s by entering the definition of all H201*Ti*'s in the network according to the identification numbers previously assigned. For details, see the *Hydran Host Software Manual*.
4. Enter the model name and configuration string of the modem in the **Host Config** window of the Hydran Host software (see the *Hydran Host Software Manual*).

5. In the Hydran Host software, enter the telephone number and the communication speed of the H201Ci's modem in the **Power Stations Set-Up** window (see the *Hydran Host Software Manual*).

Note: The communication speed assigned to the power station in the Hydran Host software must be the same as the one set in all H201Ti's in the local network.

6. If the H201Ti's **Call OnAlarm** command is used, program the H201Ci's modem with the telephone number of the host computer's modem.
7. If not already done, set the communication speed of the H201Ti's. To do so, access the submenu **Communication** of each H201Ti and set the parameter **BaudRate** to the same speed as the one indicated in the **Power Stations Set-Up** window for this power station.
8. If the H201Ti communication speed is set for the first time, you must initialize the H201Ci's modem with this communication speed. To do so, access the submenu **Communication** of one of the H201Ti's connected to this H201Ci, select the **Force HostCall** command and press **ENTER**.

Note: This task can be performed even if the H201Ci's modem is not connected to a telephone line and even if this modem is not yet programmed with a telephone number.

9. If the H201Ti's **Call OnAlarm** command is not used (the H201Ci's modem is not programmed with the telephone number of the host computer's modem), you must use the Hydran Host software to trigger the communications between the two modems. In the Hydran Host software, start the **Hydran Host** module, click **Remote** and then **Call Now** (see the *Hydran Host Software Manual*).
10. Verify the status of communications with the H201Ti's in the **Network Survey** window of the Hydran Host software (see the *Hydran Host Software Manual*).

Note: The Hydran Host software, the communication software and the modem must use the same communication port (COM1 or COM2).

9.6.3 Configuring the Call OnAlarm Mode

Prior to use the **Call OnAlarm** mode, make sure of the following:

- The installation of the Hydran 201*i* System is completed.
- The network configuration is defined in the Hydran Host software (see the *Hydran Host Software Manual*).
- The Hydran 201*Ci* Controller's modem is programmed with the telephone number of the host computer's modem.

To use the **Call OnAlarm** mode, proceed as follows:

1. In the Hydran Host software, start the **Hydran Host** module.
2. Click **Remote**.
3. In the **Remote Access** window, select the desired power station.
4. Click **Put on Watch**.

The following actions are then performed:

1. The Hydran Host software initializes the host computer's modem.
2. This modem telephones to the H201*Ci*'s modem.
3. The Hydran Host software sets to **Call OnAlarm** the **CommMode** parameter of all Hydran 201*Ti*'s in the Hydran 201*i* System or in the local network.
4. The Hydran Host software hangs up.

PAGE LEFT INTENTIONALLY BLANK

This Chapter explains in detail the sophisticated alarm features of the Hydran 201i System from an operator's point of view.

Note: The complete list of alarm messages and each corresponding troubleshooting procedure are given in Section 12.1 on page 12-1.

WARNING

Wiring the alarm contacts (see Section 10.2.1 on page 10-4) to safety tripping devices of the equipment monitored by the Hydran 201i System is not recommended because this system is an early warning device of incipient faults. Information obtained using the Hydran 201i System should always be used in conjunction with other available information to decide if the monitored equipment should be removed from service.

WARNING

This Chapter contains examples of how to set the gas alarm parameters of the Hydran 201i System. The values used are fictitious and do not correspond to any standard. General Electric Canada does not suggest nor recommend specific alarm set points. It is solely the responsibility of the user to determine the appropriate settings.

There are two methods to set the value of the alarm parameters:

- Using the Hydran Host software (see the *Hydran Host Software Manual*).
- Directly, using the Hydran 201Ti's keypad and display (they are explained in detail in Chapter 4).

For more information on the interpretation of gases in oil, refer to the following guides:

- IEEE Standard C57.104-1991, "IEEE Guide for the Interpretation of Gases Generated in Oil-Immersed Transformers"
- IEC 60599-1999, "Mineral Oil-Impregnated Electrical Equipment in Service – Guide to the Interpretation of Dissolved and Free Gases Analysis"

10.1 ALARM LEVELS

The Hydran 201*i* System is a microprocessor-based family of instruments with sophisticated alarm features. It is equipped with three alarm levels:

- *Gas High alarm* (Hydran 201Ti's Alarm 1): This alarm is set at a lower gas level than the High-High alarm. It is a caution sign and should initiate closer monitoring of the equipment.
- *Gas High-High alarm* (H201Ti's Alarm 2): This alarm is set at a higher level than the High alarm. It is a warning sign and should trigger immediate operator action according to standard utility procedures.
- *Fail alarm of the Hydran 201i System*: This alarm includes all alarms other than the High and High-High alarms. The fail alarm warns the operator that the Hydran 201*i* System is not functioning properly. A fail alarm must therefore be verified and solved rapidly because it indicates that the *monitoring* system (the Hydran 201*i* System) of the transformer is faulty.

Note: A fail alarm does not concern the transformer.

The High and High-High alarms provide an *early warning of incipient faults* in transformers or any other oil-filled electrical equipment.

10.1.1 Alarm Conditions

An alarm is triggered when an *alarm condition* is detected. Each alarm has its own set of alarm conditions.

Gas High and High-High alarms are triggered by one or several of the following conditions:

- The *level of gases in oil* exceeds the user-defined alarm set point (250 ppm, for example). The gas level is a composite value of the following gases: Hydrogen (H₂), carbon monoxide (CO), acetylene (C₂H₂) and ethylene (C₂H₄).
- The *hourly trend* (short term) of the gas level exceeds the user-defined alarm set point (10 ppm per 24 hours, for example). The hourly trend represents the level variation of gases in the oil during a period of time measured in hours. The hourly trend is updated every five seconds.
- The *daily trend* (long term) of the gas level exceeds the user-defined alarm set point (25 ppm per 30 days, for example). The daily trend represents the level variation of gases

in the oil during a period of time measured in days. The daily trend is updated every five minutes.

The complete list of fail alarm conditions is shown in Section 10.5.1 on page 10-14.

Table 10-1 on page 10-3 lists the alarm conditions monitored by the Hydran 201Ti.

Table 10-1 - Alarm Conditions Monitored by the Hydran 201Ti

Source	Possible States			
Gas level	Low-Low	Low	High	High-High
Hourly trend				
Daily trend				
Sensor temperature			—	—
Battery voltage				
Sensor and connections	Cable ^a short	Replace sensor soon	Replace sensor now	Cable ^a open

a. Either one of the following cables (or connectors in the connection link): Sensor, sensor thermistor, or heating plate thermistor.

10.1.2 Purpose of Hourly and Daily Trends

Detection of hourly and daily trend alarm conditions is a unique feature of the Hydran 201i System that provides early warning of slowly increasing gas level. For example, let us consider a transformer with a 50-ppm gas level and a typical gas High alarm set point of 150 ppm.

- If no trend alarm is used and if the gas level reading starts increasing at the rate of 50 ppm per month, it takes two months before the gas High alarm condition is detected and the investigation of the possible causes of the increase begins (unless the gas reading was already closely monitored).
- If the *daily trend* High alarm is used and its alarm set point is adjusted to 25 ppm, its period to 30 days and its alarm delay to 33 % of the period (10 days), the alarm would occur approximately 23 days after the beginning of the gas level increase. Investigation of the possible causes could thus start five weeks earlier. For details on trend computations, see Section 10.4.3 on page 10-12.

10.2 ALARM RELAYS

The Hydran 201Ti and the Hydran 201Ci-1 both have three alarm relays, in other words one relay per alarm level:

- One gas High alarm relay
- One gas High-High alarm relay
- One fail alarm relay, referred to as *System* in the H201Ti's menus

Note: The Hydran 201Ci-C does not have alarm relays. The H201Ci-1 alarm relays are more accessible than the H201Ti's relays. Generally, the H201Ci-1 alarm relays are the ones connected to an alarm panel or SCADA system.

10.2.1 Alarm Contacts

Each relay has:

- A normally open (NO) contact
- A normally closed (NC) contact
- A common contact (Type C)

The physical form of these contacts is as follows:

- Hydran 201Ti: See the Alarm Contacts 9-Terminal Block (item 12 in Figure 2-5 on page 2-9).
- Hydran 201Ci-1: See the terminals 7 to 15 of the Main Terminal Block (item 6 in Figure 3-6 on page 3-11).
- Hydran 201Ci-C: Does not have alarm relays and thus no alarm contacts.

10.2.2 Status of Alarm Relays

The gas High and High-High alarm relays can only be in two states:

- On (coil energized, alarm state LED's turned on)
- Off (coil de-energized, alarm state LED's off)

Note: The relays of the Hydran 201Ci Controller always adopt the state of the Hydran 201Ti's corresponding relay (except if the supervisory link is broken, in which case

the H201Ci triggers a fail alarm, regardless of the H201Ti's fail alarm relay). As far as the fail alarm relay, the coil is energized in normal operation (no alarm).

Table 9-1 on page 9-3 lists the possible states of all relays. The state of each relay can be determined as follows:

- H201Ti:
 - By displaying **RelayH State**, **RelayHH State** and **SysOk State** in the **Relays/Analog** submenu.
 - By looking at the LED's on the right side of the I/O module (see Figure 2-7 on page 2-12).
 - By verifying the state of the alarm contacts on the Alarm Contacts 9-Terminal Block (item 12 in Figure 2-5 on page 2-9).
- H201Ci-1:
 - By looking at the LED's on the circuit board (see items 13 to 18 in Figure 3-7 on page 3-12).
 - By verifying the status of the alarm contacts on the terminals 7 to 15 of the Main Terminal Block (item 6 in Figure 3-6 on page 3-11).
 - By looking at the illuminated **1** (High alarm) and **2** (High-High alarm) push-buttons on the enclosure door.
- H201Ci-C: No alarms.

Table 10-2 on page 10-5 lists the possible states of the alarm contacts.

Table 10-2 - Possible States of the Alarm Contacts

	Off	On
NO contact	Contact open	Contact closed
NC contact	Contact closed	Contact open

10.2.3 Operation Modes of Alarm Relays

The mode of each alarm relay is set using the corresponding **RelayMode** parameter in the Hydran 201Ti's **Relays/Analog** submenu (or using the Hydran Host software). There are four operation modes:

- **Normal**: See Section 10.2.3.1 on page 10-6.
- **Latch**: See Section 10.2.3.2 on page 10-6.

- **Force OFF:** See Section 10.2.3.3 on page 10-7.
- **Force ON:** See Section 10.2.3.4 on page 10-7.

The H201Ti's three relays are independent. A relay can therefore be set to any operation mode regardless of the mode of the two other relays.

10.2.3.1 Normal Mode

In this mode, the relay status changes if an alarm condition is detected during a period of time exceeding the corresponding alarm delay; the relay returns to its former status when the alarm condition disappears during a period of time exceeding the same alarm delay. The **Normal** mode is the default setting.

In the **Normal** and **Latch** modes:

- The High and High-High alarm relays are *energized* when an alarm condition is detected.
- The fail alarm relay, however, is *de-energized* when an alarm condition is detected, to permit to detect a power failure (the relay's power being immediately off). This feature of the Hydran 201i System strengthens the security of the alarm system. The fail alarm relay is thus *energized* (NO contacts closed and NC contacts open) if no alarm condition is detected.

10.2.3.2 Latch Mode

In this mode, the relay status changes if an alarm condition is detected during a period of time exceeding the corresponding alarm delay; the relay returns to its former status when the alarm condition disappears during a period of time exceeding the same alarm delay *and* when the alarm is acknowledged by the user (using the Hydran 201Ti's keypad or the Hydran Host software).

Note: Only pushing the Hydran 201Ci-1's push-buttons is not enough to acknowledge an alarm.

Read also the points in the **Normal** mode (Section 10.2.3.1 on page 10-6).

10.2.3.3 Force OFF

In this mode, the relay does not respond to changes in alarm conditions; the relay's power always remains off. This mode is used mainly to test the alarm relays or disable an alarm circuit.

10.2.3.4 Force ON

In this mode, the relay does not respond to changes in alarm conditions; the relay's power always remains on. This mode is used mainly to test the alarm relays or disable an alarm circuit.

10.3 ALARM INTERFACE

The alarm interface between the Hydran 201*i* System and the user can take different forms. When an alarm is triggered, the following actions are generated:

1. An alarm message flashes on the Hydran 201Ti's display. For example: **Gas H;250 ppm** (the gas level exceeds the gas High alarm set point, which is currently set to 250 ppm). For the complete list of alarm messages, see Section 12.1 on page 12-1; for details on the display of alarm messages, see Section 4.2.1 on page 4-3.
2. The status of the corresponding alarm relay changes. The classic interface method consists in linking the relays' alarm contacts of the Hydran 201Ci Controller (or H201Ti) to an alarm panel (or any other SCADA system) located in such a way that an alarm being triggered would immediately warn the operator. For details, see Section 11.1.2 on page 11-2.
3. An alarm signal is transmitted (through the supervisory link) to the H201Ci and from the latter to the host computer. The Hydran Host software (if running) displays an alarm window. This way, the state of the alarms can be continuously monitored (locally or remotely) or verified periodically.
4. A call can be made to a host computer via modem (see the **CommMode** parameter in the H201Ti's **Communication** submenu; Section 4.5.6.2 on page 4-22).
5. The two illuminated push-buttons (alarm indicators) mounted on the door of the Hydran 201Ci-1 (the Hydran 201Ci-C is not equipped with push-buttons) indicate the

status of the gas alarms. Each push-button turns on when the corresponding alarm is triggered. The push-button’s alarm indicator is latched; in other words, it remains on even if the alarm condition has disappeared and even if the alarm is acknowledged (using the H201Ti’s keypad or the Hydran Host software). To turn it off, you must press the corresponding push-button; an alarm indicator can only be turned off if the alarm condition has disappeared during a period of time exceeding the corresponding alarm delay (one of the alarm parameters). Table 10-3 on page 10-8 lists the possible states of the Hydran 201Ci-1’s display and alarm indicators.

Table 10-3 - Possible States of the Hydran 201Ci-1’s Display and Alarm Indicators

State	Display	High Indicator	High-High Indicator
Normal	Normal	Off	Off
High alarm		On (Latch)	
High-High alarm		On	On (Latch)
Fail alarm	Off	Unchanged	Unchanged
Power failure		Off	Off

- During a fail alarm, the Hydran 201Ci-1’s display is blank (see Table 10-3 on page 10-8), and the analog outputs of the H201Ti and the H201Ci-1 drop to 4.00 ± 0.10 mA.
- A message is recorded in the H201Ti’s **History;Events** file. Alarm messages are thus stored in memory. The Events file can contain up to 500 messages. Each message comes with a set of relevant parameters (gas level, trends, etc.) and is identified with the recording date and time. For details, see Section 4.5.1 on page 4-12.

10.4 GAS HIGH AND HIGH-HIGH ALARMS

Parameters pertaining to gas High and High-High alarms are set in the Hydran 201Ti’s **Gas** submenu. For explanations on each parameter, see Section 4.5.2 on page 4-16.

Set points for High alarms should be adjusted at values that indicate that the transformer (or other equipment) requires *closer monitoring*. Set points for High-High alarms should be adjusted at values considered as critical by the user, meaning that the transformer requires *immediate action*; in general, this alarm implies an evaluation of the equipment and its possible removal from service.

10.4.1 Alarm Parameters Setting

10.4.1.1 Gas Level

The gas level alarm uses the following parameters:

- **GasAlr H** and **GasAlr HH**: Gas High and High-High alarm set points.
- **GasAlr Delay**: The gas alarms delay determines the period of time during which the gas level must exceed the gas High and High-High alarm set points in order to trigger the alarm. Accordingly, the gas level must get below the alarm set point for the same amount of time in order to cancel the alarm.

Before setting these alarm set points, the readings of the Hydran 201i System should be monitored over a minimum period of two weeks. A simple method to monitor this value is to consult the Hydran 201Ti's historic data files using its keypad (see Section 4.5.1 on page 4-12) or a host computer running the Hydran Host software.

Follow these rules:

- Adjust the High set point above the highest reading that was obtained.
- Adjust it low enough to detect the earliest sign of an abnormal increase of gas.
- But set it at a value high enough to minimize unnecessary alarms.

Table 10-4 on page 10-10 contains *suggested* guidelines for setting the *gas level High alarm condition*, according to the maximum reading obtained during the monitoring period.

WARNING

This Chapter contains *examples* of how to set the gas alarm parameters of the Hydran 201i System. The values used are fictitious and do not correspond to any standard. General Electric Canada does not suggest nor recommend specific alarm set points. It is solely the responsibility of the user to determine the appropriate settings.

Table 10-4 - Suggested Guidelines for Setting the Gas Level High Alarm Condition

Hydran 201Ti Maximum Reading Obtained During the Monitoring Period	Minimum Suggested Alarm Set Point to Reduce the Likelihood of Unnecessary Alarms
Below 70 ppm	100 ppm
From 70 to 400 ppm	1.5 times the highest H201Ti reading
Above 400 ppm	200 ppm above the highest H201Ti reading

10.4.1.2 Hourly Trend

The hourly trend alarm uses the following parameters:

- **HourTrAlr H** and **HourTrAlr HH**: Hourly trend High and High-High alarm set points.
- **HourTrAlr Delay**: The hourly trend alarm delay determines the period of time during which the hourly trend must exceed the corresponding High and High-High alarm set points in order to trigger the alarm. Accordingly, the hourly trend must get below the alarm set point for the same amount of time in order to cancel the alarm. This delay is set in percentage of the *period* of the hourly trend computation.
- **HourlyTr Period**: The period of time (in hours) during which the hourly trend is calculated. Increasing the period decreases the normal fluctuations of the readings, but increases the response time.

The readings of the Hydran 201i System should be monitored over a minimum period of two weeks before setting these parameters; follow the same rules as for the gas High alarm (see Section 10.4.1.1 on page 10-9).

10.4.1.3 Daily Trend

The daily trend alarm uses the following parameters:

- **DayTrAlr H** and **DayTrAlr HH**: Daily trend High and High-High alarm set points.
- **DayTrAlr Delay**: The daily trend alarm delay determines the period of time during which the daily trend must exceed the corresponding High and High-High alarm set points in order to trigger the alarm. Accordingly, the daily trend must get below the alarm set point for the same amount of time in order to cancel the alarm. This delay is set in percentage of the *period* of the daily trend computation.

- **DailyTr Period:** The period of time (in days) during which the daily trend is calculated. Increasing the period decreases the normal fluctuations of the readings, but increases the response time.

The readings of the Hydran 201i System should be monitored over a minimum period of two months before setting these parameters; follow the same rules as for the gas High alarm (see Section 10.4.1.1 on page 10-9).

10.4.2 Guidelines for Setting Trend Alarms

The hourly and daily trend High and High-High alarm settings cannot be described in terms of absolute criteria. They are related to the user's field experience and the utility's standard practice.

This Section provides a few guidelines to optimize both the hourly and daily trend alarms.

1. If a fast response to a sudden gas level increase is needed, it is best to rely on the gas level alarm rather than on trend alarms. Trend alarms are ideal when it comes to detect slow and steady changes from fluctuating readings, but are not as good to detect abrupt changes.
2. The transformer's (or other equipment) past history and the user's field experience are the most important criteria for alarm settings. If existing, records of previous dissolved gas analysis (DGA) for the equipment monitored should be used to help determine alarm settings in general and especially daily trend settings.
3. Trend alarm delays should be set according to each trend period. For example:
 - If the hourly trend period is set to four hours, the hourly trend reading may show quite large, but short, positive and negative peaks during a day. In this case, a hourly trend alarm delay of 50 to 75 % of the period could avoid unnecessary alarms.
 - However, if the hourly trend period is set to 48 hours, daily fluctuations would not affect the trend reading significantly. In this case, the alarm delay could be set to 10 to 20 % of the period.
4. The hourly trend period should be long enough to filter out reading fluctuations caused by short-term changes in ambient conditions and transformer operation. The factory default of 24 hours is a good starting value.

5. The longer the trend period, the higher the trend value in ppm is for a given steady increase in gas level reading. For example, a constant gas level increase of 10 ppm/24 hours results in a 10 ppm/period reading if the period is set to 24 hours, but in a 20 ppm/period reading if the period is set to 48 hours.
6. The longer the period, the smoother the trend readings are. However, it takes longer for the trend to stabilize (“taper off”) to its final value. In the preceding example, it would take two days to obtain the final value of 10 ppm/24 hours; in the second case, it would take four days to reach the final value of 20 ppm/48 hours (for details on computations, see Section 10.4.3 on page 10-12).

10.4.3 Hourly and Daily Trend Computations

A unique computation method is used for both the hourly and daily trends. In these computations, the gas level reading is processed through a first-order, digital, low-pass filter; the trend reading (slope) is then extracted using a first-order, digital, high-pass filter. The time constants for both filters are set to 33 % of the trend period for optimum results.

Table 10-5 on page 10-12 and Table 10-6 on page 10-12 show two examples of trend computations.

Example 1: The gas level starts to increase at a rate of 10 ppm/24 hours. The hourly trend period is set to 24 hours.

Table 10-5 - Evolution of the Hourly Trend

Initial	After 8 hours	After 24 hours	After 48 hours
0 ppm/24 h	+4 ppm/24 h	+9 ppm/24 h	+10 ppm/24 h

Example 2: The gas level starts to increase at a rate of 50 ppm/30 days. The daily trend period is set to 30 days.

Table 10-6 - Evolution of the Daily Trend

Initial	After 10 days	After 30 days	After 60 days
0 ppm/30 d	+20 ppm/30 d	+45 ppm/30 d	+50 ppm/30 d

Note the following points:

- If the Hydran 201Ti undergoes a power failure that lasts less than 1/6 of the trend period, the corresponding trend reading remains constant until the H201Ti is powered up again.
- If the power failure lasts more than 1/6 of the trend period, the corresponding trend reading is reset to zero.
- If the user changes the hourly or daily trend period, the corresponding trend reading is reset to 0.0 ppm/period.

10.4.4 High and High-High Alarms Triggering

If the High alarm relay is set to the **Normal** or **Latch** mode, the High alarm is triggered (the High alarm relay is energized) when one of the alarm conditions *exceeds* the corresponding High alarm set point during a period of time exceeding its alarm delay.

The same way, if the High-High alarm relay is set to the **Normal** or **Latch** mode, the High-High alarm is triggered (the High-High alarm relay is energized) when one of the alarm conditions *exceeds* the corresponding High-High alarm set-point during a period of time exceeding its alarm delay.

Each alarm (High and High-High) can be triggered by one or several of the following conditions (for details, see Section 10.1.1 on page 10-2):

- Gas level (**GasLevel** submenu)
- Hourly trend (**HourlyTrend** submenu)
- Daily trend (**DailyTrend** submenu)

Each alarm condition has an adjustable alarm delay that is common to all levels (High, High-High, Low and Low-Low) of this condition.

10.4.5 High and High-High Alarms Cancellation

Note: To be cancelled, an alarm condition must disappear during a period of time exceeding the corresponding alarm delay.

To cancel a High or High-High alarm, proceed as follows:

1. Find and solve the problem. Generally, the Hydran 201Ti's reading must be verified by sampling the transformer's oil and performing a dissolved gas analysis (DGA)

2. Acknowledge the alarm using the H201Ti's keypad or the Hydran Host software. For the procedure, see Section 4.2.1 on page 4-3, and the *Hydran Host Software Manual*. If the problem has been corrected since a period of time exceeding the corresponding alarm delay, the alarm message then disappears from the H201Ti's display; otherwise, it simply stops flashing and remains on the display.
3. Press the Hydran 201Ci-1's corresponding push-button.

10.5 FAIL ALARM

The fail alarm generally indicates to the user that there is a problem with the Hydran 201i System, not with the transformer. A fail alarm must therefore be verified and solved rapidly because it indicates that the *protection* system of the transformer is not functioning properly.

10.5.1 Fail Alarm Triggering

If the fail alarm relay is set to the **Normal** or **Latch** mode, the fail alarm is triggered (the fail alarm relay is de-energized) when one of the following alarm conditions occurs:

- Supervisory link broken between the Hydran 201Ti and the Hydran 201Ci Controller. This condition is the only one that affects *only* the fail alarm relay of the Hydran 201Ci-1. All other conditions affect the fail alarm relays of both the H201Ti and the H201Ci-1.
- ac power failure or partial failure (power voltage too low for the H201Ti to function properly).
- Unable to restart the microprocessor.
- H201Ti not initialized (no alarm message appears on the H201Ti's display for this condition). To cancel this alarm, enter the information requested on the H201Ti's display (for details, see Section 4.2.5 on page 4-6).
- More than 20 “watchdogs” occurred in 15 minutes (no alarm message appears on the H201Ti's display for this condition).
- Detection of a hardware malfunction during the autoverification phase of the initialization (no alarm message appears on the H201Ti's display for this condition).
- **Setup Lost** (for details, see Section 12.1.24 on page 12-13).
- One of the fault triggers conditions, listed in Table 10-1 on page 10-3 (for details, see Section 10.5.2 on page 10-15).

10.5.2 Fault Triggers

Fault triggers are fail alarm conditions that can produce two actions:

- Display of a message on the screen. The alarm message is displayed only if the corresponding alarm set point is adjusted to a value; if not, it is set to **OFF**. This setting is performed in the corresponding submenu.
- Trigger of the fail alarm relay. Whether the relay is triggered when an alarm condition is detected is determined in the **SysOK Relay;FaultTrig.** submenu.

*Note: The alarm set point adjustment has priority over the relay triggering. In other words, the relay is not triggered if the alarm set point is adjusted to **OFF**.*

Almost all these alarm conditions have an alarm set point and an alarm delay (both can be adjusted). The fail alarm, for these conditions, is therefore triggered the same way than the *gas* High and High-High alarms:

- Low and Low-Low alarms: The fail alarm is triggered when one of the alarm conditions is *below* the corresponding alarm set point during a period of time exceeding its alarm delay.
- High and High-High alarms: The fail alarm is triggered when one of the alarm conditions *exceeds* the corresponding alarm set point during a period of time exceeding its alarm delay.

10.5.2.1 Gas Fault Triggers

The conditions shown in Table 10-7 on page 10-16, although being Low and Low-Low gas alarms, are classified as fail alarms because they indicate a problem of gas detection rather than one of gas production in the transformer. A gas Low alarm, for example, is triggered if the valve on which is mounted the Hydran 201Ti is closed.

The parameters pertaining to these alarm conditions are set in the H201Ti's **Gas** and **SysOK Relay;FaultTrig.** submenus (for explanations, see Chapter 4).

Table 10-7 - Gas Fault Triggers

Description	Priority	Alarm Set Point	Fault Trigger	Alarm Message
Low-Low gas level	Average	GasAlr LL	Gas LL	
Low gas level		GasAlr L	Gas L	
Low-Low hourly trend		HourTrAlr LL	HourTrend LL	
Low hourly trend		HourTrAlr L	HourTrend L	
Low-Low daily trend		DayTrAlr LL	DayTrend LL	
Low Daily trend		DayTrAlr L	DayTrend L	

10.5.2.2 Sensor Temperature Fault Triggers

The parameters pertaining to these alarm conditions are presented in Table 10-8 on page 10-16 and set in the Hydran 201Ti’s **Temperature** and **SysOK Relay;FaultTrig.** submenus (for explanations, see Chapter 4).

Table 10-8 - Sensor Temperature Fault Triggers

Description	Priority	Alarm Set Point	Fault Trigger	Alarm Message
Low-Low sensor temperature	Average	STempAlr LL	SensTemp LL	
Low sensor temperature	Low	STempAlr L	SensTemp L	
High sensor temperature	Low	STempAlr H	SensTemp H	
High-High sensor temperature	Average	STempAlr HH	SensTemp HH	

For explanations on the heating system, see Section 2.6 on page 2-14.

10.5.2.3 Battery Voltage Fault Triggers

The parameters pertaining to these alarm conditions are presented in Table 10-9 on page 10-17 and set in the H201Ti’s **Service;Battery** and **SysOK Relay;FaultTrig.** submenus (for explanations, see Chapter 4).

Table 10-9 - Battery Voltage Fault Triggers

Description	Priority	Alarm Set Point	Fault Trigger	Alarm Message
Low-Low battery voltage	Average	Batt.Alr LL	Batt. LL	
Low battery voltage	Very low	Batt.Alr L	Batt. L	

For explanations on the battery, see Section 2.7 on page 2-15.

10.5.2.4 Sensor Operation and Connections Fault Triggers

A sensor test is automatically performed on the first and fifteenth days of each month at midnight, and relevant parameters are recorded in the **History;Service** file. The test can also be forced manually (**Service;ForceSensor Test** command), but the result is not recorded. In both cases, one of the alarm messages shown in Table 10-10 on page 10-17 is displayed if the sensor fails the test.

Table 10-10 - Sensor Operation and Connections Fault Triggers

Description	Priority	Alarm Set Point	Fault Trigger	Alarm Message
Replace sensor soon	Average	None	SensRep Soon	Replace SensSoon
Replace sensor now	Very high		SensRep Now	Replace SensNOW
Cable ^a short			CableShort	
Cable ^a open			CableOpen	

a. Either one of the following cables (or connectors in the connection link): Sensor, sensor thermistor or heating plate thermistor.

10.5.3 Fail Alarm Cancellation

Note: To be cancelled, an alarm condition must disappear during a period of time exceeding the corresponding alarm delay (if existing for this condition).

To cancel a fail alarm, proceed as follows:

1. Find and solve the problem (for help, see Section 10.5.2 on page 10-15).

2. Acknowledge the alarm using the Hydran 201Ti's keypad or the Hydran Host software. For the procedure, see Section 4.2.1 on page 4-3, and the *Hydran Host Software Manual*. If the problem has been corrected during a period of time exceeding the corresponding alarm delay, the alarm message then disappears from the H201Ti's display; otherwise, it simply stops flashing and remains on the display.

Operating the Hydran 201*i* System

WARNING

Read all the warnings and recommendations in Section 5.1 on page 5-1 before proceeding with the operation.

11.1 OPERATING METHODS

The Hydran 201*i* System can be operated using several methods. Each of these methods is explained in the following pages, from the simplest to the most powerful one:

- Periodic, visual monitoring: See Section 11.1.1 on page 11-1.
- Alarm monitoring: See Section 11.1.2 on page 11-2.
- Analog output monitoring: See Section 11.1.3 on page 11-3.
- Combined alarm and analog output monitoring: See Section 11.1.4 on page 11-4.
- Local monitoring with host computer: See Section 11.1.5 on page 11-4.
- Remote monitoring with host computer: See Section 11.1.6 on page 11-5.

11.1.1 Periodic, Visual Monitoring

Among the Hydran 201*i* System's operating methods, the *periodic, visual monitoring* is the simplest. If used, the following routine must be an integral part of the on-site, station inspection:

- Periodic, visual reading (once or twice a day) of the gas level reading on the display of the Hydran 201Ti's or the Hydran 201Ci-1. For details on the various methods of data reading, see Section 11.2 on page 11-5.
- On-site verification of alarms. For details on the alarms and relays operation, see Chapter 10.
- Manual logging of the above results.

Only basic training to the station's personnel is required to implant this operating method. When an alarm is detected, the operator must report the alarm and take the appropriate actions for this type of alarm (follow the regulations and practices of the company).

Note: With this method, the analog outputs and the alarm contacts are not connected to a SCADA system.

11.1.1.1 Method Drawbacks

The *periodic, visual monitoring* method has a deficient response time following the detection of an alarm; this response time cannot be inferior to the period of time between two inspections. The Hydran 201i System, however, has a response time measured in minutes.

11.1.2 Alarm Monitoring

The *alarm monitoring* method solves the disadvantages of the *periodic, visual monitoring* method as follows:

- Connecting the alarm contacts to an alarm panel (or any other SCADA system) located in the station's control room.
- Continuous alarm monitoring.
- Periodic, visual reading (weekly) of the gas level on the display of the Hydran 201Ti's or the Hydran 201Ci-1. For details on the various methods of data reading, see Section 11.2 on page 11-5.
- Manual logging of the gas level readings.

For details on the alarms and relays operation, see Chapter 10.

11.1.2.1 Method Drawbacks

The *alarm monitoring* method solves the response time inadequacy of the *periodic, visual monitoring* method (Section 11.1.1 on page 11-1), but does not provide any information to anticipate and prevent alarms.

Moreover, no information is available to immediately evaluate the severity of this alarm. For example, a rapid gas level increase and a daily trend increase trigger the same alarm. These two alarm conditions, however, do not have the same importance.

11.1.3 Analog Output Monitoring

The *analog output monitoring* (gas level monitoring via the analog output) solves the disadvantages of the *alarm monitoring* method (Section 11.1.2 on page 11-2) as follows:

- Connecting the analog output to a SCADA system. The Hydran 201Ti and the Hydran 201Ci-1 both have analog outputs that allow to monitor the gas level evolution.
- Using a SCADA system to generate alarms based on the collected data.
- Periodic, visual reading (weekly) of the gas level on the display of the H201Ti's or the H201Ci-1. For details on the various methods of data reading, see Section 11.2 on page 11-5.

It is recommended to use a SCADA system that offers the following advantages:

- Gas level reading from the control room.
- Regular processing data analysis.
- Detection of gas and fail alarms when the specified alarm conditions are present. The system's response time must be short enough for the application's needs.
- Safe storage of historic data in a format that allows easy analysis from a host computer.

11.1.3.1 Method Drawbacks

Analog outputs have the following disadvantages:

- Analog outputs are generally sensitive to electric noise. A special software must be used to compute the gas hourly and daily trends using “noisy” data.
- It is not possible to detect analog outputs that are out of calibration.
- An industrial-grade analog input and cables are necessary for each Hydran 201i System.
- Analog outputs carry only one type of information in only one direction: The level of dissolved gases in oil.
- In the following cases, the trend computations are interrupted and cannot be restarted before enough data are available again. For a 30-day trend, this represents a long time.
 - The analog output cable is broken.
 - The host computer loses contact with the analog output signal.
 - The host computer becomes “unavailable.”

Because of the above considerations, it is difficult to implement a reliable gas-trend alarm system based on the analog output signal.

11.1.3.2 Conclusion

Because of the above limitations and because it is not possible to change the Hydran 201i System's parameters from the control room, we can conclude that the *analog output monitoring* method (gas level monitoring via the analog output) still requires that a host computer be connected to the Hydran 201Ci Controller to retrieve the Hydran 201Ti's historic data and modify parameters.

11.1.4 Combined Alarm and Analog Output Monitoring

As the name implies, this method combines the two previous monitoring methods. The major advantage of this method is its familiarity. Its limits become apparent when one reads the text on the two previous methods:

- Although the gas level, the gas alarms (gas level, hourly trend and daily trend) and fail alarm are now available at the same time, important information is still confined to the Hydran 201Ti.
- Accessing the H201Ti is still required to modify operation parameters.
- The amount of cabling becomes an important issue. For each H201Ti, a minimum of four pairs of wires is required to connect the analog output, the two gas alarms and the fail alarm. To *receive* this information, three digital inputs and one analog input must be available in the SCADA system.

11.1.5 Local Monitoring With Host Computer

The *local monitoring with host computer* method consists of connecting a host computer running the Hydran Host software to a Hydran 201i System or a network using an RS-232 serial communication link.

Note: An RS-232 or USB communication port is available on each Hydran 201Ci Controller.

The Hydran Host software allows numerous tasks, among which:

- Data reading (gas level, hourly and daily trends, etc.)
- Immediate detection of all alarms and their acknowledgment by the user
- Modification of alarm settings and other parameters
- Historic data upload from one or several Hydran 201Ti's

For details, see the *Hydran Host Software Manual*.

Note: Other softwares can be run on the host computer at the same time as the Hydran Host software.

11.1.5.1 Method Benefits

The advantages of this method are as numerous as important:

- Gas level monitoring can be fully integrated to the transformer or station monitoring.
- Cabling is minimized.
- Reliability and performances are greater than those of methods based only on alarms and analog outputs monitoring.
- The use of networked electronic intelligent devices (such as the Hydran 201Ti and the Hydran 201Ci) is a mature technology with an extensive future.

11.1.6 Remote Monitoring With Host Computer

The *remote monitoring with host computer* method consists of connecting a host computer running the Hydran Host software to a Hydran 201i System or to one or several network(s) of Hydran 201i Systems located at different locations, through a telephone system and a modem link.

Remote monitoring offers the same features and benefits as local monitoring, plus:

- A modem can be connected to any Hydran 201i System in a local network. The modem is typically installed in any of the local network's Hydran 201Ci Controllers.
- The modem of the local network is connected to a telephone line.
- The host computer equipped with a modem and the Hydran Host software communicates with the Hydran 201i System network(s), thus simplifying the monitoring process.
- Each power station can have its own, independent network.
- The station can be entirely automated (unmanned).

11.2 DATA READING

Data (gas level, hourly and daily trends, alarm messages, etc.) can be read as follows:

- Direct reading using a Hydran 201Ti, a Hydran 201Ci controller or the Hydran Host software: See Section 11.2.1 on page 11-6.

- Reading of the Hydran 201i System's historic data (using the H201Ti or the Hydran Host software): See Section 11.2.2 on page 11-6.

11.2.1 Direct Data Reading

Data can be read directly as follows:

- *With the Hydran 201Ti*: Its user-interface includes a six-key keypad and a 2-line per 16-character display. For details, see Chapter 4.
- *With the Hydran 201Ci-1*: Its user-interface includes two illuminated push-buttons and a display, all mounted on the enclosure's door. Note that the H201Ci-1 does not provide the cause of the alarm.
- *With the Hydran Host software*: A host computer running General Electric Canada's Hydran Host software remains the easiest way to read data. The host computer screen provides an interaction far superior to the one of the H201Ti's user-interface. For details, see the *Hydran Host Software Manual*. The windows **Network Survey** and **Real Time Log Set-Up** can be used to monitor the data of up to 128 H201Ti's.

11.2.2 Historic Data Reading

The historic data simply consists of information (self-explanatory message, date and time of occurrence, etc.) recorded by and within the Hydran 201Ti when an event happens (alarm triggering, parameter modification by the user, etc.) or at fixed, adjustable logging rates.

Historic data can be read as follows:

- *With the H201Ti*: Simply access the **History** submenu with the H201Ti's keypad. For details, see Section 4.5.1 on page 4-12.
- *With the Hydran Host software*: The H201Ti's historic data can be accessed easily using General Electric Canada's Hydran Host software. Simply transfer the historic data from the H201Ti's toward the Hydran Host software with the **Express Download** button in the **Network Survey** window. The procedure is described in the *Hydran Host Software Manual*.

11.3 DATA ANALYSIS

The Hydran 201i System generates numerous data to assist in the early detection of incipient faults in transformers or other oil-filled equipment.

Other parameters (transformer load, oil temperature, dissolved gas analysis [DGA]) can also be useful in interpreting the gas level and trend evolutions. This information can even be used to comment the historic data (see the *Hydran Host Software Manual*).

An excellent source of information on the interpretation of gases in oil is the IEEE Standard C57.104-1991 “Guide for the Interpretation of Gases in Oil-Immersed Transformers.”

When interpreting the data of the Hydran 201i System, take the following points in consideration:

- An alarm can be triggered because of a misadjusted alarm set point. The historic data file Events indicates the modifications to the parameter settings (see Section 11.2.2 on page 11-6).
- An alarm (example: Low gas level) can be triggered following some maintenance procedure on the transformer, such as vacuum degassing of the oil.
- Daily load cycles and intermittent transformer operations both affect the Hydran 201Ti's gas level and hourly trend readings.

PAGE LEFT INTENTIONALLY BLANK

WARNING

Read all warnings and recommendations in Section 5.1 on page 5-1 before attempting one of the troubleshooting procedures listed in this Chapter.

The following useful references help to understand the instructions given in this Chapter:

- Alarms operation: See Chapter 10.
- Display of Hydran 201Ti's alarm messages: See Section 4.2.1 on page 4-3.

12.1 ALARM MESSAGES ON THE HYDRAN 201Ti'S DISPLAY

This Section contains, in alphabetical order, all alarm messages that can be displayed by the H201Ti:

- Battery L: See Section 12.1.1 on page 12-2.
- Battery LL: See Section 12.1.2 on page 12-2.
- CableOpen: See Section 12.1.3 on page 12-2.
- CableShort: See Section 12.1.4 on page 12-4.
- DayTrend H: See Section 12.1.5 on page 12-4.
- DayTrend HH: See Section 12.1.6 on page 12-5.
- DayTrend L: See Section 12.1.7 on page 12-5.
- DayTrend LL: See Section 12.1.8 on page 12-6.
- Gas H: See Section 12.1.9 on page 12-7.
- Gas HH: See Section 12.1.10 on page 12-7.
- Gas L: See Section 12.1.11 on page 12-7.
- Gas LL: See Section 12.1.12 on page 12-8.
- HourTrend H: See Section 12.1.13 on page 12-8.
- HourTrend HH: See Section 12.1.14 on page 12-8.
- HourTrend L: See Section 12.1.15 on page 12-9.
- HourTrend LL: See Section 12.1.16 on page 12-9.
- Replace SensNOW: See Section 12.1.17 on page 12-10.
- Replace SensSoon: See Section 12.1.18 on page 12-10.

- Sensor Not Inst!: See Section 12.1.19 on page 12-11.
- SensTemp H: See Section 12.1.20 on page 12-12.
- SensTemp HH: See Section 12.1.21 on page 12-12.
- SensTemp L: See Section 12.1.22 on page 12-13.
- SensTemp LL: See Section 12.1.23 on page 12-13.
- Setup Lost: See Section 12.1.24 on page 12-13.

12.1.1 Battery L

- *Alarm type*: Fail alarm
- *Non-abbreviated description*: Battery voltage Low
- *Priority*: Very low
- *Parameter(s) involved*:
 - **Batt. L; SysOK Relay;FaultTrig.** submenu; Section 4.5.7 on page 4-23
 - **Batt.Alr L** (alarm set point); **Service;VoltPile** submenu; Section 4.5.4.3 on page 4-20
 - **BattAlr Delay; Service;VoltPile** submenu; Section 4.5.4.3 on page 4-20
- *Alarm cause(s)*: Battery voltage below the **Batt.Alr L** alarm set point

Replace the battery within the next nine months. For details, see Section 2.7.1 on page 2-15.

12.1.2 Battery LL

- *Alarm type*: Fail alarm
- *Non-abbreviated description*: Battery voltage Low-Low
- *Priority*: Low
- *Parameter(s) involved*:
 - **Batt. LL; SysOK Relay;FaultTrig.** submenu; Section 4.5.7 on page 4-23
 - **Batt.Alr LL** (alarm set point); **Service;VoltPile** submenu; Section 4.5.4.3 on page 4-20
 - **BattAlr Delay; Service;VoltPile** submenu; Section 4.5.4.3 on page 4-20
- *Alarm cause(s)*: Battery voltage below the **Batt.Alr LL** alarm set point

Replace the battery within the next three months. For details, see Section 2.7.1 on page 2-15.

12.1.3 CableOpen

- *Alarm type*: Fail alarm

- *Non-abbreviated description:* Cable open (not connected)
- *Priority:* Very high (repair cable immediately)
- *Parameter(s) involved:*
 - **CableOpen; SysOK Relay; FaultTrig.** submenu; Section 4.5.7 on page 4-23
 - No set point nor delay
- *Alarm cause(s):* Faulty connection with one of the following cables:
 - Hydran 201 sensor cable
 - Sensor thermistor cable (reading of -75 °C [-103 °F] during one minute)
 - Heating plate thermistor cable (reading of -75 °C [-103 °F] during one minute)

Proceed as follows:

1. Identify the cable that triggers the alarm.
 - Verify whether the **SensorTemp** value in the **Temperature** submenu displays -75 °C (-103 °F). If so, the sensor thermistor cable (or a connector in the chain of connections) is the one causing the alarm.
 - Verify whether the **HeaterTemp** value in the extended **Temperature** submenu displays -75 °C (-103 °F). If so, the heating plate thermistor cable (or a connector in the chain of connections) is the one causing the alarm.
 - If the two above temperature readings are correct, execute the **ForceSensor Test** command in the **Service** submenu. If the result is different than **Good**, the sensor cable is probably the one causing the alarm.
2. Locate the corresponding cable and connectors in the Hydran 201Ti (see Section 2.4.6.2 on page 2-10).
3. Verify thoroughly the chain of connections for this cable, including the connectors.
4. Once the problem is fixed, execute the **ForceSensor Test** command in the **Service** submenu to reset the H201Ti and cancel the alarm.
5. Wait at least two minutes.
6. Verify that the alarm has disappeared.
7. If applicable, verify that the corresponding temperature has returned to a normal value.

12.1.4 CableShort

- *Alarm type:* Fail alarm
- *Non-abbreviated description:* Short-circuited cable
- *Priority:* Very high (repair cable immediately)
- *Parameter(s) involved:*
 - **CableShort; SysOK Relay; FaultTrig.** submenu; Section 4.5.7 on page 4-23
 - No set point nor delay
- *Alarm cause(s):* Faulty connection with one of the following cables:
 - Hydran 201 sensor cable
 - Sensor thermistor cable (reading of 200 °C [392 °F] during one minute)
 - Heating plate thermistor cable (reading of 200 °C [392 °F] during one minute)

Proceed as described for the **CableOpen** alarm (Section 12.1.3 on page 12-2), but replace the temperature values indicated in the text by the following one: 200 °C (392 °F).

12.1.5 DayTrend H

- *Alarm type:* Gas alarm
- *Non-abbreviated description:* Daily trend High
- *Priority:* Medium
- *Parameter(s) involved:*
 - **DayTrAlr H** (alarm set point); **Gas;DailyTrend** submenu; Section 4.5.2.3 on page 4-17
 - **DayTrAlr Delay; Gas;DailyTrend** submenu; Section 4.5.2.3 on page 4-17
- *Alarm cause(s):* Daily trend above the **DayTrAlr H** alarm set point

Proceed as follows:

1. Verify the daily trend calculated by the Hydran 201Ti. This value is displayed in the Main Display mode (see Section 4.2.2 on page 4-4) and also in the **DailyTrend** screen in the **Gas;DailyTrend** submenu (see Section 4.5.2.3 on page 4-17). If this value seems normal, verify whether the value of the alarm set point is adequate. This parameter was probably set to a value that is too low.
2. Verify the gas level measured by the H201Ti. This value is displayed in the Main Display mode (see Section 4.2.2 on page 4-4) and also in the **GasLevel** screen in the **Gas;GasLevel** submenu (see Section 4.5.2.1 on page 4-16). If this value seems

normal, verify whether the value of the alarm set point is adequate. This parameter was probably set to a value that is too low.

3. If the gas level value is abnormally too high and the alarm set point is set to an adequate value, verify the reading accuracy of the Hydran 201*i* System. Perform a dissolved gas analysis (DGA; see Section 13.2 on page 13-3).
4. If the gas level measured by the DGA corresponds to the H201Ti's reading, verify the equipment monitored by the H201Ti; follow the company regulations.
5. If the gas level readings are different (taking into account the accuracy of the apparatus and the method), execute the **ForceSensor Test** command in the **Service** submenu to test the operation of the Hydran 201 sensor. A problem may have occurred since the last automatic sensor test (which is performed the first and fifteenth days of each month at midnight).

12.1.6 DayTrend HH

- *Alarm type:* Gas alarm
- *Non-abbreviated description:* Daily trend High-High
- *Priority:* High
- *Parameter(s) involved:*
 - **DayTrAlr HH** (alarm set point); **Gas;DailyTrend** submenu; Section 4.5.2.3 on page 4-17
 - **DayTrAlr Delay; Gas;DailyTrend** submenu; Section 4.5.2.3 on page 4-17
- *Alarm cause(s):* Daily trend above the **DayTrAlr HH** alarm set point

Proceed as described for the **DayTrend H** alarm (Section 12.1.5 on page 12-4).

12.1.7 DayTrend L

- *Alarm type:* Fail alarm
- *Non-abbreviated description:* Daily trend Low
- *Priority:* Medium
- *Parameter(s) involved:*
 - **DayTrend L; SysOK Relay;FaultTrig.** submenu; Section 4.5.7 on page 4-23
 - **DayTrAlr L** (alarm set point); **Gas;DailyTrend** submenu; Section 4.5.2.3 on page 4-17
 - **DayTrAlr Delay; Gas;DailyTrend** submenu; Section 4.5.2.3 on page 4-17

- *Alarm cause(s)*: Daily trend below the **DayTrAlr L** alarm set point. Probably indicates a gas level reading problem.

Proceed as follows:

1. Verify the daily trend calculated by the Hydran 201Ti. This value is displayed in the Main Display mode (see Section 4.2.2 on page 4-4) and also in the **DailyTrend** screen in the **Gas;DailyTrend** submenu (see Section 4.5.2.3 on page 4-17). If this value seems normal, verify whether the value of the alarm set point is adequate. This parameter was probably set to a value that is too high.
2. Verify the gas level measured by the H201Ti. This value is displayed in the Main Display mode (see Section 4.2.2 on page 4-4) and also in the **GasLevel** screen in the **Gas;GasLevel** submenu (see Section 4.5.2.1 on page 4-16). If this value seems normal, verify whether the value of the alarm set point is adequate. This parameter was probably set to a value that is too high.
3. Verify whether the breathing membrane of the H201Ti's enclosure (item 4 in Figure 2-1 on page 2-3) and/or the one of the Hydran 201 sensor (see Figure 2-3 on page 2-6) are obstructed by paint, grease or other products.
4. Verify whether the valve on which the H201Ti is installed is open.
5. Execute the **ForceSensor Test** command in the **Service** submenu to test the operation of the H201 sensor. A problem may have occurred since the last automatic sensor test (which is performed the first and fifteenth days of each month at midnight).

12.1.8 DayTrend LL

- *Alarm type*: Fail alarm
- *Non-abbreviated description*: Daily trend Low-Low
- *Priority*: Medium
- *Parameter(s) involved*:
 - **DayTrend LL**; **SysOK Relay;FaultTrig.** submenu; Section 4.5.7 on page 4-23
 - **DayTrAlr LL** (alarm set point); **Gas;DailyTrend** submenu; Section 4.5.2.3 on page 4-17
 - **DayTrAlr Delay**; **Gas;DailyTrend** submenu; Section 4.5.2.3 on page 4-17
- *Alarm cause(s)*: Daily trend below the **DayTrAlr LL** alarm set point. Probably indicates a gas level reading problem.

Proceed as described for the **DayTrend L** alarm (Section 12.1.7 on page 12-5).

12.1.9 Gas H

- *Alarm type:* Gas alarm
- *Non-abbreviated description:* Gas level High
- *Priority:* Medium
- *Parameter(s) involved:*
 - **GasAlr H** (alarm set point); **Gas;GasLevel** submenu; Section 4.5.2.1 on page 4-16
 - **GasAlr Delay; Gas;GasLevel** submenu; Section 4.5.2.1 on page 4-16
- *Alarm cause(s):* Gas level above the **GasAlr H** alarm set point.

Perform steps 2 to 5 in Section 12.1.5 on page 12-4.

12.1.10 Gas HH

- *Alarm type:* Gas alarm
- *Non-abbreviated description:* Gas level High-High
- *Priority:* High
- *Parameter(s) involved:*
 - **GasAlr HH** (alarm set point); **Gas;GasLevel** submenu; Section 4.5.2.1 on page 4-16
 - **GasAlr Delay; Gas;GasLevel** submenu; Section 4.5.2.1 on page 4-16
- *Alarm cause(s):* Gas level above the **GasAlr HH** alarm set point.

Perform steps 2 to 5 in Section 12.1.5 on page 12-4.

12.1.11 Gas L

- *Alarm type:* Fail alarm
- *Non-abbreviated description:* Gas level Low
- *Priority:* Medium
- *Parameter(s) involved:*
 - **Gas L; SysOK Relay;FaultTrig.** submenu; Section 4.5.7 on page 4-23
 - **GasAlr L** (alarm set point); **Gas;GasLevel** submenu; Section 4.5.2.1 on page 4-16
 - **GasAlr Delay; Gas;GasLevel** submenu; Section 4.5.2.1 on page 4-16
- *Alarm cause(s):* Gas level below the **GasAlr L** alarm set point. Probably indicates a gas level reading problem.

Perform steps 2 to 5 in Section 12.1.7 on page 12-5.

12.1.12 Gas LL

- *Alarm type:* Fail alarm
- *Non-abbreviated description:* Gas level Low-Low
- *Priority:* Medium
- *Parameter(s) involved:*
 - **Gas LL; SysOK Relay; FaultTrig.** submenu; Section 4.5.7 on page 4-23
 - **GasAlr LL** (alarm set point); **Gas; GasLevel** submenu; Section 4.5.2.1 on page 4-16
 - **GasAlr Delay; Gas; GasLevel** submenu; Section 4.5.2.1 on page 4-16
- *Alarm cause(s):* Gas level below the **GasAlr LL** alarm set point. Probably indicates a gas level reading problem.

Perform steps 2 to 5 in Section 12.1.7 on page 12-5.

12.1.13 HourTrend H

- *Alarm type:* Gas alarm
- *Non-abbreviated description:* Hourly trend High
- *Priority:* Medium
- *Parameter(s) involved:*
 - **HourTrAlr H** (alarm set point); **Gas; HourlyTrend** submenu; Section 4.5.2.2 on page 4-16
 - **HourTrAlr Delay; Gas; HourlyTrend** submenu; Section 4.5.2.2 on page 4-16
- *Alarm cause(s):* Hourly trend above the **HourTrAlr H** alarm set point

Proceed as follows:

1. Verify the hourly trend calculated by the Hydran 201Ti. This value is displayed in the Main Display mode (see Section 4.2.2 on page 4-4) and also in the **HourlyTrend** screen in the **Gas; HourlyTrend** submenu (see Section 4.5.2.2 on page 4-16). If this value seems normal, verify whether the value of the alarm set point is adequate. This parameter is probably set to a value that is too low.
2. Perform steps 2 to 5 in Section 12.1.5 on page 12-4.

12.1.14 HourTrend HH

- *Alarm type:* Gas alarm
- *Non-abbreviated description:* Hourly trend High-High

- *Priority:* High
- *Parameter(s) involved:*
 - **HourTrAlr HH** (alarm set point); **Gas;HourlyTrend** submenu; Section 4.5.2.2 on page 4-16
 - **HourTrAlr Delay; Gas;HourlyTrend** submenu; Section 4.5.2.2 on page 4-16
- *Alarm cause(s):* Hourly trend above the **HourTrAlr HH** alarm set point

Perform step 1 in Section 12.1.13 on page 12-8, and then steps 2 to 5 in Section 12.1.5 on page 12-4.

12.1.15 HourTrend L

- *Alarm type:* Fail alarm
- *Non-abbreviated description:* Hourly trend Low
- *Priority:* Medium
- *Parameter(s) involved:*
 - **HourTrend L; SysOK Relay;FaultTrig.** submenu; Section 4.5.7 on page 4-23
 - **HourTrAlr L** (alarm set point); **Gas;HourlyTrend** submenu; Section 4.5.2.2 on page 4-16
 - **HourTrAlr Delay; Gas;HourlyTrend** submenu; Section 4.5.2.2 on page 4-16
- *Alarm cause(s):* Hourly trend below the **HourTrAlr L** alarm set point. Probably indicates a gas level reading problem.

Proceed as follows:

1. Verify the hourly trend calculated by the Hydran 201Ti. This value is displayed in the Main Display mode (see Section 4.2.2 on page 4-4) and also in the **HourlyTrend** screen in the **Gas;HourlyTrend** submenu (see Section 4.5.2.2 on page 4-16). If this value seems normal, verify whether the value of the alarm set point is adequate. This parameter was probably set to a value that is too high.
2. Perform steps 2 to 5 in Section 12.1.7 on page 12-5.

12.1.16 HourTrend LL

- *Alarm type:* Fail alarm
- *Non-abbreviated description:* Hourly trend Low-Low
- *Priority:* High

- *Parameter(s) involved:*
 - **HourTrend LL; SysOK Relay;FaultTrig.** submenu; Section 4.5.7 on page 4-23
 - **HourTrAlr LL** (alarm set point); **Gas;HourlyTrend** submenu; Section 4.5.2.2 on page 4-16
 - **HourTrAlr Delay; Gas;HourlyTrend** submenu; Section 4.5.2.2 on page 4-16
- *Alarm cause(s):* Hourly trend below the **HourTrAlr LL** alarm set point. Probably indicates a gas level reading problem.

Perform step 1 in Section 12.1.15 on page 12-9, and then steps 2 to 5 in Section 12.1.7 on page 12-5.

12.1.17 Replace SensNOW

- *Alarm type:* Fail alarm
- *Non-abbreviated description:* Replace Hydran 201 sensor immediately
- *Priority:* Very high
- *Parameter(s) involved:*
 - **SensRep Now; SysOK Relay;FaultTrig.** submenu; Section 4.5.7 on page 4-23
 - No set point nor delay
- *Alarm cause(s):* The sensor sensitivity has dropped significantly or the sensor is not functioning.

Replace sensor as soon as possible.

*Note: The Hydran 201Ti's H2O1 sensor is verified twice a month (the first and fifteenth days of the month at midnight); the relevant parameters are recorded in the historic data file Service. This test can also be performed manually using the **ForceSensor Test** command (in the **Service** submenu), but no results are recorded. In both cases, one of the two following messages is displayed if the test fails: **Replace SensSoon** or **Replace SensNOW**.*

12.1.18 Replace SensSoon

- *Alarm type:* Fail alarm
- *Non-abbreviated description:* Replace Hydran 201 sensor soon
- *Priority:* Medium
- *Parameter(s) involved:*
 - **SensRep Soon; SysOK Relay;FaultTrig.** submenu; Section 4.5.7 on page 4-23
 - No set point nor delay

- *Alarm cause(s)*: The sensor sensitivity has dropped or the sensor is not functioning.

Replace the sensor as soon as possible.

*Note: The Hydran 201Ti's H201 sensor is verified twice a month (the first and fifteenth days of the month at midnight); the relevant parameters are recorded in the historic data file Service. This test can also be performed manually using the **ForceSensor Test** command (in the **Service** submenu), but no results are recorded. In both cases, one of the two following messages is displayed if the test fails: **Replace SensSoon** or **Replace SensNOW**.*

12.1.19 Sensor Not Inst!

- *Alarm type*: Not applicable
- *Non-abbreviated description*: Hydran 201 sensor not installed
- *Priority*: Very high
- *Parameter(s) involved*: None
- *Alarm cause(s)*: Problem with the H201 sensor

This message can only be displayed following the execution of a **ForceSensor Test** command (see Section 4.5.4.2 on page 4-19).

Proceed as follows:

1. Ensure the serial numbers of the Hydran 201Ti (located at the back of the heating plate) and the H201 sensor (located under the sensor connector) correspond to those indicated on the shipping box and on the H201Ti's Test Certificate and Data Sheet. For an example of certificate, see Figure 6-1 on page 6-4.
2. Verify whether the **NewSensor** submenu (Section 4.5.8 on page 4-25) contains the value belonging to the corresponding H201 sensor.
3. Press **CHANGE** to "force" the installation of a new sensor.

Note: Each H201Ti is configured for a specific H201 sensor. If you receive more than one H201Ti's, take the necessary precautions to not interchange the H201 sensors and the H201Ti's.

12.1.20 SensTemp H

- *Alarm type:* Fail alarm
- *Non-abbreviated description:* Sensor temperature High
- *Priority:* Low
- *Parameter(s) involved:*
 - **SensTemp H; SysOK Relay; FaultTrig.** submenu; Section 4.5.7 on page 4-23
 - **STempAlr H** (alarm set point); **Temperature** submenu; Section 4.5.3 on page 4-17
 - **TempoAlr Delay; Temperature** submenu; Section 4.5.3 on page 4-17
- *Alarm cause(s):* Temperature of the Hydran 201 sensor above the **STempAlr H** alarm set point

Although the H201 sensor is not affected by the temperature, monitor its temperature regularly.

12.1.21 SensTemp HH

- *Alarm type:* Fail alarm
- *Non-abbreviated description:* Sensor temperature High-High
- *Priority:* Medium
- *Parameter(s) involved:*
 - **SensTemp HH; SysOK Relay; FaultTrig.** submenu; Section 4.5.7 on page 4-23
 - **STempAlr HH** (alarm set point); **Temperature** submenu; Section 4.5.3 on page 4-17
 - **TempoAlr Delay; Temperature** submenu; Section 4.5.3 on page 4-17
- *Alarm cause(s):* Temperature of the Hydran 201 sensor above the **STempAlr HH** alarm set point

WARNING

Exposing the H201 sensor to temperatures above the STempAlr HH alarm set point can damage the sensor.

Proceed as follows:

1. The oil is probably too hot at the location where the H201 sensor is installed; install the Hydran 201Ti at another location on the transformer tank, preferably at the bottom. For details on typical installations, see Section 5.2.2.2 on page 5-10.
2. If not already done, install the finned, high-temperature adaptor shown in Figure B-6 on page B-4; it can be purchased from General Electric Canada.

12.1.22 SensTemp L

- *Alarm type:* Fail alarm
- *Non-abbreviated description:* Sensor temperature Low
- *Priority:* Low
- *Parameter(s) involved:*
 - **SensTemp L; SysOK Relay; FaultTrig.** submenu; Section 4.5.7 on page 4-23
 - **STempAlr L** (alarm set point); **Temperature** submenu; Section 4.5.3 on page 4-17
 - **TempoAlr Delay; Temperature** submenu; Section 4.5.3 on page 4-17
- *Alarm cause(s):* Temperature of the Hydran 201 sensor below the **STempAlr L** alarm set point

Although the H201 sensor is not affected by the temperature, monitor its temperature regularly.

12.1.23 SensTemp LL

- *Alarm type:* Fail alarm
- *Non-abbreviated description:* Sensor temperature Low-Low
- *Priority:* Medium
- *Parameter(s) involved:*
 - **SensTemp LL; SysOK Relay; FaultTrig.** submenu; Section 4.5.7 on page 4-23
 - **STempAlr LL** (alarm set point); **Temperature** submenu; Section 4.5.3 on page 4-17
 - **TempoAlr Delay; Temperature** submenu; Section 4.5.3 on page 4-17
- *Alarm cause(s):* Temperature of the Hydran 201 sensor below the **STempAlr LL** alarm set point

The sensor sensitivity is very low; repair the Hydran 201Ti's heating system.

12.1.24 Setup Lost

- *Alarm type:* Fail alarm
- *Non-abbreviated description:* Lost setup (configuration)
- *Priority:* Very high
- *Parameter(s) involved:* None
- *Alarm cause(s):* See below

The **Setup Lost** alarm can be triggered by three causes. Each one is identified by a number displayed at the right of the message:

- (1) The value of at least one Hydran 201Ti's parameters is incorrect in the memory; in other words, the parameter has been changed, but not by a user.
 - Especially, verify the value of the **CheckSum** parameter in the **Service** submenu. For details, see Section 4.5.4.1 on page 4-18.
 - Because of this error, the default values are now the ones being used; verify carefully if the value of each parameter corresponds to your needs.
- (2) Sensor not installed.
- (4) Date anterior to 1996.

If two or all above causes trigger the alarm, the numbers are added up. For example, if, at the same time, a value is incorrect (1) and the date is anterior to 1996 (4), the number 5 (1 + 4) is displayed.

*Note: Each time the **Setup Lost** alarm is triggered, the **BattAlr Delay** parameter in the **Service** submenu (see Section 4.5.4.3 on page 4-20) is reset. This parameter must be set to the desired value after the alarm has disappeared.*

12.2 RS-232 AND/OR RS-485 COMMUNICATIONS

12.2.1 No Communication When the Host Computer is Connected Directly or by Modem to the Hydran 201Ti's DB-9 Connector

1. Ensure the H201Ti's **CommChannel** parameter (communication channel; **Communication** submenu; Section 4.5.6.1 on page 4-21) is set to **H201Ti-DB9**.
2. Ensure the H201Ti's **BaudRate** parameter (data transmission speed; **Communication** submenu) is identical to the one indicated in the Hydran Host software.
3. Ensure the H201Ti's **H201Ti ID** and **PowerStat. ID** parameters (identification numbers of the H201Ti and the power station; **Communication** submenu) are identical to the ones indicated in the Hydran Host software.
4. In the Hydran Host software, ensure the specified communication port is valid (COM1, COM2).
5. Verify the RS-232 link cable.

6. Ensure the modem's configuration string is correct.

12.2.2 No Communication When the Host Computer is Connected Directly or by Modem to the Hydran 201Ci Controller's DB-9 or USB Connector

1. Ensure the **CommChannel** parameter (communication channel; **Communication** submenu; Section 4.5.6.1 on page 4-21) of all Hydran 201Ti's connected to the H201Ci Controller is set to **Supervisory Link**.
2. Ensure the **BaudRate** parameter (data transmission speed; **Communication** submenu) of all H201Ti's connected to the H201Ci Controller is identical to the one indicated in the Hydran Host software.
3. Ensure the **H201Ti ID** and **PowerStat. ID** parameters (identification numbers of the H201Ti's and the power station; **Communication** submenu) of all H201Ti's connected to the H201Ci Controller are identical to the ones indicated in the Hydran Host software.
4. In the Hydran Host software, ensure the specified communication port is valid (COM1, COM2, etc.).
5. If the USB port is used, ensure the specified communication port is identical to the one associated by your computer to your USB link.
6. Verify the supervisory link cable.
7. Verify the RS-232 or USB link cable.
8. Verify the power supply and the operation of the H201Ci Controller.
9. Ensure the modem's configuration string is correct.

12.2.3 No Communication Between the Host Computer and the Network of Hydran 201i Systems

1. Connect the host computer to each Hydran 201Ci Controller and perform the tests listed in Section 12.2.2 on page 12-15.

2. Verify all RS-485 local network link cables.
3. Disconnect all RS-485 link cables and “rebuild” the network, one H201*Ci* Controller at a time. See Section 7.2.3 on page 7-4.

12.3 HYDRAN 201*Ci* CONTROLLER'S DISPLAY IS BLANK

1. If the fail alarm is triggered (and the analog outputs have dropped to 4.00 ± 0.10 mA), read the alarm message on the Hydran 201*Ti*'s display to identify the cause of the alarm. Then see Section 12.1 on page 12-1.
2. Verify the fuse(s) and power supply of the H201*Ci* Controller and H201*Ti*.
3. Verify the connections of the TDM signal at both ends of the supervisory link cable.
4. Verify the operation of the H201*Ci* Controller's display.

12.4 HYDRAN 201*Ti* AND HYDRAN 201*Ci* CONTROLLER'S ANALOG OUTPUTS AT ZERO

1. If the fail alarm is triggered (the H201*Ci* Controller's display is blank and the analog outputs have dropped to zero), read the alarm message on the H201*Ti*'s display to identify the cause of the alarm. Then see Section 12.1 on page 12-1.
2. Verify the fuses and power supply of the H201*Ci* Controller and H201*Ti*.
3. Verify the connections of the TDM signal at both ends of the supervisory link cable.
4. Verify the H201*Ti*'s analog output circuit by setting the H201*Ti*'s **AnalogMode** parameter (**Relays/Analog;Analog Out** submenu; see Section 4.5.7.4 on page 4-24) to **Force 50%** or **Force 100%**. Verify the result via the Hydran Host software or the SCADA system.
5. Verify the H201*Ci* Controller's analog output circuit by setting the H201*Ti*'s **TDM Mode** parameter (**Relays/Analog;TDM Out** submenu; see Section 4.5.7.5 on page 4-25) to **Force 50%** or **Force 100%**. Verify the result via the Hydran Host software or the SCADA system.

12.5 ALARMS

12.5.1 Fail Alarm Is Triggered

1. Read the alarm message on the Hydran 201Ti's display to identify the cause of the alarm. Then see Section 12.1 on page 12-1.
2. Verify the fuses and power supply of the Hydran 201Ci Controller and H201Ti.
3. Verify the connections of the TDM signal at both ends of the supervisory link cable.

12.5.2 Fail Alarm Message Displayed in the Hydran Host Software

1. Display the on-line help of the alarm message window to identify the cause of the alarm.
2. For the procedure, see Section 12.1 on page 12-1.

12.5.3 Intermittent Gas Alarms Are Occurring

1. Alarm set points are too low. Consult the Hydran 201Ti's historic data files Short Term and Long Term.
2. Compare the set points with the variations of gas level, hourly trend and daily trend.
3. Verify the H201Ti's gas alarm delays.

12.5.4 An Alarm Relay Does Not Reset, Even If the Alarm Condition Has Disappeared

1. The corresponding alarm delay has not yet expired.
2. The **RelayMode** parameter (**Relays/Analog** submenu; Section 4.5.7 on page 4-23) of the Hydran 201Ti's corresponding relay is set to **Force ON** or **Force OFF**.
3. The **RelayMode** parameter of the H201Ti's corresponding relay is set to **Latch**. The alarm must be acknowledged using the H201Ti's keypad (and the alarm condition must have disappeared) to cancel the alarm.

4. Verify the relay's contacts and the circuit by setting the corresponding **RelayMode** parameter to **Force ON** and **Force OFF** in the H201Ti's **Relays/Analog** submenu.

12.5.5 Irregular Gas Readings

1. Ensure the valve (on which the Hydran 201Ti is installed) is fully open.
2. Confirm that the valve type is acceptable (full bore, gate or ball, no restriction between valve and tank). See the recommendations in Section 5.1 on page 5-1.
3. Verify the Hydran 201 sensor's serial number and parameters in the H201Ti's **Service;SensorCal Data** submenu (Section 4.5.4.1 on page 4-18).
4. Execute the H201Ti's **ForceSensor Test** command (**Relays/Analog** submenu) to test sensor operation.
5. Verify the value of the **HourlyTr Period** parameter (period of the hourly trend; **Gas;HourlyTrend** submenu).
6. Verify the value of the **DailyTr Period** parameter (period of the daily trend; **Gas;DailyTrend** submenu).
7. Verify the value of the **Period B** parameter (**Temperature;DynOil Sampl** submenu).
8. Verify the parameters pertaining to the sensor temperature (**Temperature** submenu).
9. Consult General Electric Canada to optimize the value of the parameters and the location of the H201 sensor.

12.5.6 Inaccurate Gas Readings

1. Verify the transformer's level of fault gases-in-oil by performing a dissolved gas analysis (DGA; see Section 13.2 on page 13-3).
2. Ensure the valve (on which the Hydran 201Ti is installed) is fully open.
3. Confirm that the valve type is acceptable (full bore, gate or ball, no restriction between valve and tank). See the recommendations in Section 5.1 on page 5-1.

4. Verify the Hydran 201 sensor's serial number and parameters in the H201Ti's **Service;SensorCal Data** submenu (Section 4.5.4.1 on page 4-18).
5. Execute the H201Ti's **ForceSensor Test** command (**Relays/Analog** submenu) to test the sensor operation.
6. Verify the parameters pertaining to the sensor temperature (**Temperature** submenu).
7. Consult General Electric Canada to optimize the value of the parameters and the location of the H201 sensor.

12.5.7 Gas Level Reading Is Abnormally High

See Section 12.1.9 on page 12-7.

12.5.8 Gas Level Reading Is Slowly Decreasing Toward Zero

See Section 12.1.15 on page 12-9.

PAGE LEFT INTENTIONALLY BLANK

The maintenance schedule suggested in this Chapter provides optimum performance and reliability from the Hydran 201*i* System. The maintenance routines should be performed in fair weather.

WARNING

All procedures in this manual must be strictly adhered to. Any deviation from these could cause irreversible damages to the transformer being monitored and/or the Hydran 201*i* System, and could lead to property damage, personal injury and/or death. Installation and maintenance of the Hydran 201*i* System must be carried out by qualified personnel only.

Note: Some steps in the maintenance procedures described in this Chapter may not apply, depending on the option(s) installed.

WARNING

Before proceeding with any maintenance operation, review the local safety regulations. Read all the warnings and recommendations in Section 5.1 on page 5-1.

The person in charge of maintenance must already be familiar enough with the Hydran 201*i* System to:

- Use and set the Hydran 201Ti's parameters with its keypad.
- Use the Hydran 201Ci Controller and communicate with it.
- Use General Electric Canada's Hydran Host software.

If not, reviewing the previous chapters helps in performing maintenance routines. Also, consult the *Hydran Host Software Manual*.

Table 13-1 on page 13-2 summarizes the maintenance routines and their frequency. Each routine is explained in detail in the Section indicated in the table.

Table 13-1 - Maintenance Routines and Their Frequency

Routine	Frequency
Historic data verification (Section 13.1 on page 13-2)	Annually or on alarm
Dissolved gas analysis (DGA; Section 13.2 on page 13-3)	
Hydran 201Ti verification (Section 13.3 on page 13-4): <ul style="list-style-type: none"> • Visual inspection • LED's, heater, display and keypad verification (Section 6.2.2 on page 6-7) • Parameter verification (alarm set points, etc.) • Alarm relays verification (Section 6.2.4 on page 6-9) • Verification of sensor tests^a (Section 6.2.6 on page 6-12) • Analog output verification (if connected; Section 6.2.8 on page 6-14) 	Annually or on fail alarm
Hydran 201Ci Controller verification (Section 13.4 on page 13-6): <ul style="list-style-type: none"> • Visual inspection • LED's, heater and display verification (Section 8.2.2 on page 8-3) • Hydran 201Ci-1's analog output verification (if connected; Section 8.2.3 on page 8-4) • H201Ci-1's alarm relays verification (if connected; Section 8.2.4 on page 8-6) • RS-232 or USB and RS-485 communications verification (Section 7.2.3 on page 7-4) 	

a. The H201Ti's sensor is tested automatically twice a month, and the results are stored in the historic data file Service.

13.1 HISTORIC DATA VERIFICATION

Frequency: Annually or on alarm

In addition to the annual or on-alarm verification, the Hydran 201Ti's historic data must also be read regularly by the user.

If the data is read from the H201Ti, follow the instructions in Section 4.5.1 on page 4-12. The data can be collected using a host computer running the Hydran Host software (see the *Hydran Host Software Manual*).

The historic data are verified as follows:

1. Consult the historic data file Events to investigate suspicious alarms and other events.
2. Consult the historic data files Short Term and Long Term to study the evolution of the gas level and the hourly and daily trends.
3. Ensure the hourly and daily trends periods are optimized. Change the values if necessary.
4. Examine every alarm setting. Change the values if necessary.

Note: Alarm settings should be modified by authorized personnel only.

13.2 DISSOLVED GAS ANALYSIS (DGA)

Frequency: Annually (minimum) or on alarm

The dissolved gas analysis (DGA) is the reference method used to determine the exact level of dissolved gases in oil. A DGA should be performed at least once a year.

To verify the readings of the Hydran 201i System using a DGA, proceed as follows:

1. Note the Hydran 201Ti's gas level reading.
2. Take an oil sample from the Hydran 201 sensor's sampling port (see Appendix H).
3. Send the sample to a qualified laboratory.

The DGA results include the concentrations, in parts per million (ppm), of the following gases:

- Hydrogen (H₂)
- Carbon monoxide (CO)
- Acetylene (C₂H₂)
- Ethylene (C₂H₄)

- Methane (CH₄)
- Ethane (C₂H₆)
- Carbon dioxide (CO₂)
- Nitrogen (N₂)
- Oxygen (O₂)

The Hydran 201i System gives a composite reading of the first four gases in the above list, in other words the gases generated by transformer incipient faults. This reading can be compared to the DGA results using the following formula:

$$\text{H201Ti reading} = 100 \% [\text{H}_2] + 18 \% [\text{CO}] + 8 \% [\text{C}_2\text{H}_2] + 1.5 \% [\text{C}_2\text{H}_4]$$

A few examples are given in Table 13-2 on page 13-4. The difference between the actual and the calculated readings should fall within the technical specifications of the Hydran 201i System.

Table 13-2 - Examples of Gas Reading Comparisons Between a DGA and a Hydran 201Ti

Dissolved Gas Analysis (DGA) (ppm)				H201Ti Reading (ppm)
Hydrogen (H₂)	Carbon Monoxide (CO)	Acetylene (C₂H₂)	Ethylene (C₂H₄)	
100	0	0	0	100
100	1000	0	0	280
100	100	0	0	118
100	100	50	0	122
100	100	50	200	125

13.3 HYDRAN 201Ti VERIFICATION

Frequency: Annually or on fail alarm

Note: Alarms are triggered during this verification procedure. Please warn the appropriate personnel.

WARNING

Read the precautions listed in Section 5.1 on page 5-1 before handling the Hydran 201 sensor.

The H201Ti is verified as follows:

1. Check for oil leaks.
2. If necessary, clean and retighten the brass adaptor and the H201 sensor.
3. Check for loose connections on the terminal blocks and connectors. Retighten if necessary.

WARNING ac power supply voltage is present on most terminals.

4. Verify the LED's, the heater, the display and the keypad by performing the procedure in Section 6.2.2 on page 6-7.
5. Using the H201Ti's keypad or a host computer running the Hydran Host software (see the *Hydran Host Software Manual*), verify the date and time in the **Date&Time** submenu (Section 4.5.5 on page 4-21) by performing the procedure in Section 6.4.9 on page 6-34. If they must be adjusted, see Section 6.2.3 on page 6-8.
6. Verify the four parameters in the **History;HistoSetup** submenu (Section 4.5.1.5 on page 4-15). If they must be adjusted, see Section 6.4.2 on page 6-31.
7. Verify the parameters in the **Gas** submenu (Section 4.5.2 on page 4-16). If they must be adjusted, see Section 6.4.3 on page 6-31.
8. Verify the parameters in the **Temperature** submenu (Section 4.5.3 on page 4-17). If they must be adjusted, see Section 6.4.5 on page 6-32.
9. Verify the **Period A** and **Period B** parameters in the **Temperature;DynOil Sampl** submenu.
10. Verify the **SerialNumber**, the ten H201 sensor parameters and the **Checksum** (all in the **Service;SensorCal Data** submenu, Section 4.5.4.1 on page 4-18) correspond to those written on the Test Certificate and Data Sheet (see an example in Figure 6-1 on page 6-4). If those parameters must be adjusted, see Section 6.4.6 on page 6-33.

11. Verify the parameters (only accessed using the H201Ti's keypad) in the **Communication** submenu (Section 4.5.6 on page 4-21) by performing the procedure in Section 6.4.10 on page 6-34. If they must be adjusted, see Section 6.4.1 on page 6-30.
12. Verify the operation mode of the TDM signal in the **Relays/Analog;TDM Out** submenu (Section 4.5.7.5 on page 4-25).
13. If the H201Ti's alarm contacts are used (connected to a SCADA system), verify the alarm relays by performing the procedure in Section 6.2.4 on page 6-9.

Note: Generally, the SCADA system is connected to the alarm contacts of the Hydran 201Ci Controller.

14. Verify the battery voltage and the other parameters in the **Service;Battery** submenu. (Section 4.5.4.3 on page 4-20) by performing the procedure in Section 6.2.5 on page 6-12. If they must be adjusted, see Section 6.4.7 on page 6-33.
15. Verify the sensor serial number and perform a sensor test, as described in Section 6.2.6 on page 6-12.
16. If the analog output is used (connected to a SCADA system), verify it by performing the procedure in Section 6.2.8 on page 6-14.

Note: Generally, the SCADA system is connected to the analog outputs of the H201Ci Controller.

17. If an RS-232 link is used, verify it by performing the procedure in Section 6.2.9 on page 6-15.

13.4 HYDRAN 201Ci CONTROLLER VERIFICATION

Frequency: Annually or on fail alarm

Note: Alarms are triggered during this verification procedure. Please warn the appropriate personnel.

The H201Ci is verified as follows:

1. Check for water or dust infiltration inside the enclosure.

2. If necessary, clean and fix the enclosure.
3. Check for loose connections on the terminal blocks and connectors. Retighten if necessary.

WARNING ac power supply voltage is present on most terminals.

4. Verify the LED's, the heater and the display by performing the procedure in Section 8.2.2 on page 8-3.
5. Verify the Hydran 201Ci-1's analog output by performing the procedure in Section 8.2.3 on page 8-4.
6. If the H201Ci-1 is not currently in operation and if its alarm contacts are used (connected to a SCADA system), verify the alarm indicators and relays by performing the procedure in Section 8.2.4 on page 8-6.
7. Verify the RS-232 or USB and RS-485 communications by performing the procedure in Section 7.2.3 on page 7-4.

13.5 FUSE

The Hydran 201Ti, the Hydran 201Ci-C and the Hydran 201Ci-1 require the following type of fuse:

- 5 A
- 250 Vac
- Time delay
- 5 x 20 mm
- Slow blow

PAGE LEFT INTENTIONALLY BLANK

Technical Specifications for the Hydran 201*i* System

A.1 HYDRAN 201T*i* INTELLIGENT TRANSMITTER

GENERAL

Description	Continuous, on-line, intelligent gas-in-oil transmitter
Components	Sensor and electronic modules housed in cylindrical enclosure
Gas Response	Hydrogen (H ₂), carbon monoxide (CO), acetylene (C ₂ H ₂), ethylene (C ₂ H ₄)
Medium	Mineral, insulating oil for transformers
Application	Transformer monitoring; specifically, detection of incipient faults in oil-filled, electrical equipment

ANALYTICAL PERFORMANCE

Principle	Gas-permeable membrane and combustible gas detector
Sampling Method	Flooded port with 1-in NPT male threads
Measurement Range	0–2,000 ppm (volume/volume, H ₂ equivalent); other ranges are available
Accuracy	For 0–2,000 ppm range: ± 10 % of reading ± 25 ppm (H ₂ equivalent)
Relative Sensitivity	<ul style="list-style-type: none">• H₂: 100 % of concentration• CO: 18 ± 3 % of concentration• C₂H₂: 8 ± 2 % of concentration• C₂H₄: 1.5 ± 0.5 % of concentration
Response Time	10 minutes (90 % of step change)
External Sampling Port	Designed for glass syringe with Luer stop cock; closed with 5/32-in Allen screw

ELECTRONIC UNIT

Hardware	Microprocessor; watchdog; clock
Software	Real-time operating system; menu-driven interface
Functions	<ul style="list-style-type: none">• Gas level, hourly trend and daily trend readings• Gas level, gas trends and fail alarms• History logging• Periodic sensor test• Calibration, configuration and self-test• Networking• Remote control via Hydran 201C<i>i</i> Controller (optional modem)• Remote, embedded software upgrading
Communications	User selection (one port at a time): <ul style="list-style-type: none">• RS-232 link (DB-9 connector) to connect host computer• Supervisory link to connect H201C<i>i</i> Controller

Display	Backlit liquid crystal display (LCD); 2 lines x 16 characters
Keypad	6 keys: ENTER, UP, DOWN, CHANGE, ESC and END
Alarm Contacts	<ul style="list-style-type: none">• Gas High, gas High-High and Fail• One NO and one NC contacts (type C) per alarm• 1,250 VA @ 240 Vac; rated current: 5 A
Analog Output	Isolated 4–20 mA; 0–2,000 ppm range; isolation 2,000 V RMS; 10 V load maximum; 500 Ω @ 20 mA

MISCELLANEOUS

Enclosure	Type NEMA 4X; white, cylindrical aluminum housing; 186 mm (7.3 in) diameter x 180 mm (7 1/8 in)
Electronic Modules	Totally-encased CPU and I/O modules
Enclosure Heating/Cooling	325-W heating plate; convection cooling; maintain unit between 15 and 65 °C (59 and 149 °F)
Brass Adaptor	With 1.5-in male NPT threads (standard); mounting on transformer valve; other dimensions are available
Temperatures	<ul style="list-style-type: none">• Oil at the valve: -40 to +90 °C (-40 to +194 °F)• With finned, high-temperature adaptor (1.5-in male threads only) for oil temperatures up to 105 °C (221 °F)• Ambient: -40 to +55 °C (-40 to +131 °F)• Storage: 5–45 °C (41–113 °F) <p><i>Note: At low temperatures, the LCD display might not be legible, but all other functionalities are fully operational.</i></p>
Oil Pressure	Vacuum-resistant sensor; withstands 0–700 kPa (0–100 psi)
Power Supply	<ul style="list-style-type: none">• Rated voltage: 90–132 Vac or 180–264 Vac, 47–63 Hz• Rated power: 475 VA maximum
Standards Met	<ul style="list-style-type: none">• CISPR 11: Measurement of radiated and conducted emissions• IEC 60068-2-1: Environmental testing at cold temperature• IEC 60068-2-2: Environmental testing at dry heat temperature• IEC 60255-5: Insulation coordination for measuring relays and protection equipment• EN 61000-4-2: ESD immunity• EN 61000-4-3: Radiated electromagnetic field immunity – radio frequencies• EN 61000-4-4: Electrical fast transient/burst immunity• EN 61000-4-5: Surge immunity• EN 61000-4-6: Immunity to conducted disturbance induced by radio-frequency fields• EN 61000-4-8: Power frequency magnetic field immunity• EN 61000-4-11: Voltage dips, short interruptions and voltage variations immunity (applicable for ac power supply only)• EN 61010-1: Product safety
Safety Conditions	Designed to be safe at least under the following conditions: <ul style="list-style-type: none">• Altitude up to 2,000 m• Enclosure at temperatures ranging from -40 to +55 °C (-40 to +131 °F) and at relative humidities of 95 % or less

- Weight**
- Installed: 5.6 kg (12 lb)
 - Shipping: 6.9 kg (15 lb)

Hydran Host Supports all H201Ti functions plus networking and embedded software

Software upgrading; available in Microsoft Windows version

Note: General Electric Canada has made every reasonable attempt to ensure the completeness and accuracy of these technical specifications. However, the information contained in these technical specifications is subject to change without notice, and does not represent a commitment on the part of General Electric Canada.

A.2 HYDRAN 201Ci-C COMMUNICATIONS CONTROLLER

GENERAL

- Description** Remote controller for one to four Hydran 201Ti's; manages communications, including networking
- Components** Electronic unit housed in a waterproof enclosure, suitable for outdoor installation
- Application** Supervision of one to four H201Ti's and/or a network of up to 128 H201Ti's via a single RS-232 or USB port, either locally or remotely through an optional modem
-

ELECTRONIC UNIT

- Functions** Management of communications transmitted from:
- H201Ti's (supervisory link)
 - H201Ci Controllers (H201Ci-C's and/or H201Ci-1's) in the network (RS-485 link)
 - A host computer (RS-232 or USB link)
- Display** None
- Analog Outputs** None
- Alarm Contacts** None
-

COMMUNICATIONS/NETWORKING

- Supervisory Link**
- Connects with one H201Ti
 - 2,000-V RMS isolated
 - A 2-twisted-pairs (16 or 18 AWG) cable with overall shield is required per H201Ti
 - Maximal length (all cables added up): 1,200 m (4,000 ft)
 - Power supply: Separate, isolated, impedance-protected, +15 Vdc
- RS-485 Local Network Link (Isolated)**
- Standard RS-485 communication port allows daisy-chaining of up to 32 H201Ci Controllers (H201Ci-C's and/or H201Ci-1's) via the Main Terminal Block
 - One twisted triad (16 or 18 AWG) with overall shield required
 - Maximal total daisy-chain length: 1,200 m (4,000 ft)
- RS-232 or USB Link**
- Standard RS-232 port (DB-9 connector), or standard USB link (type-B connector)
 - Allows serial communications with a local host computer (or remotely with optional modem)
 - Any H201Ti can be accessed through any H201Ci Controller in the local network
- Recommendation** Run all communication cables in flexible or rigid, metallic conduits for maximum mechanical and electrical protection
-

MISCELLANEOUS

Enclosure Type NEMA 4X steel enclosure; baked enamel; textured white finish

Dimensions 244.5 x 349.3 x 157.7 mm (9 5/8 x 13 3/4 x 3 3/16 in)

Operating Temperature -40 to +55 °C (-40 to +131 °F) with standard internal heater

Power Supply • Rated voltage: 90–132 Vac or 180–264 Vac, 47–63 Hz
• Rated power: 145 VA maximum

Standards Met • CISPR 11: Measurement of radiated and conducted emissions
• IEC 60068-2-1: Environmental testing at cold temperature
• IEC 60068-2-2: Environmental testing at dry heat temperature
• IEC 60255-5: Insulation coordination for measuring relays and protection equipment
• EN 61000-4-2: ESD immunity
• EN 61000-4-3: Radiated electromagnetic field immunity – radio frequencies
• EN 61000-4-4: Electrical fast transient/burst immunity
• EN 61000-4-5: Surge immunity
• EN 61000-4-6: Immunity to conducted disturbance induced by radio-frequency fields
• EN 61000-4-8: Power frequency magnetic field immunity
• EN 61000-4-11: Voltage dips, short interruptions and voltage variations immunity (applicable for ac power supply only)
• EN 61010-1: Product safety

Safety Conditions Designed to be safe at least under the following conditions:

- Altitude up to 2,000 m
- Enclosure at temperatures ranging from -40 to +55 °C (-40 to +131 °F) and at relative humidities of 95 % or less

Weight • Installed: 6.6 kg (15 lb)
• Shipping: 7.5 kg (17 lb)

Hydran Host Software Supports all H201Ti functions plus networking and embedded software upgrading; available in Microsoft Windows version

Note: General Electric Canada has made every reasonable attempt to ensure the completeness and accuracy of these technical specifications. However, the information contained in these technical specifications is subject to change without notice, and does not represent a commitment on the part of General Electric Canada.

A.3 HYDRAN 201Ci-1 ONE-CHANNEL CONTROLLER

GENERAL

- Description** Remote controller for one Hydran 201Ti; provides network communications capabilities, a gas level digital display, alarm contacts, alarm indicators and an isolated, analog output
- Components** Electronic unit housed in a waterproof enclosure, suitable for outdoor installation
- Application** Supervision of one H201Ti and/or a network of up to 128 H201Ti's via a single RS-232 or USB port, either locally or remotely through an optional modem
-

ELECTRONIC UNIT

- Display** Digital, light-emitting diodes (LED's); 0–1999 ppm scale
- Isolated, Analog Output** 4–20 mA, 0–2000 ppm range
- Gas Alarms** High and High-High alarms duplicate alarms in H201Ti: Gas level, hourly and daily trends
- Fail Alarm** Duplicates alarm in H201Ti: Power failure, loss of communications, sensor and other system malfunctions; upon system fault, analog outputs are set to zero and display is blanked
- Alarm Contacts**
- Gas High, gas High-High and Fail
 - One NO and one NC contacts (type C) per alarm
 - 1,250 VA @ 240 Vac; rated current: 5 A
- Illuminated Push-Buttons (Alarm Indicators)**
- 2 illuminated door-mounted push-buttons (gas High and High-High alarms)
 - Latched on when corresponding alarm condition is detected
 - Turned off by pushing button when alarm condition is cleared
-

COMMUNICATIONS/NETWORKING

- Supervisory Link**
- Connects with one H201Ti
 - 2,000-V RMS isolated
 - 3-twisted-pairs (16 or 18 AWG) cable with overall shield required
 - Maximal length: 1,200 m (4,000 ft)
 - Power supply: Separate, isolated, impedance-protected, +15 Vdc
- RS-485 Local Network Link (Isolated)**
- Standard RS-485 communication port allows daisy-chaining of up to 32 H201Ci Controllers (H201Ci-C's and/or H201Ci-1's) via the Main Terminal Block
 - One twisted triad (16 or 18 AWG) with overall shield required
 - Maximal total daisy-chain length: 1,200 m (4,000 ft)
- RS-232 or USB Link**
- Standard RS-232 port (DB-9 connector), or standard USB link (type-B connector)
 - Allows serial communications with a local host computer (or remotely with optional modem)
 - Any H201Ti can be accessed through any H201Ci Controller in the local network
-

Recommendation Run all communication cables in flexible or rigid, metallic conduits for maximal mechanical and electrical protection

MISCELLANEOUS

Enclosure Type NEMA 4X steel enclosure; baked enamel; textured white finish

Dimensions 244.5 x 349.3 x 157.7 mm (9 5/8 x 13 3/4 x 3 3/16 in)

Operating Temperature -40 to +55 °C (-40 to +131 °F) with standard internal heater

Power Supply

- Rated voltage: 90–132 Vac or 180–264 Vac, 47–63 Hz
- Rated power: 160 VA maximum

Standards Met

- CISPR 11: Measurement of radiated and conducted emissions
- IEC 60068-2-1: Environmental testing at cold temperature
- IEC 60068-2-2: Environmental testing at dry heat temperature
- IEC 60255-5: Insulation coordination for measuring relays and protection equipment
- EN 61000-4-2: ESD immunity
- EN 61000-4-3: Radiated electromagnetic field immunity – radio frequencies
- EN 61000-4-4: Electrical fast transient/burst immunity
- EN 61000-4-5: Surge immunity
- EN 61000-4-6: Immunity to conducted disturbance induced by radio-frequency fields
- EN 61000-4-8: Power frequency magnetic field immunity
- EN 61000-4-11: Voltage dips, short interruptions and voltage variations immunity (applicable for ac power supply only)
- EN 61010-1: Product safety

Safety Conditions Designed to be safe at least under the following conditions:

- Altitude up to 2,000 m
- Enclosure at temperatures ranging from -40 to +50 °C (-40 to +122 °F) and at relative humidities of 95 % or less

Weight

- Installed: 6.8 kg (15 lb)
- Shipping: 7.7 kg (17 lb)

Hydran Host Software Supports all H201Ti functions plus networking and embedded software upgrading; available in Microsoft Windows version

Note: General Electric Canada has made every reasonable attempt to ensure the completeness and accuracy of these technical specifications. However, the information contained in these technical specifications is subject to change without notice, and does not represent a commitment on the part of General Electric Canada.

PAGE LEFT INTENTIONALLY BLANK

Mechanical Drawings

B.1 HYDRAN 201Ti INTELLIGENT TRANSMITTER

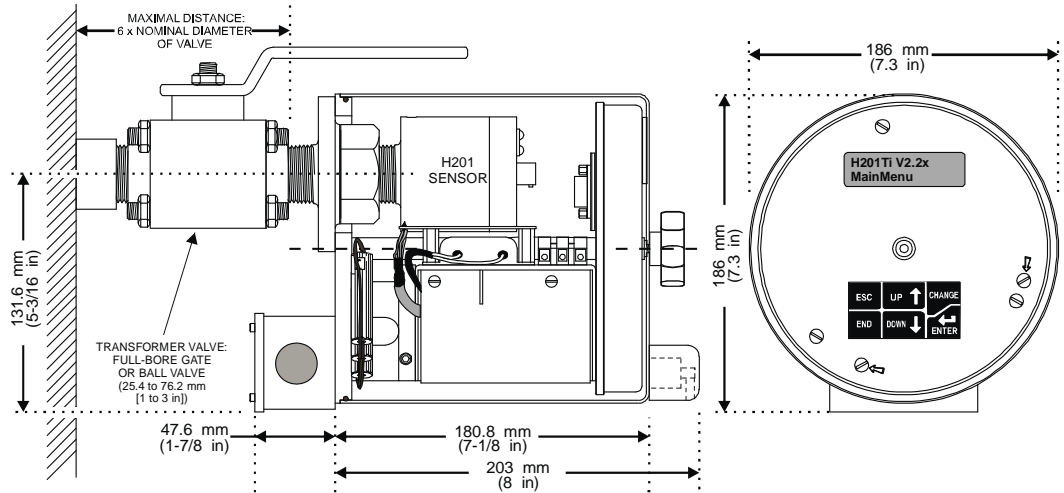

Figure B-1 - Hydran 201Ti Dimensions

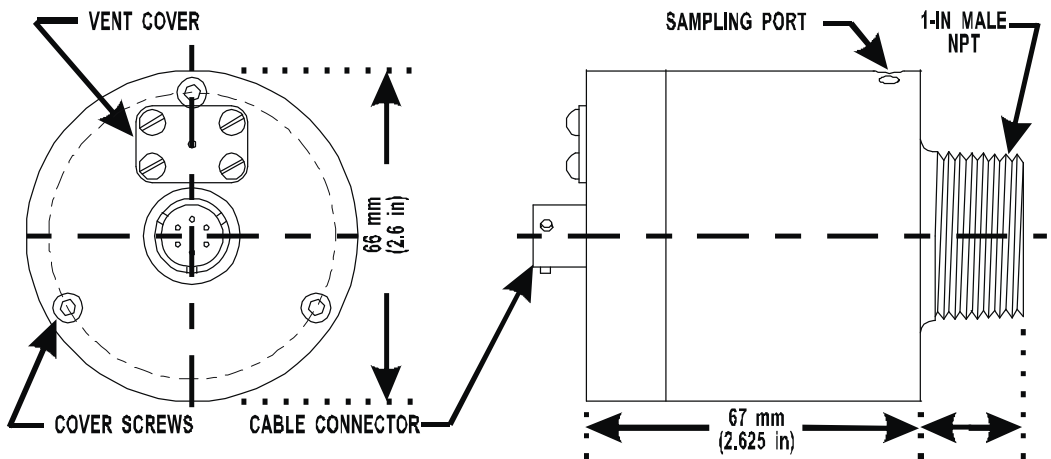

Figure B-2 - Hydran 201 Sensor

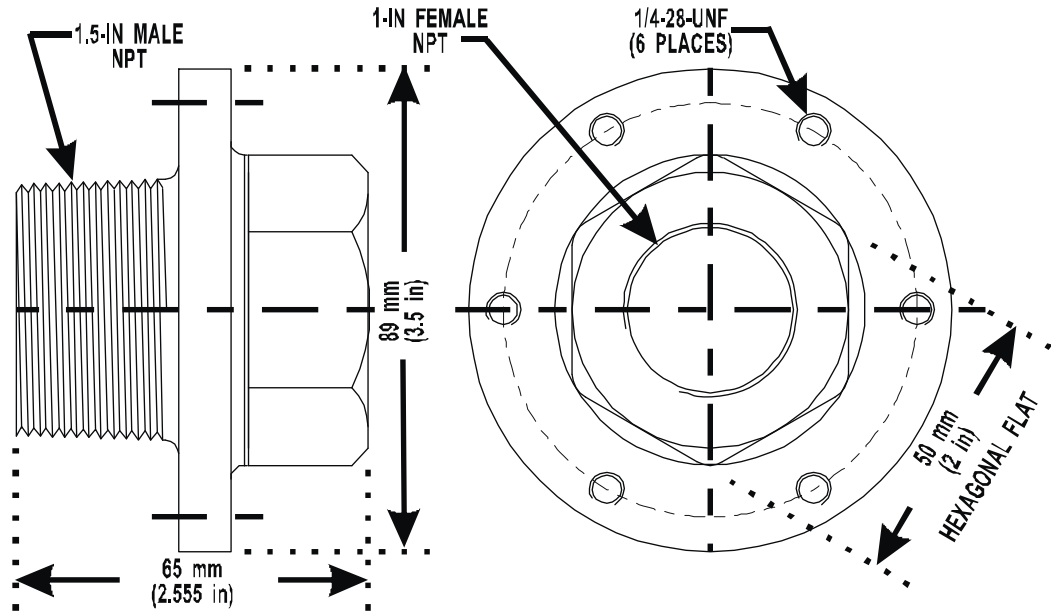

Figure B-3 - 1.5-In Adaptor

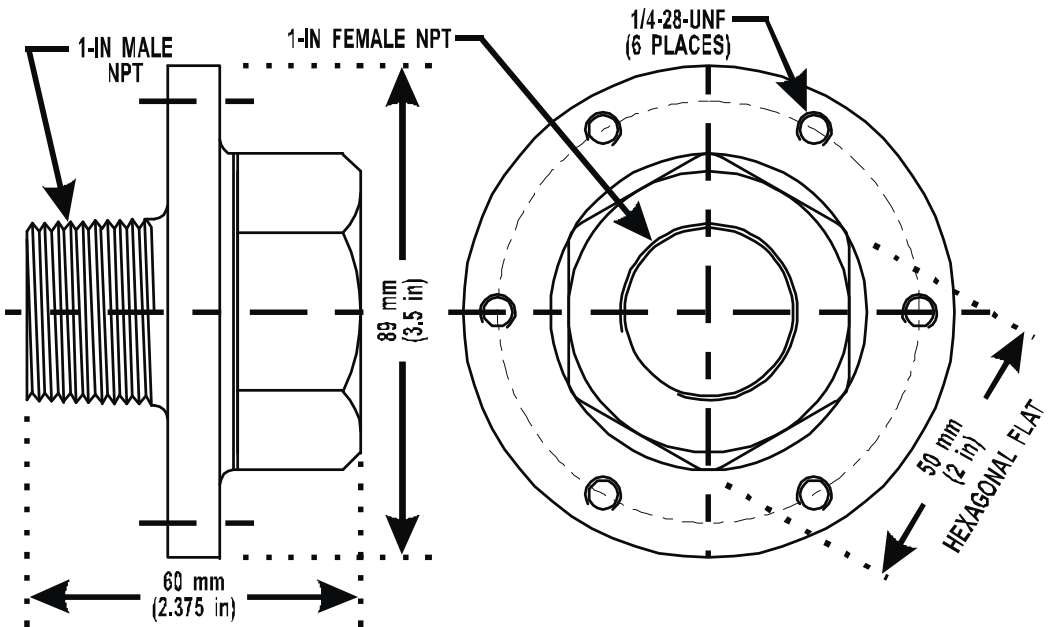

Figure B-4 - 1-In Adaptor

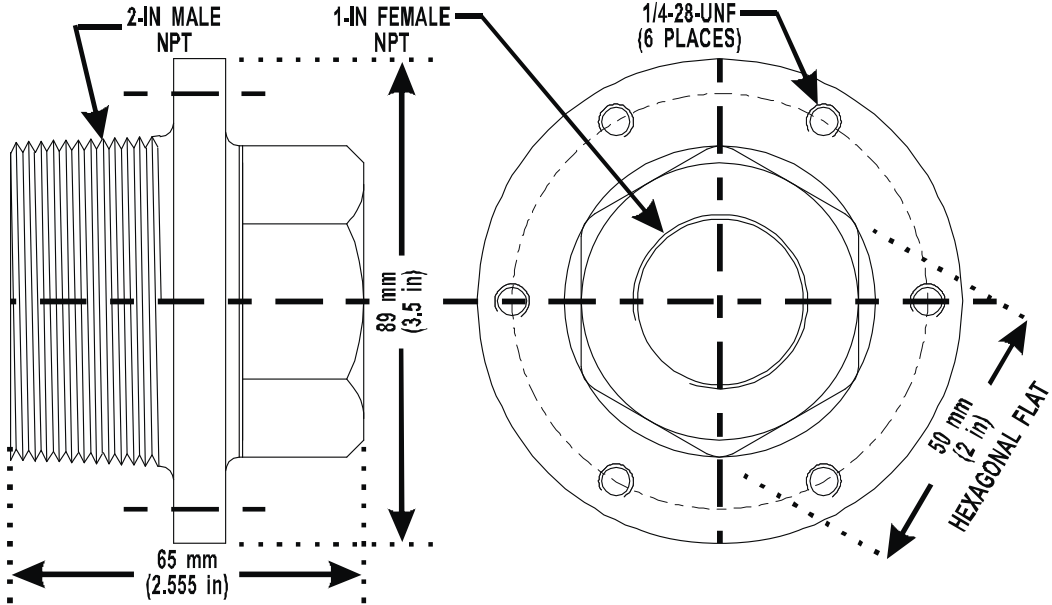

Figure B-5 - 2-In Adaptor

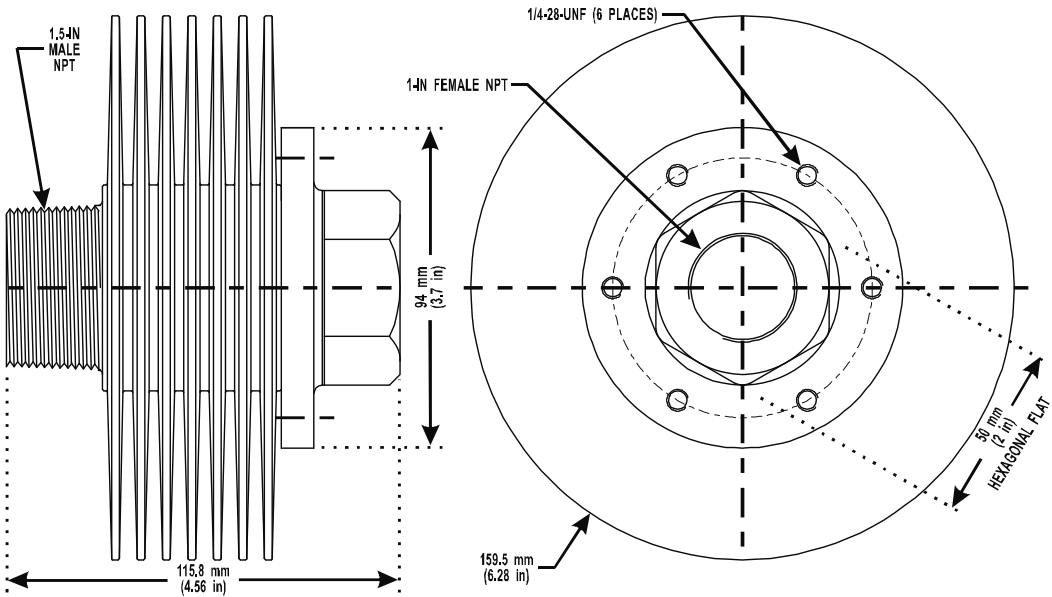

Figure B-6 - Finned High-Temperature Adaptor

B.2 HYDRAN 201Ci-C COMMUNICATIONS CONTROLLER

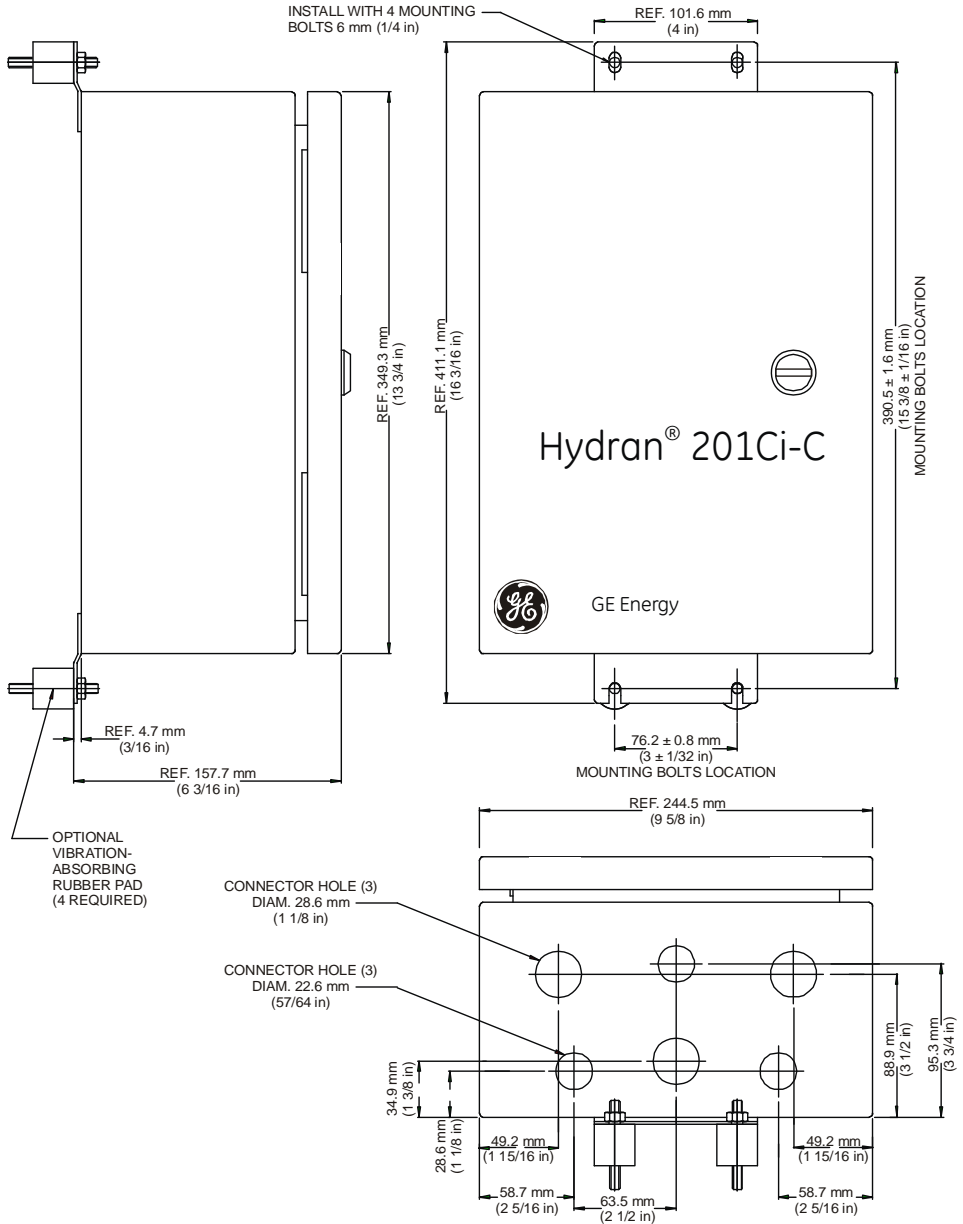

Figure B-7 - Hydran 201Ci-C Dimensions

B.3 HYDRAN 201Ci-1 ONE-CHANNEL CONTROLLER

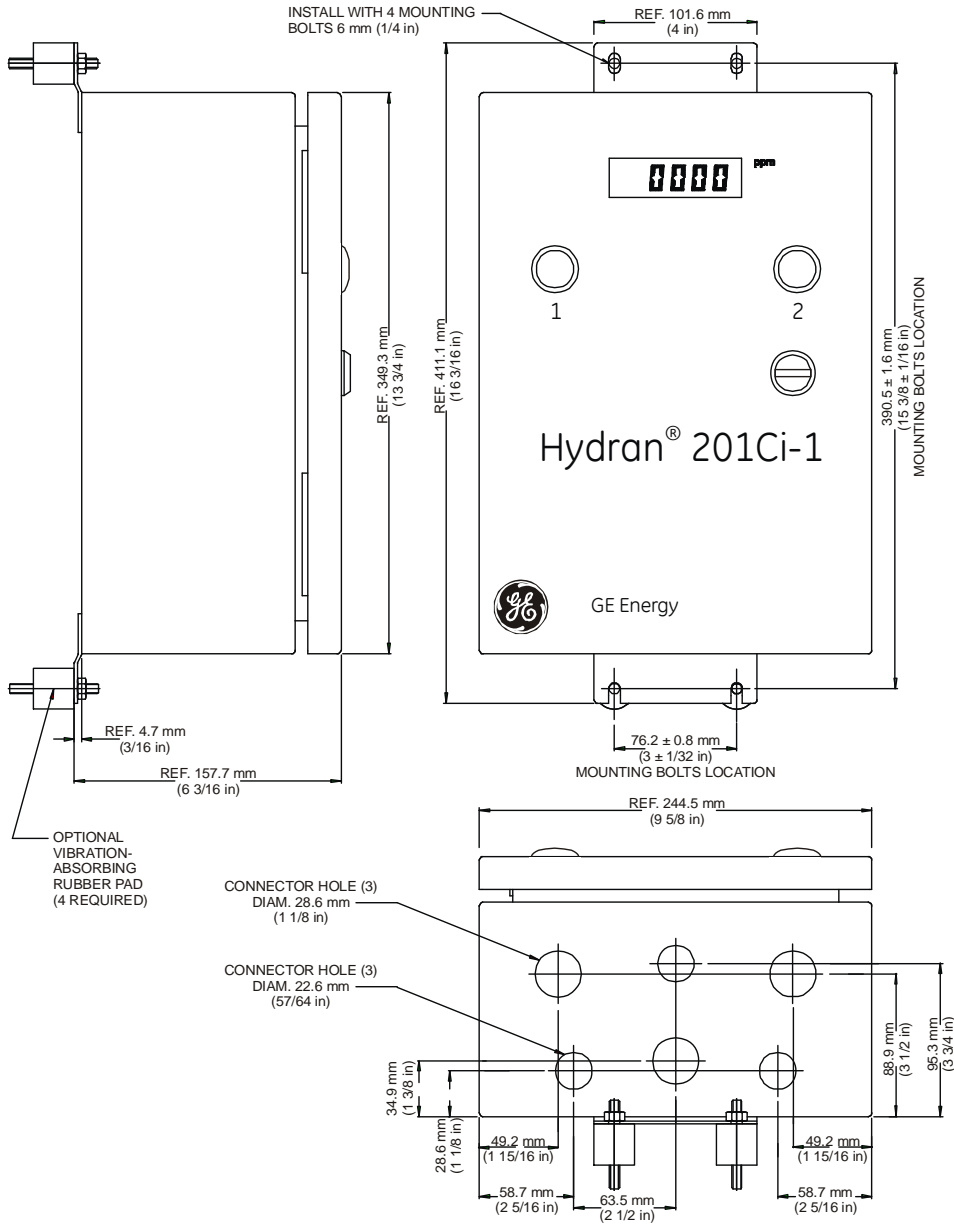
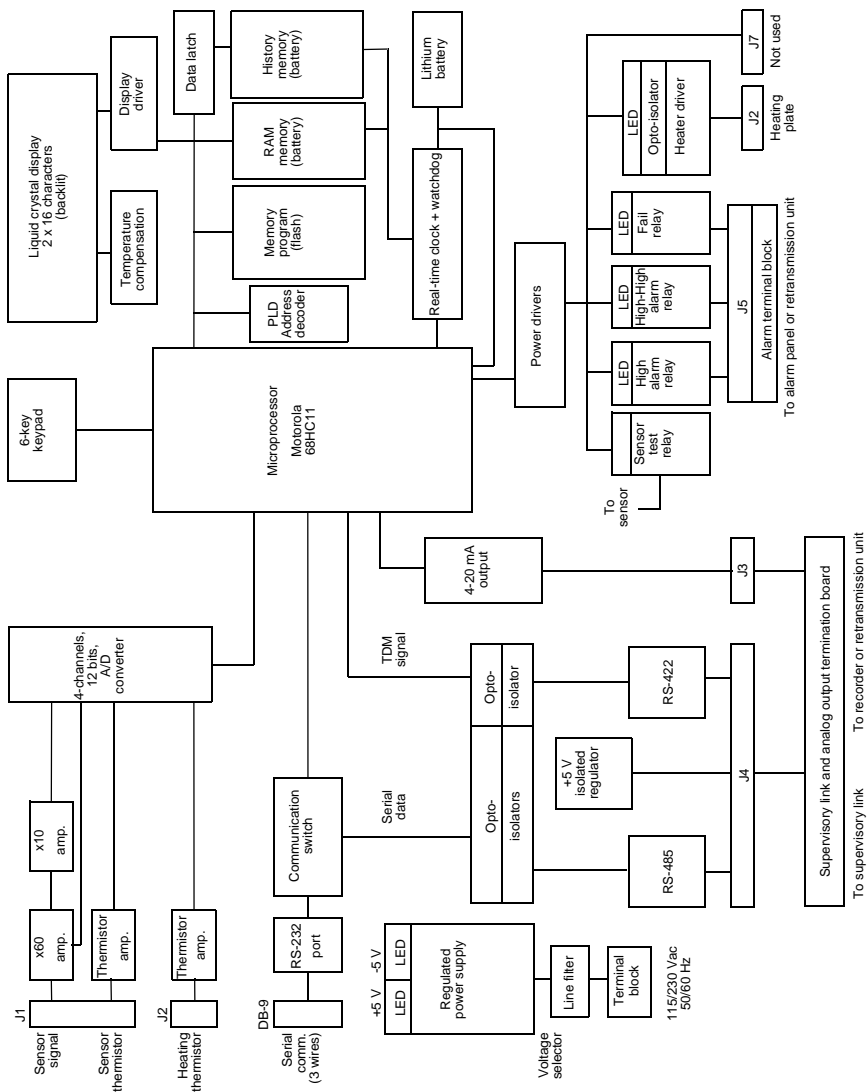

Figure B-8 - Hydran 201Ci-1 Dimensions

Functional Block Diagrams

C.1 HYDRAN 201T7 INTELLIGENT TRANSMITTER



C.2 HYDRAN 201Ci-C COMMUNICATIONS CONTROLLER

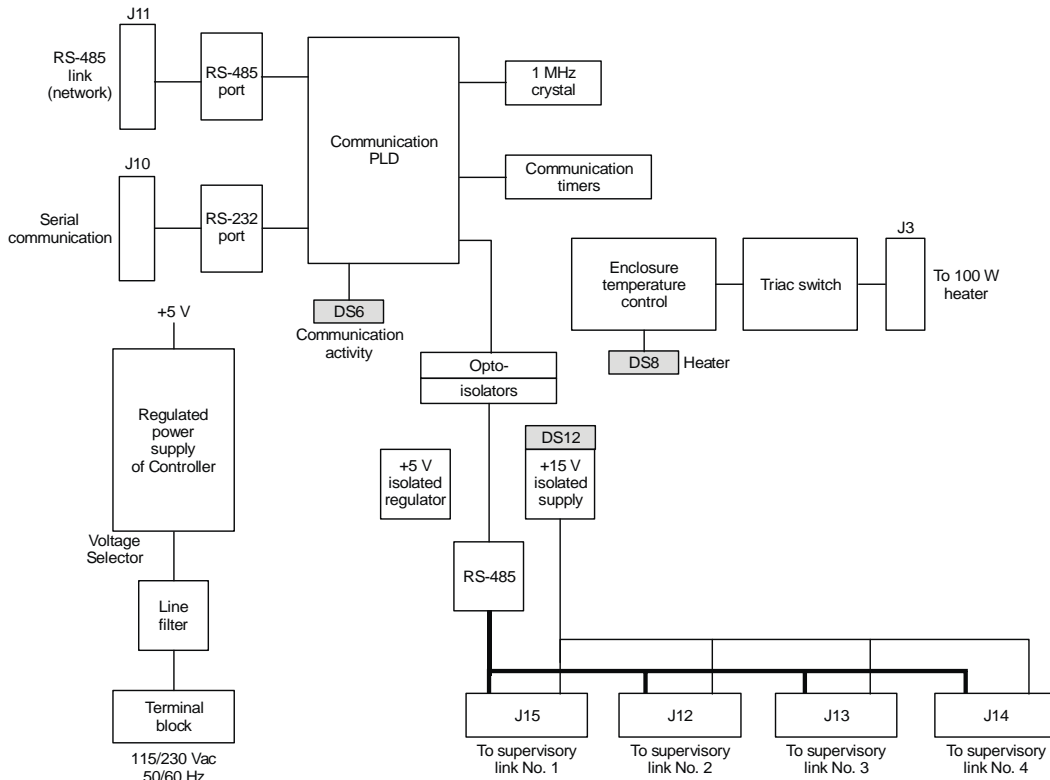

Figure C-2 - Functional Block Diagram for the Hydran 201Ci-C

C.3 HYDRAN 201CI-1 ONE-CHANNEL CONTROLLER

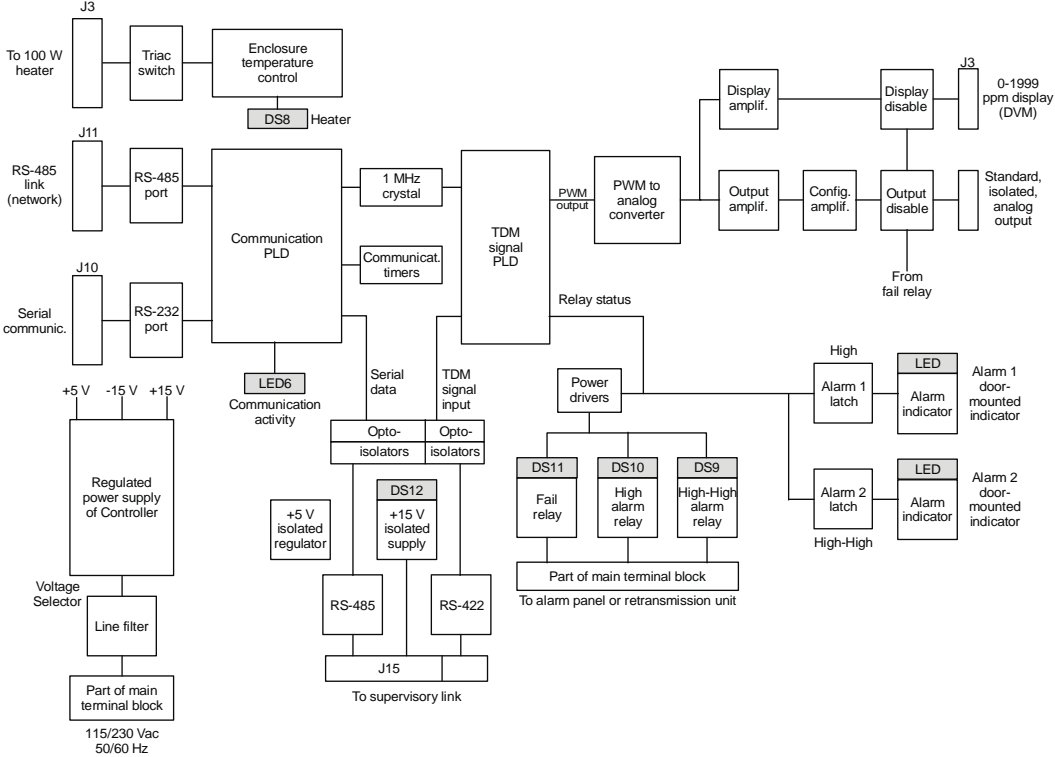

Figure C-3 - Functional Block Diagram for the Hydran 201Ci-C

PAGE LEFT INTENTIONALLY BLANK

Terminal Blocks and Connectors

D.1 HYDRAN 201T7 INTELLIGENT TRANSMITTER

Table D-1 - ac Power Supply: 3-Terminal Block, J3 Connector and Fuse

Terminal	Description ^a	To (Internal)	From (External)	Comments
L1/L	Line or Line1	JP0-1 through line filter	Live side of ac supply	F1 fuse ^b : 5 A, 250 V
L2/N	Neutral or Line2	JP0-2 through line filter	Other side of ac supply	
E/G	Chassis ground	Module chassis and JP0-3	Ground wire of ac supply	Protective ground

a. Wires have a maximum section of 2.5 mm².

b. An isolating, double-pole breaker must be installed in accordance with IEC 947-1 and 947-3.

Table D-2 - Alarm Contacts 9-Terminal Block and J5 Connector

Terminal	Description	From (Internal)	To (External)	Comments
1	Fail NC ^a (no alarm = open)	J5-1	Wired by the user to a SCADA or RTU	Relay rating (resistive): 5 A, 1,250 VA, 240 Vac FCC surge voltage between open contacts: 1,000 V RMS
2	Fail common	J5-2		
3	Fail NO ^b (no alarm = closed)	J5-3		
4	Gas High NC	J5-4		
5	Gas High common	J5-5		
6	Gas High NO	J5-6		
7	Gas High-High NC	J5-7		
8	Gas High-High common	J5-8		
9	Gas High-High NO	J5-9		

a. NC = Normally Closed (contact is closed when the relay is NOT energized)

b. NO = Normally Open (contact is open when the relay is NOT energized)

Appendix D • Terminal Blocks and Connectors

Table D-3 - SW1 Voltage Selector

Voltage Selector ^a	Voltage Range	Comment
115 V	90–132 Vac, 47–63 Hz	430-W maximum heating @ 264 Vac
230 V	180–264 Vac, 47–63 Hz	

a. The voltage selector is factory-selected and configured as per user requirements.

Table D-4 - J2 Heater 6-Pin Connector

Terminals	Description	From (Internal)	To (External)	Comment
J2-1 and J2-5	Heater A	Power board	Heating plate	Heater resistance: 81 Ω (each)
J2-4 and J2-6	Heater B		Thermostat	
J2-2 and J2-3	Thermostat			

Table D-5 - J1 Sensor 4-Pin Connector and J2 Thermistor 2-Pin Connector

Terminal	Description	To (Internal)	From (External)
J1-4	Sensor cell (+)	Cell amplifier	Sensor cable (black)
J1-3	Sensor cell (-)		Sensor cable (brown)
J1-2 J1-1	Sensor thermistor	Sensor thermistor amplifier	Sensor cable (white)
	Cable shield	I/O module chassis	Not connected
J2-1 J2-2	Heater thermistor	Heater thermistor amplifier	Heating plate thermistor
	Cable shield	I/O module chassis	Not connected

Table D-6 - J3 Local Analog Output Connector, J4 Isolated Supervisory Link Connector, and Termination Board

Terminal	Description	From (Internal)	To (External)	Comments
1	TDM pulse, output-	Isolated RS-422 driver, J4-1 and J4-2	Isolated RS-422 receiver	Must be connected to H201Ci-1; not used with H201Ci-C
2	TDM pulse, output+			
3	Serial data, I/O-	Isolated RS-485 transceiver, J4-3 and J4-4	Isolated RS-485 transceiver	Must be connected to any H201Ci Controller
4	Serial data, I/O+			
5	Loop supply, input-	Isolated +5 Vdc regulator input, J4-5 and J4-6	Isolated 15 V link supply output	Isolated power supply built into H201Ci Controller
6	Loop supply, input+			
7	4–20 mA analog current, OUT+	Current loop, J3-2	Wired by the user to a SCADA or RTU	4–20 mA = 0–2,000 ppm (500 Ω maximum)
8	4–20 mA analog current, OUT-	Current loop, J3-3		
Sh 1	Supervisory link cable shield	H201Ti chassis	Supervisory link cable shield	High-frequency grounding
CFG	Analog output configuration	Current loop, J3-4	Active output: not connected Passive output: to the 4–20 mA OUT- terminal 8	See Figure D-1 on page D-4 and Figure D-2 on page D-4

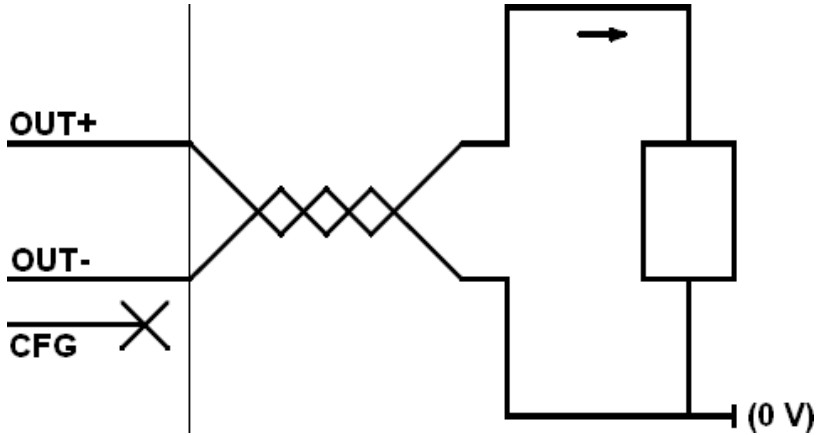

Figure D-1 - Wiring Diagram for Active Current Output

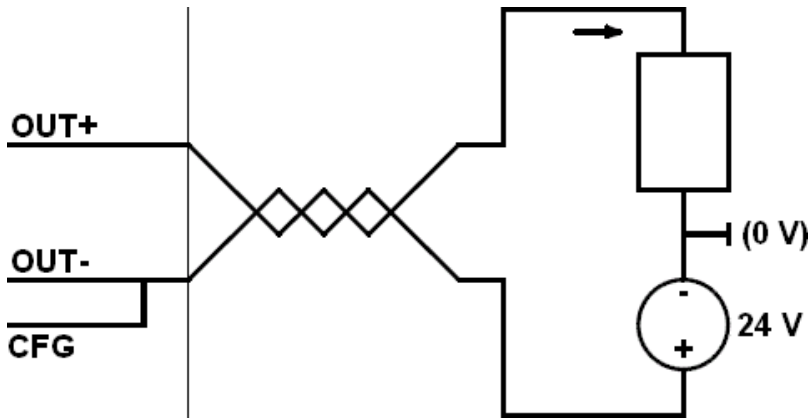

Figure D-2 - Wiring Diagram for Passive Current Output

Table D-7 - DB-9 Male RS-232 Connector (Back of CPU Module)

Terminal	Name	Direction	Comments
2	RxD (receives data)	To H201Ti	The DB-9 connector is wired as in a PC: Cross wires 2 and 3 when connecting to a PC; do not cross wires 2 and 3 when attaching a modem. Only wires 2, 3 and 5 are needed to communicate.
3	TxD (transmits data)	From H201Ti	
5	GND (signal ground)		
1, 4, 6, 9	DCD, DTR, DSR and RI wired together		
7, 8	RTS and CTS wired together		

D.2 HYDRAN 201Ci-C COMMUNICATIONS CONTROLLER

Table D-8 - Main Terminal Block for the Hydran 201Ci-C

Terminal	Description	From (internal)	To (external)	Comments
1	Line or Line1 ^a	J2-1, ac supply connector	Live side of ac supply	F11 fuse: 5 A, 250 V ^b
2	Neutral or Line2 ^a	J2-2, ac supply connector	Other side of ac supply	
3	Chassis ground (earth) ^a			Connect the P/E to the chassis, not to the Main Terminal Block
4	Auxiliary Line or Line1 ^a	J2-1, ac supply connector	Live side of auxiliary ac supply	No fuse installed ^b
5	Auxiliary Neutral or Line2 ^a	J2-2, ac supply connector	Other side of auxiliary ac supply	
6	Auxiliary Chassis ground (earth) ^a	J2-3, ac supply connector	Ground wire of auxiliary ac supply	
7	Not used			
8				
9	Serial data-, I/O unit No. 4	J14-3, supervisory link connector No. 4	Isolated RS-485 transceiver	Must be connected to H201Ti
10	Serial data+, I/O unit No. 4	J14-4, supervisory link connector No. 4		
11	Loop supply-, input	J14-2, supervisory link connector No. 4	Isolated +5 Vdc regulator input	Isolated supply built into H201Ci
12	Loop supply+, input	J14-1, supervisory link connector No. 4		
13	Cable shield	Chassis	Supervisory link cable shield of unit No. 4	Direct ground connection
14	Not used			
15				

Appendix D • Terminal Blocks and Connectors

Terminal	Description	From (internal)	To (external)	Comments
16	Serial data-, I/O unit No. 3	J13-3, supervisory link connector No. 3	Isolated RS-485 transceiver	Must be connected to H201Ti
17	Serial data+, I/O unit No. 3	J13-4, supervisory link connector No. 3		
18	Loop supply-, input	J13-2, supervisory link connector No. 3	Isolated +5 Vdc regulator input	Isolated supply built into H201Ci
19	Loop supply+, input	J13-1, supervisory link connector No. 3		
20	Cable shield	Chassis	Supervisory link cable shield of unit No. 3	Direct ground connection
21	Serial data-, I/O RS-485 LAN	J11-3, RS-485 LAN connector	Isolated RS-485 transceiver	Must be connected to other H201Ci-C or H201Ci-1
22	Serial data+, I/O RS-485 LAN	J11-4, RS-485 LAN connector		
23	RS-485 LAN ground	J11-2, RS-485 LAN connector	Isolated +5 Vdc regulator input	Direct ground connection
24	Cable shield	J11-1, RS-485 LAN connector		
25	Not used			
26				
27				
28				
29	Serial data-, I/O unit No. 2	J12-3, supervisory link connector No. 2	Isolated RS-485 transceiver	Must be connected to H201Ti
30	Serial data+, I/O unit No. 2	J12-4, supervisory link connector No. 2		
31	Loop supply-, input	J12-2, supervisory link connector No. 2	Isolated +5 Vdc regulator input	Isolated supply built into H201Ci
32	Loop supply+, input	J12-1, supervisory link connector No. 2		

Terminal	Description	From (internal)	To (external)	Comments
33	Cable shield	Chassis	Supervisory link cable shield of unit No. 2	Direct ground connection
34	Not used			
35				
36	Serial data-, I/O unit No. 1	J15-3, supervisory link connector No. 1	Isolated RS-485 transceiver	Must be connected to H201Ti
37	Serial data+, I/O unit No. 1	J15-4, supervisory link connector No. 1		
38	Loop supply-, input	J15-2, supervisory link connector No. 1	Isolated +5 Vdc regulator input	Isolated supply built into H201Ci
39	Loop supply+, input	J15-1, supervisory link connector No. 1		
40	Cable shield	Chassis	Supervisory link cable shield of unit No. 1	Direct ground connection

- a. Wires have a maximum section of 2.5 mm².
- b. An isolating, double-pole breaker must be installed in accordance with IEC 947-1 and 947-3 standards.

Table D-9 - SW1 Voltage Selector for the Hydran 201Ci-C

Voltage Selector ^a	Voltage Range	Comment
115 V	90–132 Vac, 47–63 Hz	130-W maximum heating @ 264 Vac
230 V	180–264 Vac, 47–63 Hz	

- a. The voltage selector is factory-selected and configured as per user requirements.

Appendix D • Terminal Blocks and Connectors

Table D-10 - J10 DB-9 Male RS-232 Connector for the Hydran 201Ci-C

Terminal	Name	Direction	Comments
2	RxD (receives data)	To H201Ci-C	The DB-9 connector is wired as in a PC: Cross wires 2 and 3 when connecting to a PC; do not cross wires 2 and 3 when attaching a modem. Only wires 2, 3 and 5 are needed to communicate.
3	TxD (transmits data)	From H201Ci-C	
5	GND (signal ground)		
1, 4, 6, 9	DCD, DTR, DSR and RI wired together		
7, 8	RTS and CTS wired together		

D.3 HYDRAN 201CI-1 ONE-CHANNEL CONTROLLER

Table D-11 - Main Terminal Block for the Hydran 201Ci-1

Terminal	Description	From (internal)	To (external)	Comments
1	Line or Line1 ^a	J2-1, ac supply connector	Live side of ac supply	F11 fuse: 5 A, 250 V ^c
2	Neutral or Line2 ^a	J2-2, ac supply connector	Other side of ac supply	
3	Chassis ground (earth) ^a			Connect the P/E to the chassis, not to the Main Terminal Block
4	Auxiliary Line or Line1 ^a	J2-1, ac supply connector	Live side of auxiliary ac supply	No fuse installed ^b
5	Auxiliary Neutral or Line2 ^a	J2-2, ac supply connector	Other side of auxiliary ac supply	
6	Auxiliary Chassis ground (earth) ^a	J2-3, ac supply connector	Ground wire of auxiliary ac supply	

Terminal	Description	From (internal)	To (external)	Comments
7	Gas High (Alarm 1) NO ^b	J18-6, alarm contacts connector	Wired by the user to a SCADA or RTU	Current rating: 5 A Voltage rating: 300 Vdc 1,250 VA @ 240 Vac
8	Gas High (Alarm 1) Common	J18-5, alarm contacts connector		
9	Gas High (Alarm 1) NC	J18-4, alarm contacts connector		
10	Gas High-High (Alarm 2) NO	J18-9, alarm contacts connector		
11	Gas High-High (Alarm 2) Common	J18-8, alarm contacts connector		
12	Gas High-High (Alarm 2) NC	J18-7, alarm contacts connector		
13	System Fail NO (closed when no alarm)	J18-3, alarm contacts connector		
14	System Fail Common	J18-2, alarm contacts connector		
15	System Fail NC (open when no alarm)	J18-1, alarm contacts connector		
16	Not used			
17	4–20 mA analog current, OUT+	J22-2, analog outputs connector	Wired by the user to a recorder, display or RTU	Active output: See Figure D-1 on page D-4 Passive output: See Figure D-2 on page D-4
18	4–20 mA analog current, OUT-	J22-3, analog outputs connector		
19	Configuration	J22-4, analog outputs connector		
20	Analog output shield	J22-1, analog outputs connector		
21	Serial data-, I/O RS-485 LAN	J11-3, RS-485 LAN connector	Isolated RS-485 transceiver	Must be connected to other H201Ci-C or H201Ci-1
22	Serial data+, I/O RS-485 LAN	J11-4, RS-485 LAN connector		

Appendix D • Terminal Blocks and Connectors

Terminal	Description	From (internal)	To (external)	Comments
23	RS-485 LAN ground	J11-2, RS-485 LAN connector	LAN ground	Direct ground connection
24	Cable shield	J11-1, RS-485 LAN connector	RS-485 LAN cable shield	
25	Not used			
26				
27				
28				
29				
30				
31				
32				
33				
34	TDM pulse-, input	J15-1, supervisory link connector	Isolated RS-422 driver	Must be connected to H201Ti
35	TDM pulse+, input	J15-2, supervisory link connector		
36	Serial data-, I/O	J15-3, supervisory link connector	Isolated RS-485 transceiver	
37	Serial data+, I/O	J15-4, supervisory link connector		
38	Loop supply-, input	J15-5, supervisory link connector	Isolated +5 Vdc regulator input	
39	Loop supply+, input	J15-6, supervisory link connector		
40	Cable shield	Chassis	Supervisory link cable shield	Direct ground connection

- a. Wires have a maximum section of 2.5 mm².
- b. NO = Normally Open; NC = Normally Closed.
- c. An isolating, double-pole breaker must be installed in accordance with IEC 947-1 and 947-3 standards.

Table D-12 - SW1 Voltage Selector for the Hydran 201Ci-1

Voltage Selector ^a	Voltage Range	Comment
115 V	90–132 Vac, 47–63 Hz	130-W maximum heating @ 264 Vac
230 V	180–264 Vac, 47–63 Hz	

a. The voltage selector is factory-selected and configured as per user requirements.

Table D-13 - J10 DB-9 Male RS-232 Connector for the Hydran 201Ci-1

Terminal	Name	Direction	Comments
2	RxD (receives data)	To H201Ci-1	The DB-9 connector is wired as in a PC: Cross wires 2 and 3 when connecting to a PC; do not cross wires 2 and 3 when attaching a modem. Only wires 2, 3 and 5 are needed to communicate.
3	TxD (transmits data)	From H201Ci-1	
5	GND (signal ground)		
1, 4, 6, 9	DCD, DTR, DSR and RI wired together		
7, 8	RTS and CTS wired together		

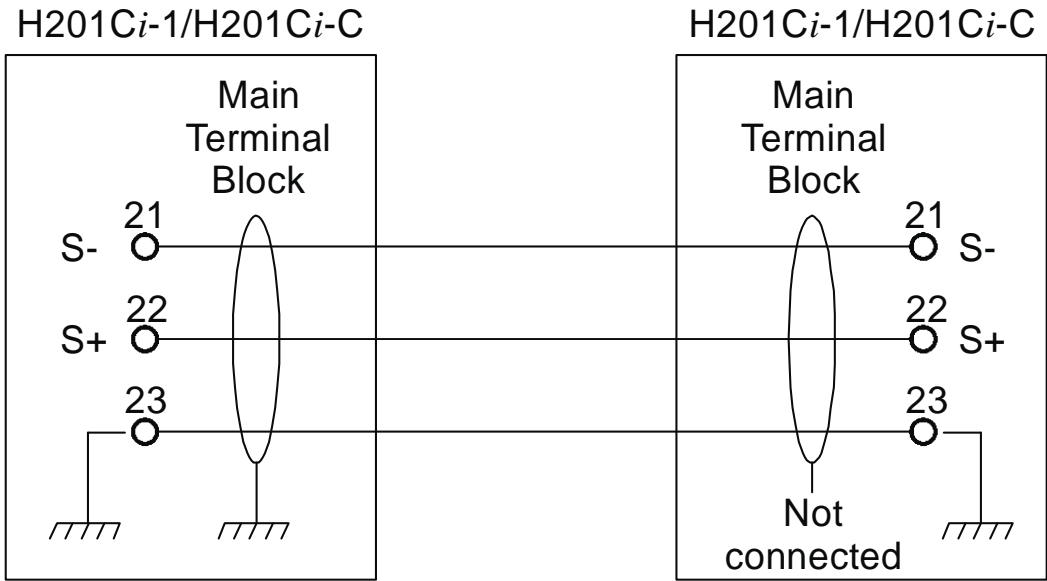

Figure D-3 - Wiring of RS-485 Link Cable Between Two or More H201Ci-C's or H201Ci-1's

Note: The cable shield must be connected to the enclosure ground at only one end.

Hydran 201Ti's History File Messages

This Appendix complements Section 4.5.1 on page 4-12. The messages are sorted in alphabetical order:

Event	Message Description
AnalogMode chg	Modification of the analog output's operation mode
Batt.Alr Ack	Battery voltage fail alarm has been acknowledged
BattAlr L chg	Modification of the Low battery voltage alarm's set point
BattAlr L OFF	Low battery voltage alarm turned off
BattAlr L ON	Low battery voltage alarm turned on
BattAlr LL chg	Modification of the Low-Low battery voltage alarm's set point
BattAlr LL OFF	Low-Low battery voltage alarm turned off
BattAlr LL ON	Low-Low battery voltage alarm turned on
BattDelay chg	Modification of the battery voltage alarm's delay
BaudRate c.	Modification of the transmission rate (bits per second)
CableOpen OFF	Open cable alarm turned off
CableOpen ON	Open cable alarm turned on
CableShort OFF	Short circuit cable alarm turned off
CableShort ON	Short circuit cable alarm turned on
CommMode chg	Modification of the communication mode
Date&Time chg	Modification of the date and/or time
DayAcqRate chg	Modification of the daily trend period
DayAlr Ack	Daily trend alarm has been acknowledged
DayAlr H chg	Modification of the High daily trend alarm's set point
DayAlr H OFF	High daily trend alarm turned off
DayAlr H ON	High daily trend alarm turned on
DayAlr HH chg	Modification of the High-High daily trend alarm's set point
DayAlr HH OFF	High-High daily trend alarm turned off
DayAlr HH ON	High-High daily trend alarm turned on

DayAlr L chg	Modification of the Low daily trend alarm's set point
DayAlr L OFF	Low daily trend alarm turned off
DayAlr L ON	Low daily trend alarm turned on
DayAlr LL chg	Modification of the Low-Low daily trend alarm's set point
DayAlr LL OFF	Low-Low daily trend alarm turned off
DayAlr LL ON	Low-Low daily trend alarm turned on
DayDelay chg	Modification of the daily trend alarm's delay
DefaultChan chg	Modification of the default communication channel
GasAlr Ack	Gas level alarm has been acknowledged
GasAlr H chg	Modification of the gas level High alarm's set point
GasAlr H OFF	Gas level High alarm turned off
GasAlr H ON	Gas level High alarm turned on
GasAlr HH OFF	Gas level High-High alarm turned off
GasAlr HH ON	Gas level High-High alarm turned on
GasAlr HH chg	Modification of the gas level High-High alarm's set point
GasAlr L chg	Modification of the gas level Low alarm's set point
GasAlr L OFF	Gas level Low alarm turned off
GasAlr L ON	Gas level Low alarm turned on
GasAlr LL chg	Modification of the gas level Low-Low alarm's set point
GasAlr LL OFF	Gas level Low-Low alarm turned off
GasAlr LL ON	Gas level Low-Low alarm turned on
GasDelay chg	Modification of a gas level alarms' delay
H201 ID chg	Modification of the H201Ti's identification number
HistoEvent Clr	Historic data file Events has been cleared (erased)
HistoLogRate c	Modification of the logging rate of the Short Term history recordings
Hist LogTime chg	Modification of one of the four logging times of the Long Term history recordings
HistoLong Clr	Historic data file Long Term has been cleared (erased)
HistoRam Bad	RAM memory test of historic data has failed
HistoService Clr	Historic data file Service has been cleared (erased)
HistoShort Clr	Historic data file Short Term has been cleared (erased)
HourAlr Ack	Hourly trend alarm has been acknowledged
HourAlr H chg	Modification of the hourly trend High alarm's set point
HourAlr H OFF	Hourly trend High alarm turned off
HourAlr H ON	Hourly trend High alarm turned on
HourAlr HH chg	Modification of the hourly trend High-High alarm's set point

HourAlr HH OFF	Hourly trend High-High alarm turned off
HourAlr HH ON	Hourly trend High-High alarm turned on
HourAlr L chg	Modification of the hourly trend Low alarm's set point
HourAlr L OFF	Hourly trend Low alarm turned off
HourAlr L ON	Hourly trend Low alarm turned on
HourAlr LL chg	Modification of the hourly trend Low-Low alarm's set point
HourAlr LL OFF	Hourly trend Low-Low alarm turned off
HourAlr LL ON	Hourly trend Low-Low alarm turned on
HourDelay chg	Modification of the hourly trend alarm's delay
HourAcqRate chg	Modification of the hourly trend period
InternalErr 0	Internal error No. 0
InternalErr 1	Internal error No. 1
InternalErr 2	Internal error No. 2
InternalErr 3	Internal error No. 3
InternalErr 4	Internal error No. 4
InternalErr 5	Internal error No. 5
NewSensor	Installation of a new sensor
Period A chg	Modification of the Period A parameter
Period B chg	Modification of the Period B parameter
PowerDown	Power-down of H201Ti
PowerUp	Power-up of H201Ti
PowStat ID chg	Modification of the power station's identification number
ProgRam Bad	RAM memory test of program data has failed
ProgUpgraded	H201Ti's embedded software has been upgraded
RelayMode chg	Modification of a relay's operating mode
ReplaceNow OFF	Replace-sensor-now alarm turned off
ReplaceNow ON	Replace-sensor-now alarm turned on
ReplaceSoon OFF	Replace-sensor-soon alarm turned off
ReplaceSoon ON	Replace-sensor-soon alarm turned on
RTC Bad	Real-time clock has failed
SensTstAlr Ack	Sensor fail alarm has been acknowledged
SetupLost Ack	Setup lost alarm has been acknowledged
SetupLost OFF	Setup lost alarm turned off

Appendix E • Hydran 201Ti's History File Messages

Set-up Lost ON	Setup lost alarm turned on
Soft WatchDog	Reset of H201Ti induced by the software watchdog
Sp Span chg	Modification of the sensor temperature set point's range
STempAlr Ack	Sensor temperature fail alarm has been acknowledged
STempAlr H chg	Modification of the sensor temperature High alarm's set point
STempAlr H ON	Sensor temperature High alarm turned on
STempAlr HH chg	Modification of the sensor temperature High-High alarm's set point
STempAlr HH ON	Sensor temperature High-High alarm turned on
STempAlr L chg	Modification of the sensor temperature Low alarm's set point
STempAlr L ON	Sensor temperature Low alarm turned on
STempAlr LL chg	Modification of the sensor temperature Low-Low alarm's set point
STempAlr LL ON	Sensor temperature Low-Low alarm turned on
STempDelay chg	Modification of the sensor temperature alarm's delay
STemp H OFF	Sensor temperature High alarm turned off
STemp HH OFF	Sensor temperature High-High alarm turned off
STemp L OFF	Sensor temperature Low alarm turned off
STemp LL OFF	Sensor temperature Low-Low alarm turned off
STempSetP chg	Modification of the sensor temperature set point
SystemCalib	Calibration of H201Ti
TDM Mode chg	Modification of the TDM signal's operating mode
Unit in Service	H201Ti back in service after the battery was disconnected
Watchdog	Reset of H201Ti induced by the hardware watchdog

Default Values of the Parameters

Table F-1 on page F-1 presents the default values of the adjustable parameters after the battery has been disconnected or after the Hydran 201Ti's embedded software has been upgraded.

Table F-1 - Default Values of the Parameters

Category	Parameter	Unit	Value	Status
Gas level	Period B	Hours	24	
	Low-Low alarm	ppm	5	Disabled
	Low alarm	ppm	15	Disabled
	High alarm	ppm	250	Enabled
	High-High alarm	ppm	500	Enabled
	Alarms delay	Minutes	10	
Hourly trend	Trend period	Hours	24	
	Low-Low alarm	ppm/period	-20	Disabled
	Low alarm	ppm/period	-10	Disabled
	High alarm	ppm/period	10	Enabled
	High-High alarm	ppm/period	20	Enabled
	Alarms delay	% of period	33	
Daily trend	Trend period	Days	30	
	Low-Low alarm	ppm/period	-50	Disabled
	Low alarm	ppm/period	-25	Disabled
	High alarm	ppm/period	25	Enabled
	High-High alarm	ppm/period	50	Enabled
	Alarms delay	% of period	33	

Appendix F • Default Values of the Parameters

Category	Parameter	Unit	Value	Status
Temperature	Desired temperature	°C	35	
	Modulation amplitude	°C	0.0	
	Period A	Minutes	60	
	Low-Low alarm	°C	5	Enabled
	Low alarm	°C	5	Enabled
	High alarm	°C	65	Enabled
	High-High alarm	°C	75	Enabled
	Alarms delay	Minutes	30	
Battery	Low-Low alarm	Volt	2.45	Enabled
	Low alarm	Volt	2.75	Enabled
	Alarms delay	Hours	50	
Historical data acquisition	Short term log rate	Minutes	15	
	Long term log time #1		00:00	
	Long term log time #2		06:00	Enabled
	Long term log time #3		12:00	Enabled
	Long term log time #4		18:00	Enabled
Communications	CommChannel		Supervisory Link	
	DefaultChannel		Supervisory Link	
	CommMode		Call OnAlarm	
	BaudRate		9600	
	H201Ti ID			
	PowerStat. ID			

Category	Parameter	Unit	Value	Status
Relays/Analog	Gas High		Normal	
	Gas High-High		Normal	
	SysOK		Normal	
	Analog output		Normal	
	TDM pulse output		Normal	
Fault triggers	Low-Low gas level			Disabled
	Low gas level			Disabled
	Low-Low hourly trend			Disabled
	Low hourly trend			Disabled
	Low-Low daily trend			Disabled
	Low daily trend			Disabled
	Low-Low sensor temperature			Enabled
	Low sensor temperature			Enabled
	High sensor temperature			Enabled
	High-High sensor temperature			Enabled
	Low-Low battery			Enabled
	Low battery			Enabled
	CableShort			Enabled
	Replace SensSoon			Enabled
	Replace SensNOW			Enabled
CableOpen			Enabled	

PAGE LEFT INTENTIONALLY BLANK

Unit Conversions

In a current loop, any length of cable and number of devices can be connected in series provided that the following conditions are met:

- All devices have floating differential inputs (*both* leads of signal input are ungrounded).
- The total loop resistance does not exceed 500 Ω .

G.1 CONVERTING CURRENT TO VOLTAGE

Recording devices with voltage inputs can be converted to current inputs by shunting their input terminals with an appropriate resistor. The resistor value is calculated as follows:

$$\text{Resistor } (\Omega) = 50 \times \text{input voltage range (in volts) of recording device}$$

Example: A chart recorder with an input range of 1 V uses a 50- Ω (1 %, 1 W) resistor across the recorder input.

G.2 CONVERTING PPM TO MA (OR VICE VERSA)

To convert mA (milliamperes) into ppm (or vice versa), use the following formulas:

$$\text{ppm} = 125 \times (\text{mA} - 4); \text{ or } \text{mA} = 4 + (\text{ppm} \div 125)$$

Example: For a 4.8-mA current, the level of gases in oil is 100 ppm. Likewise, if the display reads 250 ppm, then the current value is 6.0 mA.

PAGE LEFT INTENTIONALLY BLANK

Extracting an Oil Sample

Proceed as follows to sample the oil from the transformer (see Figure H-1 on page H-2):

1. Remove the Hydran 201Ti's aluminum cover.
2. Open the Luer stopcock valve of the glass syringe and ensure the syringe is free of air.
3. Insert and adjust the tip of the syringe valve into the sensor's sampling port.
4. Using the 5/32-in Allen key, slowly open the sensor's bleed screw.
5. Generally, the oil pressure by itself should fill the syringe. If not, slowly pull the syringe's plunger.
6. When the syringe contains enough oil (35 mL for a DGA), shut the bleed screw.
7. Close the stopcock valve of the syringe.
8. Withdraw the syringe.
9. Empty the syringe; make sure to purge all air bubbles from the syringe. This first extraction allows to wet the inner walls of the syringe with liquid to assure better accuracy of sampling.
10. Repeat steps 3 to 8 to extract the oil sample.
11. Purge all air bubbles from the syringe.
12. Put back the aluminum cover.
13. Fill an identification card for this sample. Indicate the gas level and temperature readings performed by the H201Ti at the time of sampling.

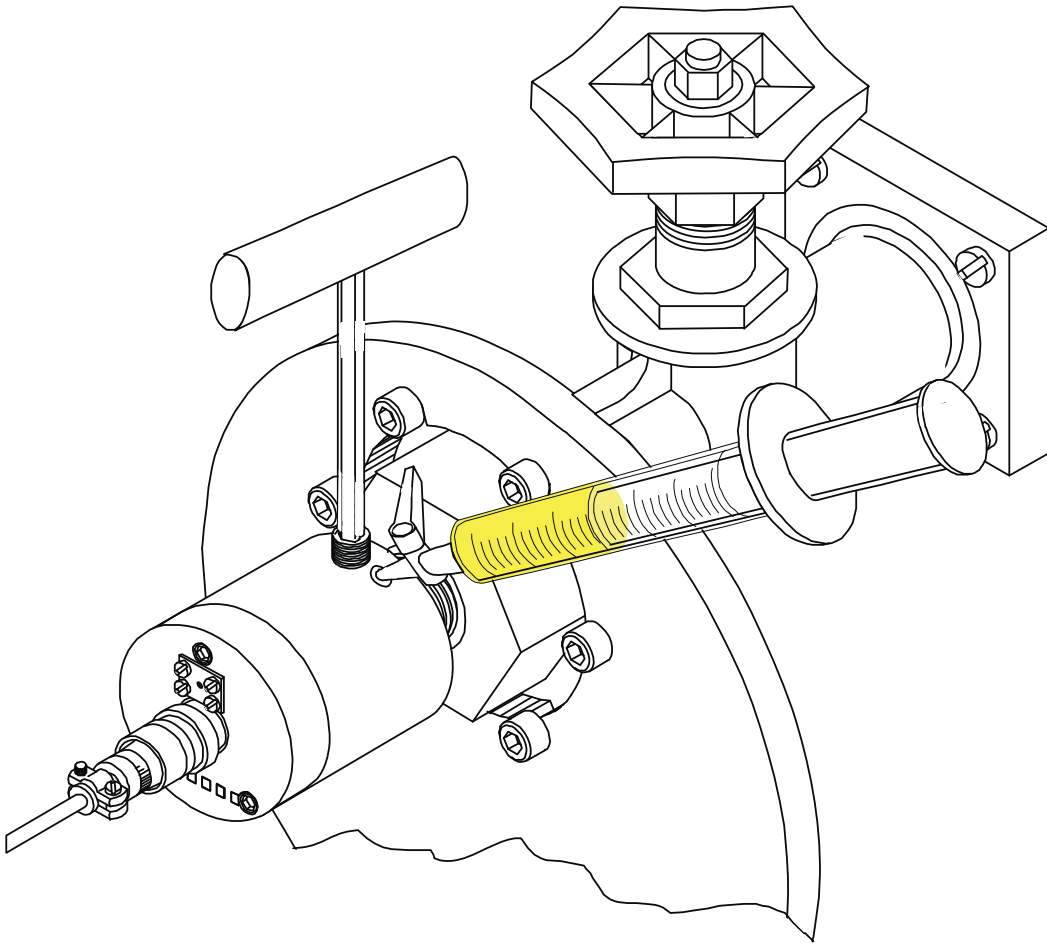

Figure H-1 - Extracting an Oil Sample From the Hydran 201 Sensor's Sampling Port Using a Glass Syringe and a 5/32-In Allen Key

A: Ampere

ac: Alternating Current

ACK: ACKnowledge

A/D: Analog-to-Digital converter. An electronic device, often an integrated circuit, that converts the value of a continuous electrical quantity, such as voltage or current, into its digital equivalent; all possible values of the quantity are then represented by a finite set of discrete values. All digital instruments use an A/D converter to convert the input signal into digital information.

Adaptor (brass): Device used to mount a Hydran 201Ti (specifically its Hydran 201 sensor) onto a valve of the electrical equipment to monitor (typically a transformer)

Alarm: Operating condition occurring when a data point value exceeds the parameter's alarm set-point

Alarm Contact: Terminal used as interface between the alarm relays of the Hydran 201i System and any SCADA system (alarm panel, etc.)

Analog Output: Analog signal that is proportional to the gas level reading performed by the Hydran 201Ti

Analog Signal: Electronic signal that can represent an infinite range of numbers (as opposed to digital signal)

Analysis: Algorithm applied to data points for the purpose of calculating features that are then applied to rules

ANSI: American National Standards Institute, a standards-setting, non-governmental organization that develops and publishes standards for voluntary use in the United States

ASTM: American Society for Testing and Materials (United States)

AWG: American Wire Gauge (United States)

bps: Bit Per Second

CD-ROM: Compact Disc - Read-Only Memory

CE: European Conformity

CH₄: Methane

C₂H₂: Acetylene

C₂H₄: Ethylene

C₂H₆: Ethane

Channel: Path along which data passes in the form of electrical signals

CO: Carbon monOxide

CO₂: Carbon diOxide

COM: Serial COMmunication port on a PC

Combustible Gas: Fault gas in the dielectric oil of a transformer

CPU: Central Processing Unit

CSA: Canadian Standards Association

D/A: Digital-to-Analog converter. An electronic device, often an integrated circuit, that converts a finite set of discrete values into an equivalent electrical quantity, such as voltage or current. Many analog instruments use a D/A converter to convert the digital reading information into an analog signal for analog output.

Daily Trend: Variation of gas level during an adjustable period of time calculated in days

Daisy Chain: Parallel connection from one Hydran 201Ci Controller to another using an RS-485 link cable

dc: Direct Current

DCS: Distributed Control System

DGA: Dissolved Gas Analysis

Diagnostic: Identification of specific malfunctions of an electrical apparatus

Digital Output: Output that provides a digital signal derived from the digital information within the instrument

Digital Signal: Electronic signal that can only represent discrete numbers (as opposed to analog signal)

DIN: Deutsches Institut für Normung, a german standards institute

DVM: Digital VoltMeter

EC: Electronic Controller, the Intel Pentium* PC responsible for data acquisition, transfer, storage, interpretation and communications

EEC: European Economic Community

E/G: Earth/Ground

Embedded Software: Small program that runs inside the Hydran 201Ti. It manages the dynamic oil sampling system, monitors alarm conditions, triggers alarms, displays the gas level readings and other values, etc. It also allows a user to set and modify the value of every operational parameter.

EMI: ElectroMagnetic Interference

End User: Commercial client for General Electric Canada

Error: Deviation (difference or ratio) of a measurement from its true value

ESC: ESCape key on the Hydran 201Ti's keypad

ESD: ElectroStatic Discharge

Extended Menu: Menu of the Hydran 201Ti's embedded software that gives access to all operation parameters and commands (including those of the Main Menu)

Fault: Indication (other than diagnostics) issued by the hardware or software that an anomaly exists in the Hydran 201Ti

FCC: Federal Communications Commission, the United States government agency responsible for ensuring that phone lines are being used correctly and that radio interference is at acceptable levels

Feedback: A means of providing indication of operation either by measured values or contact status (on/off)

FIFO: First In, First Out. The first data into a memory buffer is the first data out of the buffer.

Gas Level: Composite value of four dissolved gases in transformer oil, measured by the Hydran 201 sensor

GE: General Electric

GND: GrouND (earth), a common reference point in an electric or electronic circuit

GUI: Graphical User Interface, the graphical layout designed to enable user interaction with the Hydran 201Ti. It enables information to be passed between a user and hardware or software components of a computer system via graphical symbols (icons, buttons and menus) located on a screen, accessed using a mouse, keyboard, keypad, etc.

H or Hi: High alarm

H₂: Hydrogen

Hardware: The physical parts of a computer-controlled system, such as circuit boards, chassis, peripheral devices, cables, etc.

HH or Hi-Hi: High-High alarm

History File: Either one of four distinct groups of data (Short Term, Long Term, Events and Service) that are recorded automatically and/or periodically and stored in the Hydran 201Ti's memory

HMI: Human/Machine Interface

Host Computer: IBM PC (or compatible) connected remotely to a Hydran 201i System and running the Hydran Host software

Hourly Trend: Variation of gas level during an adjustable period of time calculated in hours

Hydran 201Ci: Any of the controllers from the Hydran family of products: Hydran 201Ci-1 or Hydran 201Ci-C. Abbreviated to H201Ci.

Hydran 201Ci-1: One-channel controller designed to supervise one Hydran 201Ti and link it to a host computer running the Hydran Host software. This configuration is referred to as Hydran 201R Model *i*. Abbreviated to H201Ci-1.

Hydran 201Ci-C: Communications controller designed to supervise up to four Hydran 201Ti's. The Hydran 201Ci-C does not have a numerical display, analog outputs or alarm contacts; it is meant only as an interface between the Hydran 201Ti's and the host computer running the Hydran Host software. Abbreviated to H201Ci-C.

Hydran 201i System: Continuous, on-line, combustible gas-in-oil monitor, taking the form of either a Hydran 201Ti used alone or the combination of at least one Hydran 201Ti and a Hydran 201Ci Controller

Hydran 201R Model *i*: Specific configuration of Hydran 201i System, which consists of one Hydran 201Ti linked to a Hydran 201Ci-1. This combination has been designed to replace or complete an existing installation of Hydran 201R (previous generation of transformer incipient fault monitor).

Hydran 201 Sensor: Electrochemical gas detector used in the Hydran 201Ti to detect and measure a composite value of four dissolved gases in transformer oil

Hydran 201Ti: Intelligent transmitter, an apparatus that uses an electrochemical gas detector to detect and measure a composite value of four dissolved gases in transformer oil. Abbreviated to H201Ti.

Hydran Host: Microsoft Windows software that communicates, through an RS-232 serial communication link or a modem, with one or several Hydran 201Ti's using the host computer. It allows a user to set operational parameters, survey alarm status, etc.

Hz: Hertz, a unit of frequency equal to a cycle per second

ID: Identification

IEC: International Electrotechnical Commission

IED: Intelligent Electronic Device

IEEE: Institute of Electrical and Electronics Engineers (United States)

in: INch

I/O: Input/Output, two of the three activities (input, processing and output) characterizing a computer. Refers to the complementary tasks of gathering data for the microprocessor to work with and making the results available to the user through communication channels such as the display, a disk drive or a printer.

Isolated Output: Output signal where a common reference is not connected to either input terminal

kVA: KiloVolt-Ampere

L or Lo: Low alarm

Lab Data: Manually-entered gas sample data obtained from laboratory results

LAN: Local Area Network, a group of computers and other devices dispersed over a relatively-limited area and connected by a communications link enabling any device to interact and share with any other device or resource on the network. Usually, there is one computer that controls all peripherals (such as printers and a hard disk drive). The other computers are linked to the controlling computer, which lets the other computers take turns using the peripherals.

LCD: Liquid Crystal Display, a type of flat-panel display commonly used on laptops or PC's

LED: Light-Emitting Diode

LL or Lo-Lo: Low-Low alarm

Local Network: Daisy chain of Hydran 201Ci Controllers connected together using an RS-485 link in order to monitor Hydran 201Ti's locally or remotely (via modem) using the Hydran Host software

Local Site: User location where the data of the remote site is being analyzed

mA: MilliAmpere

mAdc: MilliAmpere Direct Current

Main Menu: Menu of the Hydran 201Ti's embedded software that gives access to the most frequently used operation parameters and commands

Menu: Group of parameters and values accessed through a hierarchical, treelike structure

MHz: MegaHertz, a unit of frequency equal to one million cycles per second

Modem: MOdulator/DEModulator, a communication device connecting data terminal equipment to an analog or digital line. A modem transforms digital signals into an analog signal suitable for transmission over telephone lines. This is the heart of computer telecommunications. The main factor that differentiates modems is their speed, measured in bps or bauds.

MOV: Metal Oxide Varistor

MVA: MegaVolt-Ampere

mV/A: MilliVolt per Ampere

N₂: Nitrogen

NC: Normally Closed

NEMA: National Electrical Manufacturers Association enclosure standards, a protection classification set by the NEMA. Type NEMA 4X enclosures are weatherproof and corrosionproof. They are primarily intended for indoor or outdoor use to provide a degree of

protection against corrosion, windblown dust and rain, splashing water, hose directed water, and damage from external ice formation.

Network: Group of interrelated or interconnected nodes

NO: Normally Open

NPT: National Pipe Thread (United States)

Null Modem: A special connection between two computers that makes them think they are hooked up to a modem, so that the two computers can communicate with each other

O₂: Oxygen

Oil Sample: Small quantity of oil, representative of the oil contained in the transformer

PC: Personal Computer, a computer typically based on an Intel microprocessor and capable of receiving network cards, modems, data acquisition boards, etc.

PCB: Printed Circuit Board

PDF: Portable Document Format

PLC: Programmable Logic Controller

P/N: Part Number

POT: POTentiometer

ppm: Part Per Million, representing the concentration of a gas in transformer oil

PVC: PolyVinyl Chloride, a plastic used for cable insulation

PWM: Pulse Width Modulation

RAM: Random Access Memory, a semiconductor-based memory that can be read and written by the microprocessor or other digital hardware devices

Range: A continuous band of signal values that can be measured or sourced. In bipolar instruments, the range includes positive and negative values.

Real-Time: Pertaining to a system or operating mode under which computation is performed during the actual time when an external process occurs, instead of being accumulated and processed at a later time. The computation results can therefore be used to control, monitor, or respond in a timely manner to the external process.

Remote: A connection using modems between a Hydran 201*i* System and a host computer through a public or private telephone system

Remote Site: Location of the Hydran 201*Ti*

Repeatability: The ability of an instrument to measure the same input to the same value over a short period of time and over a narrow temperature range

Response Time: For a measuring instrument, designates the time between the application of a step input signal and the indication of its magnitude within a rated accuracy. For a sourcing instrument, designates the time between a programmed change and the availability of the value at its output terminals.

RFI: Radio-Frequency Interference

RMS: Root Mean Square

ROM: Read-Only Memory

RS-232: Specific type of port on the back of some computers, or peripherals such as modems. It has 9 or 25 pins.

RS-232 Serial Communication Link: Cable that connects a Hydran 201*i* System to a host computer

RS-485 Network Link: Cable that connects Hydran 201*Ci* Controllers together to form a network

RTC: Real-Time Clock

RTD: Resistance Temperature Detector

RTU: Remote Terminal Unit

RTV: Room Temperature Vulcanization

SCADA: Supervisory Control And Data Acquisition, identifying the numerous devices (control panel, alarm panel, retransmission unit, display, terminal, data recorder, external detection device, etc.) on which can be connected the components of the Hydran 201i System

SH: Cable SHield

S/N: Serial Number

SP: Set Point

SPDT: Single Pole Double Throw

SQL: Structured Query Language

SSR: Solid-State Relay

Submenu: A branch of the treelike structure of a menu

Supervisory Link: Cable connecting a Hydran 201Ti to a Hydran 201Ci Controller

TB: Terminal Block

TDM: Time Division Multiplexing, a method of coding and transmitting information

Teflon: polyTEtraFLuOrethyleNe

Termination board: Terminal block used to connect the supervisory link

TM: TradeMark

Transformer Oil: Highly-refined, mineral oil used as a dielectric and heat transfer fluid in transformers

USB: Universal Serial Bus

User: Person operating the Hydran 201i System

User-Friendly: An interface designed to simplify the use of an application

User Interface: The means (display, keypad, push-buttons, etc.) used to achieve communication between the user and a Hydran 201*i* System

μV: Microvolt

V: Volt

VA: Volt-Ampere

Vac: Volt Alternating Current

Vdc: Volt Direct Current

VDE: Verein Deutscher Elektrotechniker, a german standards institute

V-I: Voltage to current

Vibration-Absorbing Rubber Pad: Device used to protect a Hydran 201*Ci* Controller against vibrations

V RMS: Volt Root Mean Square

W: Watt

WAN: Wide Area Network, a communication network using telephone lines or other telecommunication devices to link computers in geographically-separated areas

Watchdog: Process used periodically to test if a computerized system is operating properly

% w/w: Percentage Weight by Weight

PAGE LEFT INTENTIONALLY BLANK

GE Energy Services
Digital Energy
179 Brunswick Blvd.
Pointe-Claire QC H9R 5N2
Canada

T +1 514 694 3637
F +1 514 694 9245
transformermonitoring@ge.com
www.ge.com/energy

GE Energy Services
Digital Energy
Customer Service Center
(24 hours a day, 365 days a year):
T 800 361 3652 (United States and Canada)
T +1 403 214 4600 (worldwide)
ge4service@ge.com



imagination at work



17997